

# LUBRICATION AND MAINTENANCE

## CONTENTS

	page		page
CHASSIS AND BODY .....	19	ENGINE .....	8
DRIVETRAIN .....	15	GENERAL INFORMATION .....	1

## GENERAL INFORMATION

### INDEX

	page		page
Classification of Lubricants .....	1	Parts and Lubricant Recommendations .....	1
Fuel Usage .....	1	Parts Requiring No Lubrication .....	2
Hoisting Recommendations .....	5	Severe Service .....	1
Introduction .....	1	Towing Recommendations .....	6
Jump Starting Procedure .....	2		

### INTRODUCTION

Chrysler Corporation has compiled recommended lubrication and maintenance schedules and procedures to help reduce premature wear or failure over a broad range of operating conditions. When selecting the proper maintenance schedule, the climate and operating conditions must be considered. A vehicle subjected to severe usage requires service more frequently than a vehicle used for general transportation.

### PARTS AND LUBRICANT RECOMMENDATIONS

When service is required, Chrysler Corporation recommends that only Mopar® brand parts, lubricants and chemicals be used. Mopar® provides the best engineered products for servicing Chrysler Corporation vehicles.

### SEVERE SERVICE

If a vehicle is operated under any of the following conditions, it is considered severe service.

- Extremely dusty areas.
- 50% or more of vehicle operation in 32°C (90°F) or higher temperatures.
- Prolonged idling (such as, vehicle operation in stop and go traffic).
- Frequent short running periods. Not allowing engine to warm to operating temperatures.
- Police or taxi usage.

### FUEL USAGE

All Chrysler Corporation engines require the use of unleaded fuel to reduce exhaust emissions. See Engine section of this group for Fuel Recommendations.

### CLASSIFICATION OF LUBRICANTS

Only lubricants that are endorsed by the following organization should be used to service a Chrysler Corporation vehicle.

- Society of Automotive Engineers (SAE)
- American Petroleum Institute (API)
- National Lubricating Grease Institute (NLGI)

### ENGINE OIL

#### SAE GRADE RATING INDICATES ENGINE OIL VISCOSITY

- SAE 30 = single grade engine oil.
- SAE 5W-30 = multiple grade engine oil.

#### API QUALITY CLASSIFICATION.

- SG service engine oil is a high quality crankcase lubricant designed for use in all naturally aspirated engines.
- SG/CD service engine oil is a high quality crankcase lubricant designed for use in most naturally aspirated and turbocharged gasoline or diesel engines.

### GEAR LUBRICANTS

SAE ratings also apply to multiple grade gear lubricants. In addition, API classification defines the lubricants usage.

### LUBRICANTS AND GREASES

Lubricating grease is rated for quality and usage by the NLGI. All approved products have the NLGI symbol on the label.

At the bottom NLGI symbol is the usage and quality identification letters. Wheel bearing lubricant is identified by the letter "G". Chassis lubricant is identified by the letter "L". The letter following the usage letter indicates the quality of the lubricant. The following symbols indicate the highest quality.

#### NLGI SYMBOL

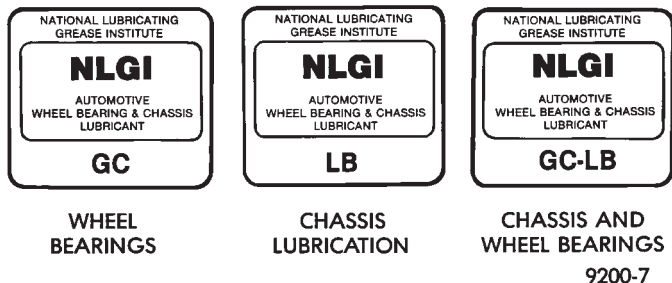

### PARTS REQUIRING NO LUBRICATION

Many components on a Chrysler Corporation vehicle require no periodic maintenance. Some components are sealed and permanently lubricated. Rubber bushings can deteriorate or limit damping ability if lubricated. The following list of components require no lubrication:

- Air Pump
- Alternator Bushings
- Drive Belts
- Drive Belt Idler/Tensioner Pulley
- Front Wheel Bearings
- Rubber Bushings
- Starter Bearings/Bushings
- Suspension Strut Bearings
- Throttle Control Cable
- Throttle Linkage
- Water Pump Bearings

### JUMP STARTING PROCEDURE

**WARNING: REVIEW ALL SAFETY PRECAUTIONS AND WARNINGS IN GROUP 8A, BATTERY/STARTING/CHARGING SYSTEMS DIAGNOSTICS.**

**DO NOT JUMP START A FROZEN BATTERY, PERSONAL INJURY CAN RESULT.**

**DO NOT JUMP START WHEN BATTERY INDICATOR DOT IS YELLOW OR BRIGHT COLOR.**

**DO NOT ALLOW JUMPER CABLE CLAMPS TO TOUCH EACH OTHER WHEN CONNECTED TO A BOOSTER SOURCE.**

**DO NOT USE OPEN FLAME NEAR BATTERY.**

**REMOVE METALLIC JEWELRY WORN ON HANDS OR WRISTS TO AVOID INJURY BY ACCIDENTAL ARCHING OF BATTERY CURRENT.**

**WARNING: WHEN USING A HIGH OUTPUT BOOSTING DEVICE, DO NOT ALLOW DISABLED VEHICLE'S BATTERY TO EXCEED 16 VOLTS. PERSONAL INJURY OR DAMAGE TO ELECTRICAL SYSTEM CAN RESULT.**

**CAUTION: When using another vehicle as a booster, do not allow vehicles to touch. Electrical systems can be damaged on either vehicle.**

#### TO JUMP START A DISABLED VEHICLE:

(1) Raise hood on disabled vehicle and visually inspect engine compartment for:

- Battery cable clamp condition, clean if necessary.
- Frozen battery.
- Yellow or bright color test indicator, if equipped.
- Low battery fluid level.
- Alternator drive belt condition and tension.
- Fuel fumes or leakage, correct if necessary.

**CAUTION: If the cause of starting problem on disabled vehicle is severe, damage to booster vehicle charging system can result.**

(2) When using another vehicle as a booster source, turn off all accessories, place gear selector in park or neutral, set park brake or equivalent and operate engine at 1200 rpm.

(3) On disabled vehicle, place gear selector in park or neutral and set park brake or equivalent. Turn OFF all accessories (Keyless Entry and Ultralight systems must be turned OFF manually).

(4) Connect jumper cables to booster battery. RED clamp to positive terminal (+). BLACK clamp to negative terminal (-). DO NOT allow clamps at opposite end of cables to touch, electrical arc will result (Fig. 1). Review all warnings in this procedure.

(5) On disabled vehicle, connect RED jumper cable clamp to positive (+) terminal. Connect BLACK jumper cable clamp to engine ground as close to the ground cable attaching point as possible (Fig. 1).

LUBRICATION AND MAINTENANCE SCHEDULES

**SCHEDULED MAINTENANCE FOR EMISSION CONTROL AND PROPER VEHICLE PERFORMANCE**

Inspection and Service should also be performed any time a malfunction is observed or suspected.

0 = Except California Vehicles

COMPONENT	SERVICE INTERVAL	MILEAGE IN THOUSANDS		7.5	15	22.5	30	37.5	45	52.5	60
		KILOMETERS IN THOUSANDS		12	24	36	48	60	72	84	96
CHANGE ENGINE OIL EVERY 6 MONTHS	OR	X	X	X	X	X	X	X	X	0	0
CHANGE ENGINE OIL FILTER EVERY SECOND OIL CHANGE (1)	OR		X			X			X		0
REPLACE SPARK PLUGS	AT					X					0
REPLACE ENGINE AIR FILTER AND PCV FILTER	AT					X					0
REPLACE OXYGEN SENSOR	AT										
REPLACE DISTRIBUTOR CAP & ROTOR (EXCEPT 3.3L)	AT										0*
REPLACE PCV VALVE	AT										0*
REPLACE VACUUM OPERATED EMISSION COMPONENTS (REFER TO GROUP 25)	AT										0
INSPECT TIMING BELT 3.0L ONLY	AT										0
ADJUST IGNITION TIMING IF NOT TO SPECIFICATIONS	AT										0
REPLACE IGNITION CABLES	AT										0
INSPECT DRIVE BELTS (AUTO TENSION) REPLACE AS NECESSARY	AT										0
INSPECT AND ADJUST DRIVE BELTS (NON-AUTO TENSION)	AT		X			X			X		
REPLACE DRIVE BELT (NON-AUTO TENSION)	AT										0
CHECK ENGINE COOLANT CONDITION, COOLANT HOSES & CLAMPS	AT	X	X	X	X	X	X	X	X	0	0
FLUSH AND REPLACE ENGINE COOLANT AT 36 MONTHS (4)	AT									X	
INSPECT EXHAUST SYSTEM	AT	X	X	X	X	X	X	X	X	0	0

COMPONENT	SERVICE INTERVAL	MILEAGE IN THOUSANDS		67.5	75	82.5	90	97.5	105	112.5	120
		KILOMETERS IN THOUSANDS		108	120	132	144	156	168	180	192
CHANGE ENGINE OIL EVERY 6 MONTHS	OR	0	0	0	0	0	0	0	0	0	0
CHANGE ENGINE OIL FILTER EVERY SECOND OIL CHANGE (1)	OR		0			0			0		0
REPLACE SPARK PLUGS	AT					0					0
REPLACE ENGINE AIR FILTER AND PCV FILTER	AT					0					0
REPLACE OXYGEN SENSOR	AT			0*							
REPLACE DISTRIBUTOR CAP & ROTOR (EXCEPT 3.3L)	AT										0
REPLACE PCV VALVE	AT										0*
REPLACE VACUUM OPERATED EMISSION COMPONENTS (REFER TO GROUP 25)	AT										0
INSPECT TIMING BELT 3.0L ONLY	AT										0
ADJUST IGNITION TIMING IF NOT TO SPECIFICATIONS	AT										0
REPLACE IGNITION CABLES	AT										0
INSPECT DRIVE BELTS (AUTO TENSION) REPLACE AS NECESSARY	AT		0 <sup>2</sup>			0 <sup>2</sup>			0 <sup>2</sup>		0 <sup>3</sup>
INSPECT AND ADJUST DRIVE BELTS (NON-AUTO TENSION)	AT		X			X			X		
REPLACE DRIVE BELT (NON-AUTO TENSION)	AT										0
CHECK ENGINE COOLANT CONDITION, COOLANT HOSES & CLAMPS	AT	0	0	0	0	0	0	0	0	0	0
INSPECT EXHAUST SYSTEM	AT	0	0	0	0	0	0	0	0	0	0

(1) Note: If mileage is less than 7,500 miles (12 000 km) each 12 months, replace oil filter at each oil change.

(2) Not required if belt was previously replaced.

(3) Not required if belt was replaced at 120, 144 or 168 thousand kilometers.

(4) Flush and replace engine coolant every 24 months 48 000 km (30,000 miles) thereafter.

\*Service when Emissions Maintenance Lamp remains on continuously with key ON.



GENERAL MAINTENANCE SCHEDULES

GENERAL MAINTENANCE SERVICES FOR PROPER VEHICLE PERFORMANCE

General Maintenance	Service Intervals	Mileage in Thousands						
		7.5	15	22.5	30	37.5	45	
		Kilometers in Thousands						
		12	24	36	48	60	72	
Check & Service As Required Every 12 Months								
<b>Cooling System</b>	Drain, Flush, and Refill At 36 Months Or 52,500 Miles (84 000 Kilometers) And Every 24 Months Or 30,000 Miles (48 000 Kilometers) Thereafter							
<b>Brake Hoses</b>	Inspect For Deterioration And Leaks Whenever Brake System is Serviced And Every 7,500 Miles (12 000 km) Or 12 Months, Whichever Occurs First, For Non-turbocharged Vehicles and 7,500 Miles (12 000 km) or 6 Months, Whichever Occurs First, For Turbocharged Vehicles Replace if Necessary.							
<b>Brake Linings—Front</b>	Inspect	At		X			X	
<b>Brake Linings—Rear</b>	Inspect	At		X			X	
<b>Rear Wheel Bearings</b>	Inspect	At		X			X	
<b>Tie Rod Ends and Steering Linkage</b>	Lubricate Every 3 Years If Equipped With Fittings	Or				X		
<b>CV Joint Boots</b>	Inspect For Deterioration And Leaks Every Oil Change. Replace if Necessary.	Or	X	X	X	X	X	
<b>Tire Rotation</b>	At		X	24 000 km (15,000 mi) Thereafter				
<b>Driver Supplemental Airbag System</b>	Inspect Every 3 Years Or 30,000 Miles (48 000 Kilometers) And Correct as Necessary: — System Components For Damage Or Deterioration — Diagnostic Unit For Stored Malfunction Messages — Readiness Indicator (Airbag Lamp) Function					X		

9200-4

SEVERE SERVICE SCHEDULES

SEVERE SERVICE MAINTENANCE\*

Service Intervals	Mileage in Thousands																	
	3	6	9	12	15	18	21	24	27	30	33	36	39	42	45	48		
		Kilometers in Thousands																
		4.8	9.6	14	19	24	29	34	38	43	48	53	58	62	67	72	77	
<b>Brake Linings (Front &amp; Rear) and Rear Wheel Bearings</b>	Inspect			X		X			X			X				X		
<b>Constant Velocity Universal Joints</b>	Inspect at every oil change																	
<b>Engine Oil Engine Oil Filter</b>	Refer to Frequency of Engine Oil and Filter Changes Paragraph in Engine Section of this Group																	
<b>Front Suspension Ball Joints</b>	Inspect at every oil change																	
<b>Transmission Fluid and Filter—Automatic</b>	Change at (adjust bands at time of fluid and filter change)					X				X						X		
<b>Steering Linkage Tie Rod Ends</b>	Lubricate every 18 months If Equipped With Fittings or					X				X						X		
<b>Engine Air Filter</b>	Inspect and replace if required					X				X						X		
<b>Power Transfer Unit</b>	Change Lubricant at				X					X				X			X	
<b>Overrunning Clutch</b>	Change Fluid at									X						X		
<b>Drive Line Module</b>	Change Lubricant at									X						X		

\*Driving under any of the following operating conditions: Stop and go driving in dusty conditions, extensive idling, frequent short trips, operating at sustained high speeds during hot weather above +30°C (+90°F).

FLUID CAPACITIES

<b>Engine Cooling System</b>	<b>Liters</b>	<b>U.S. Qts.</b>
2.5L .....	9.0	9.5
3.0L or 3.3L .....	9.5	10.0
These capacities include .47 Liter (1 pint) for recovery tank. ADD 0.95 Liters (1 qt.) when equipped with rear heater.		
<b>Engine Crankcase*</b>	<b>Liters</b>	<b>U.S. Qts.</b>
All .....	3.8	4.0
*Includes 0.4 liters (0.5 qts.) for filter change		
<b>Transaxle</b>	<b>Liters</b>	<b>U.S. Qts.</b>
Service Fill Estimated Capacity		
All automatic transaxles .....	3.8	4.0
Overhaul Fill Capacity with converter empty		
3-speed automatic Fleet .....	8.7	9.2
3-speed automatic except Fleet .....	8.0	8.5
4-speed automatic .....	8.6	9.1
5-speed Manual, Fill to bottom of fill hole .....	2.3	2.4
<b>Power Transfer Unit</b>	<b>Liters</b>	<b>Fl. Ozs.</b>
Fill to bottom of fill hole.		
All .....	1.15	38.8
<b>Overrunning Clutch</b>	<b>Liters</b>	<b>Fl. Ozs.</b>
Fill to bottom of fill hole.		
All .....	0.37	12.4
<b>Drive Line Module</b>	<b>Liters</b>	<b>Fl. Ozs.</b>
Fill to bottom of fill hole.		
All .....	1.9	64.2
<b>Power Steering</b>	<b>Liters</b>	<b>U.S. Pints</b>
All .....	0.81	1.7
<b>Fuel Tank</b>	<b>Liters</b>	<b>U.S. Gal.</b>
All Wheel Drive .....	68.0	18.0
Front Wheel Drive .....	75.7	20.0
		9200-6X

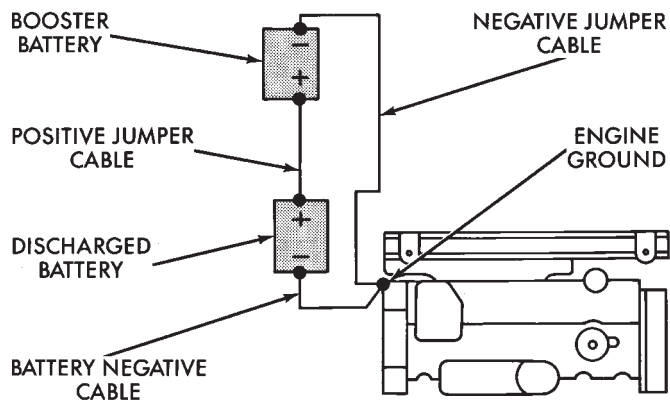

DO NOT ALLOW VEHICLES TO TOUCH

9100-3

Fig. 1 Jumper Cable Clamp Connections

**CAUTION:** Do not crank starter motor on disabled vehicle for more than 15 seconds, starter will over-heat and could fail.

(6) Allow battery in disabled vehicle to charge to at least 12.4 volts (75% charge) before attempting to start engine. If engine does not start within 15 seconds, stop cranking engine and allow starter to cool (15 min.), before cranking again.

DISCONNECT CABLE CLAMPS AS FOLLOWS:

- Disconnect BLACK cable clamp from engine ground on disabled vehicle.
- When using a Booster vehicle, disconnect BLACK cable clamp from battery negative terminal. Disconnect RED cable clamp from battery positive terminal.
- Disconnect RED cable clamp from battery positive terminal on disabled vehicle.

**HOISTING RECOMMENDATIONS**

Refer to Owner's Manual provided with vehicle for proper emergency jacking procedures.

**WARNING:** THE HOISTING AND JACK LIFTING POINTS PROVIDED ARE FOR A COMPLETE VEHICLE. WHEN THE ENGINE OR REAR SUSPENSION IS REMOVED FROM A VEHICLE, THE CENTER OF GRAVITY IS ALTERED MAKING SOME HOISTING CONDITIONS UNSTABLE. PROPERLY SUPPORT OR SECURE VEHICLE TO HOISTING DEVICE WHEN THESE CONDITIONS EXIST.





TO HOIST OR JACK VEHICLE SEE FIG. 2

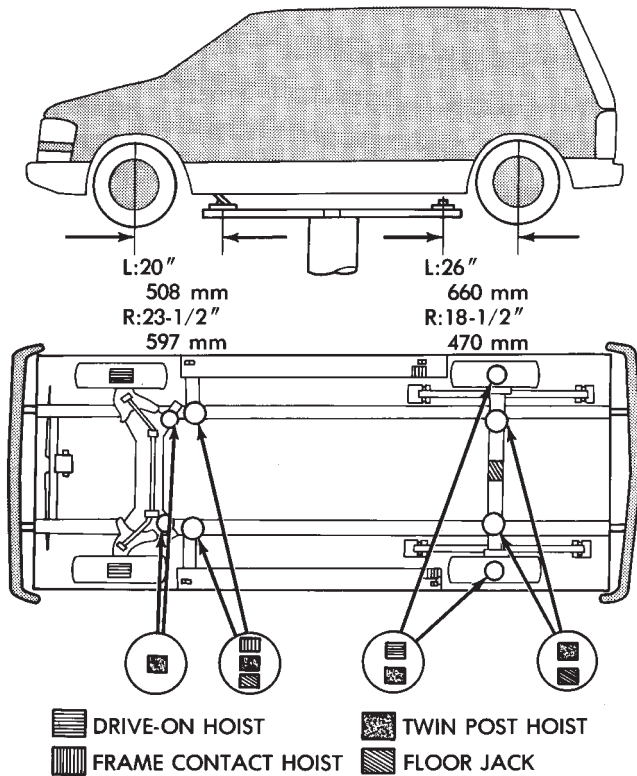

9100-18

Fig. 2 Hoisting and Jacking Points

TOWING RECOMMENDATIONS

RECOMMENDED TOWING EQUIPMENT

To avoid damage to bumper fascia and air dams use of a wheel lift or flat bed towing device (Fig. 3) is recommended. When using a wheel lift towing device, be sure the unlifted end of disabled vehicle has at least 100 mm (4 in.) ground clearance. If minimum ground clearance cannot be reached, use a towing dolly. If a flat bed device is used, the approach angle should not exceed 15 degrees.



WHEEL LIFT

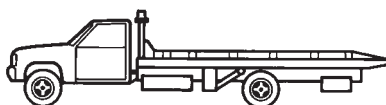

FLAT BED

9100-17

Fig. 3 Recommended Towing Devices

GROUND CLEARANCE

**CAUTION:** If vehicle is towed with wheels removed, install lug nuts to retain brake drums or rotors.

A towed vehicle should be raised until lifted wheels are a minimum 100 mm (4 in) from the ground. Be sure there is adequate ground clearance at the opposite end of the vehicle, especially when towing over rough terrain or steep rises in the road. If necessary, remove the wheels from the lifted end of the vehicle and lower the vehicle closer to the ground, to increase the ground clearance at the opposite end of the vehicle. Install lug nuts on wheel attaching studs to retain brake drums or rotors.

LOCKED VEHICLE TOWING

When a locked vehicle must be towed with the front wheels on the ground, use a towing dolly or flat bed hauler.

FLAT TOWING WITH TOW BAR

- Manual transaxle vehicles can be flat towed at any legal highway speed with no distance restrictions. The steering column must be unlocked and gear selector in neutral.
- 4-speed automatic transaxle vehicles can be flat towed at speeds not to exceed 72 km/h (44 mph) for not more than 160 km (100 miles). The steering column must be unlocked and gear selector in neutral.
- 3-speed automatic transaxle vehicles can be flat towed at speeds not to exceed 40 km/h (25 mph) for not more than 25 km (15 miles). The steering column must be unlocked and gear selector in neutral.

**WARNING: DO NOT ALLOW TOWING ATTACHMENT DEVICES TO CONTACT THE FUEL TANK OR LINES, FUEL LEAK CAN RESULT.**

**DO NOT LIFT OR TOW VEHICLE BY FRONT OR REAR BUMPER, OR BUMPER ENERGY ABSORBER UNITS.**

**DO NOT VENTURE UNDER A LIFTED VEHICLE IF NOT SUPPORTED PROPERLY ON SAFETY STANDS.**

**DO NOT ALLOW PASSENGERS TO RIDE IN A TOWED VEHICLE.**

**USE A SAFETY CHAIN THAT IS INDEPENDENT FROM THE TOWING ATTACHMENT DEVICE.**

**CAUTION:** Do not damage brake lines, exhaust system, shock absorbers, sway bars, or any other under vehicle components when attaching towing device to vehicle.

Remove or secure loose or protruding objects from a damaged vehicle before towing.

**Refer to state and local rules and regulations before towing a vehicle.**

**Do not allow weight of towed vehicle to bear on lower fascia, air dams, or spoilers.**

*TOWING—FRONT WHEEL LIFT*

Chrysler Corporation recommends that a vehicle be towed with the front end lifted, whenever possible.

*TOWING—REAR WHEEL LIFT*

If a front wheel drive vehicle cannot be towed with the front wheels lifted, the rear wheels can be lifted provided the following guide lines are observed.

**CAUTION: Do not use steering column lock to secure steering wheel during towing operation.**

- Unlock steering column and secure steering wheel in straight ahead position with a clamp device designed for towing.
- Verify that front drive line and steering components are in good condition.
- 4-speed automatic transaxle vehicles can be towed at speeds not to exceed 72 km/h (44 mph) for not more than 160 km (100 miles). The gear selector must be in neutral position.
- 3-speed automatic transaxle vehicles can be towed at speeds not to exceed 40 km/h (25 mph) for not more than 25 km (15 miles). The gear selector must be in neutral position.

ENGINE

INDEX

	page		page
Engine Oil Filter	10	Engine Oil	8
Battery	14	Frequency of Engine Oil and Filter Changes	8
Crankcase Ventilation System	12	Fuel Filter	14
Drive Belts	14	Fuel Recommendations	13
Emission Control System	14	Ignition Cables, Distributor Cap, and Rotor	14
Engine Air Cleaner	11	Rubber and Plastic Component Inspection	14
Engine Cooling System	10	Spark Plugs	14

**FREQUENCY OF ENGINE OIL AND FILTER CHANGES**

*ENGINE OIL*

Road conditions as well as your kind of driving affect the interval at which your oil should be changed. Check the following to determine if any apply to you:

- Frequent short trip driving less than 8 kilometers (5 miles)
- Frequent driving in dusty conditions
- Frequent trailer towing
- Extensive idling (such as vehicle operation in stop and go traffic)
- More than 50% of your driving is at sustained high speeds during hot weather, above 32°C (90°F)

If **any** of these apply to you then change your engine oil every 4 800 kilometers (3,000 miles) or 3 months, whichever comes first.

If none of these apply to you then change your oil every 12 000 kilometers (7,500 miles) or 6 months, whichever comes first.

If none of these apply and the vehicle is in commercial type service such as, Police, Taxi or Limousine used for highway driving of 40 kilometers (25 miles) or more between stations, the engine oil should be changed every 8 000 kilometers (5,000 miles) or 6 months.

*OIL FILTER*

The engine oil filter should be replaced with a new filter at every second oil change.

**ENGINE OIL**

**WARNING: NEW OR USED ENGINE OIL CAN BE IRRITATING TO THE SKIN. AVOID PROLONGED OR REPEATED SKIN CONTACT WITH ENGINE OIL. CONTAMINANTS IN USED ENGINE OIL, CAUSED BY INTERNAL COMBUSTION, CAN BE HAZARDOUS TO YOUR HEALTH. THOROUGHLY WASH EXPOSED SKIN WITH SOAP AND WATER.**

**DO NOT WASH SKIN WITH GASOLINE, DIESEL FUEL, THINNER, OR SOLVENTS, HEALTH PROBLEMS CAN RESULT.**

**DO NOT POLLUTE, DISPOSE OF USED ENGINE OIL PROPERLY. CONTACT YOUR DEALER OR GOVERNMENT AGENCY FOR LOCATION OF COLLECTION CENTER IN YOUR AREA..**

*BREAK-IN PERIOD*

**CAUTION: Wide open throttle operation in low gears, before engine break-in period is complete, can damage engine.**

On a Chrysler Corporation vehicle an extended break-in period is not required. Driving speeds of not over 80-90 km/h (50-55 mph) for the first 100 km (60 miles) is recommended. Hard acceleration and high engine rpm in lower gears should be avoided.

*SELECTING ENGINE OIL*

**CAUTION: Do not use non-detergent or straight mineral oil when adding or changing crankcase lubricant. Engine or Turbocharger failure can result.**

The factory fill engine oil is a high quality, energy conserving, crankcase lubricant. The Recommended SAE Viscosity Grades chart defines the viscosity grades that must be used based on temperature in the region where vehicle is operated (Fig. 1) and optional equipment.

Chrysler Corporation recommends that Mopar® motor oil, or equivalent, be used when adding or changing crankcase lubricant. The API symbol (Fig. 2) on the container indicates the viscosity grade, quality and fuel economy ratings of the lubricant it contains. Use ENERGY CONSERVING II motor oil with API SERVICE SG or SG/CD classification.

- SG service engine oil is a high quality crankcase lubricant designed for use in all naturally aspirated engines.
- SG/CD service engine oil is a high quality crankcase lubricant designed for use in most naturally aspirated and turbocharged gasoline or diesel engines.
- SAE 5W-30 engine oil is recommended for use in 3.0L and 3.3L engines in temperatures below 38°C



(100°F) to reduce low temperature cranking effort. SAE 5W-30 engine oil is not recommended for use in 2.5L engine in temperatures above 0°C (32°F).

- SAE 10W-30 engine oil is recommended for use in 2.5L engine in temperatures above -18°C (0°F).

RECOMMENDED VISCOSITY GRADES

		10W-30							
		5W-30 EXCEPT 2.5 L ENGINE							
		5W-30 2.5 L ENGINE							
F-20	0	10	20	32	60	80	100		
C-29	-18	-12	-7	0	16	27	38		
TEMPERATURE RANGE ANTICIPATED BEFORE NEXT OIL CHANGE.									

9100-19



RN952

**Fig. 1 Shaded Areas Cover Regions Where Minimum Temperatures Can Be Consistently Below -12°C (10°F) During Winter Seasons.**

ENGINE OIL ADDITIVES

Chrysler Corporation recommends that Mopar® Engine Oil Supplement or equivalent be used when friction and corrosion reducing materials added to the crankcase lubricant is desired.

CRANKCASE OIL LEVEL INSPECTION

**CAUTION:** Do not overfill crankcase with engine oil, oil foaming and oil pressure loss can result.

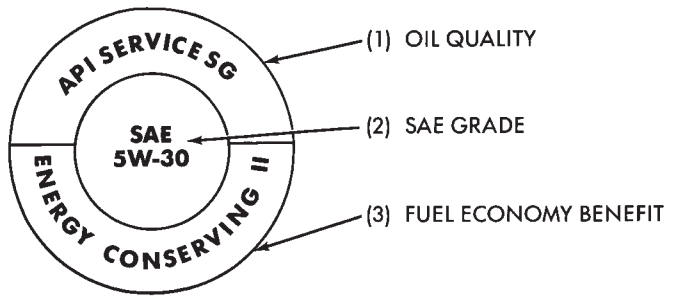

9100-5

**Fig. 2 API Symbol**

Inspect engine oil level approximately every 800 kilometers (500 miles). Position vehicle on level surface. With engine OFF, allow enough time for oil to settle to bottom of crankcase, remove engine oil level indicator (dipstick) and wipe clean. Install dipstick and verify it is seated in the tube. Remove dipstick, with handle above tip, take oil level reading (Fig. 3). Add oil only if level is below MIN or ADD mark on dipstick.

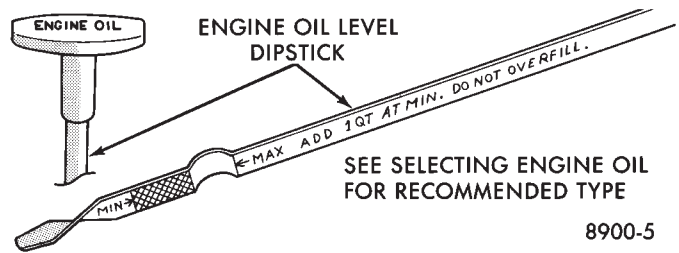

8900-5

**Fig. 3 Oil Level Indicator Dipstick—Typical**

ENGINE OIL CHANGE

Change engine oil at mileage and time intervals described in Lubrication and Maintenance Schedules.

TO CHANGE ENGINE OIL:

- (1) Position the vehicle on a level surface.
- (2) Hoist and support vehicle on safety stands. Refer to Hoisting and Jacking Recommendations in this group.
- (3) Place a suitable 3.8 liter (4 qt.) drain pan under crankcase drain.
- (4) Remove drain plug from crankcase and allow oil to drain into pan. Inspect drain plug threads for stretching or other damage. Replace drain plug and gasket if damaged.
- (5) Install drain plug in crankcase.
- (6) Lower vehicle and fill crankcase with specified type and amount of engine oil described in this section.
- (7) Start engine and inspect for leaks.
- (8) Stop engine and inspect oil level.

## ENGINE OIL FILTER

### SELECTING OIL FILTER

Chrysler Corporation recommends a Mopar® or equivalent oil filter be used when replacement is required. A replacement filter must be designed to withstand 1756 kPa (256 psi) of internal pressure.

### OIL FILTER REMOVAL:

- (1) Position a drain pan under the oil filter.
- (2) Using a suitable oil filter wrench (Fig. 4) loosen filter.
- (3) When filter separates from adapter nipple, tip gasket end upward to minimize oil spill. Remove filter from vehicle.
- (4) With a wiping cloth, clean the gasket sealing surface (Fig. 5) of oil and grime. Wipe off oil residue from below oil filter adapter.

### OIL FILTER INSTALLATION:

- (1) Lightly lubricate oil filter gasket with engine oil or chassis grease.
- (2) Thread filter onto adapter nipple. When gasket makes contact with sealing surface, tighten filter one full turn. If necessary use a filter wrench, do not over tighten.
- (3) Add oil, verify crankcase oil level and start engine. Inspect for oil leaks.

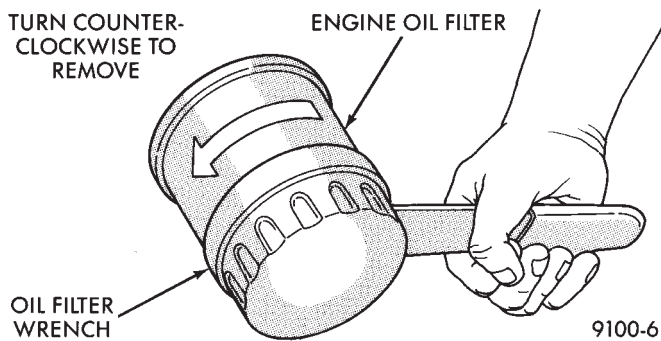

Fig. 4 Remove Oil Filter

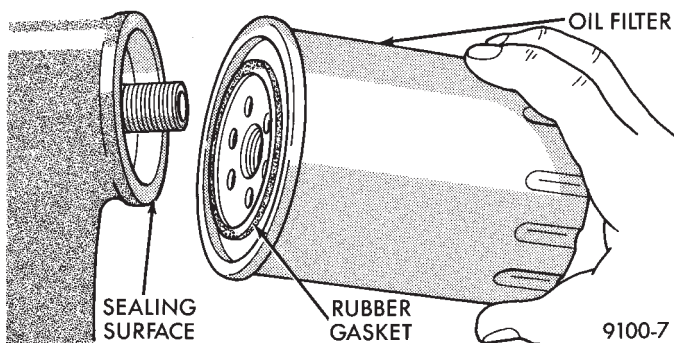

Fig. 5 Install Oil Filter

## ENGINE COOLING SYSTEM

### WARNINGS AND PRECAUTIONS

**WARNING: ANTIFREEZE IS AN ETHYLENE GLYCOL BASE COOLANT AND IS HARMFUL IF SWALLOWED OR INHALED. IF SWALLOWED, DRINK TWO GLASSES OF WATER AND INDUCE VOMITING. IF INHALED, MOVE TO FRESH AIR AREA. SEEK MEDICAL ATTENTION IMMEDIATELY. DO NOT STORE IN OPEN OR UNMARKED CONTAINERS. WASH SKIN AND CLOTHING THOROUGHLY AFTER COMING IN CONTACT WITH ETHYLENE GLYCOL. KEEP OUT OF REACH OF CHILDREN.**

**DISPOSE OF GLYCOL BASE COOLANT PROPERLY, CONTACT YOUR DEALER OR GOVERNMENT AGENCY FOR LOCATION OF COLLECTION CENTER IN YOUR AREA.**

**DO NOT OPEN A COOLING SYSTEM WHEN THE ENGINE IS AT RUNNING TEMPERATURE, PERSONAL INJURY CAN RESULT.**

**AVOID RADIATOR COOLING FAN WHEN ENGINE COMPARTMENT RELATED SERVICE IS PERFORMED, PERSONAL INJURY CAN RESULT.**

**CAUTION: Do not use straight antifreeze as engine coolant, inadequate engine running temperatures can result.**

**Do not operate vehicle without proper concentration of recommended ethylene glycol coolant, high running temperatures and cooling system corrosion can result.**

The engine cooling system will develop internal pressure of 97 to 123 kPa (14 to 18 psi) at normal operating temperature. Allow the vehicle approximately one half hour to cool off before opening the cooling system. As an indicator of pressure, squeeze the upper radiator hose between index finger and thumb. If it collapses with little effort the system would have low internal pressure and should be safe to open to the first safety notch of the radiator cap. Refer to Group 7, Cooling System.

### COOLING SYSTEM INSPECTION

Coolant level (Fig. 6) should be inspected when other engine compartment service is performed or when coolant leak is suspected. Coolant recovery tank level should read between the MIN and MAX marks, located on the side of recovery tank, when the engine is at normal operating temperature. Normal coolant level maintenance does not require the removal of radiator cap. Cooling system freeze protection should be tested at the onset of the winter season or every 12 months. Service is required if coolant is low, contaminated, rusty or freeze protec-

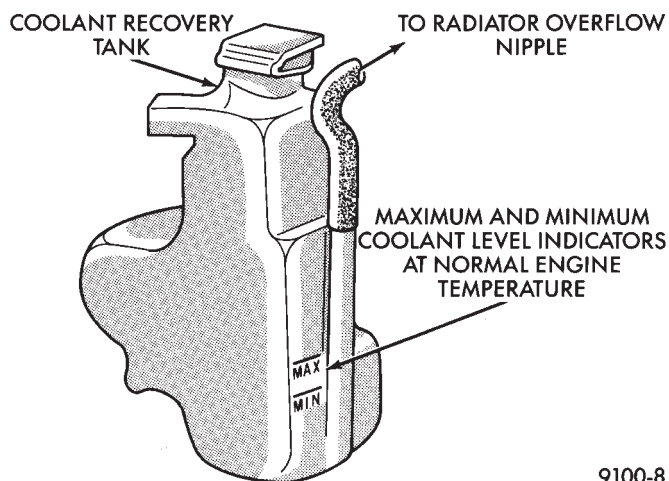

9100-8

**Fig. 6 Coolant Recovery Tank—Typical**

Mtion is inadequate. To properly test cooling system, see Group 7, Cooling System.

The cooling system factory fill is a mixture of 50% Glycol based antifreeze and 50% water. Using a suitable hydrometer, measure antifreeze concentration in the radiator when the engine is cool. If the cooling system has recently been serviced, allow coolant to circulate for at least 20 minutes before taking hydrometer reading. Properly mixed coolant will protect the cooling system to  $-37^{\circ}\text{C}$  ( $-35^{\circ}\text{F}$ ). If the freeze protection is above  $-28^{\circ}\text{C}$  ( $-20^{\circ}\text{F}$ ), drain enough coolant from the cooling system to allow room to add antifreeze to achieve adequate protection. A mix table on the coolant container indicates the amount of antifreeze required to winterize the cooling system based on the capacity, see Capacity Chart in General Information section of this group.

#### SELECTING ANTIFREEZE

Chrysler Corporation recommends Mopar® Antifreeze/Summer Coolant, or equivalent be used to winterize and protect cooling system.

#### RADIATOR CAP

The radiator cap must be secure to provide proper pressure release and coolant recovery. Inspect and test radiator cap when cooling system service is performed or when problem is suspected.

#### COOLING SYSTEM SERVICE

The cooling system should be drained, flushed and filled with the proper coolant mixture at the intervals described in the Lubrication and Maintenance Schedules. Refer to General Information section of this group. For proper service instructions see Group 7, Cooling System.

#### ENGINE AIR CLEANER

The engine air cleaner should be serviced at the intervals described in the Lubrication and Maintenance Schedules. Refer to General Information section

of this group. Additional information can be found in Group 14, Fuel System and Group 25, Emission System. Inspect all air cleaner hoses or tubes for damage or leaks when other engine compartment service is performed. Replace faulty components.

#### AIR CLEANER SERVICE

**CAUTION:** The air cleaner cover must be installed properly for the emissions system and engine controller to function correctly.

Do not immerse paper air filter element or temperature sensor in cleaning solvents, damage can result.

#### TO SERVICE AIR CLEANER ASSEMBLY:

- (1) Raise hood of vehicle and inspect all air cleaner components for damage or improper attachment.
- (2) Remove air cleaner cover (Figs. 7, 8 or 9).

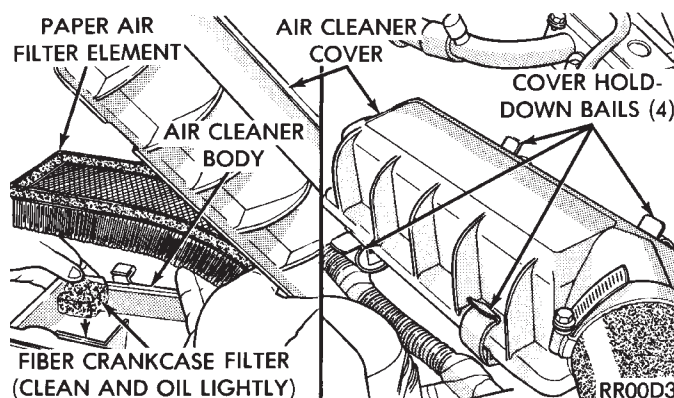

**Fig. 7 Air Cleaner Assembly—3.0L Engine**

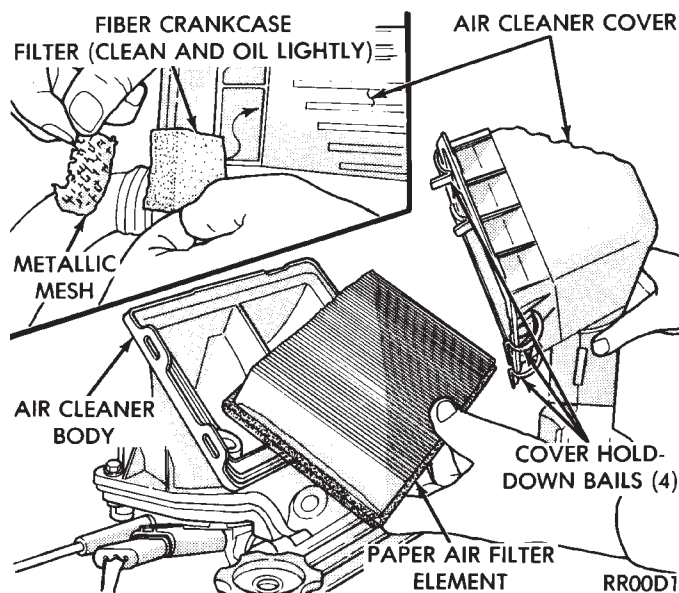

**Fig. 8 Air Cleaner Assembly—2.5L EFI Engine**

- (3) Remove paper air filter element from air cleaner body. Hold a shop light on throttle body side of element. Inspect air intake side of element. If light is visible through element, blow dust from element



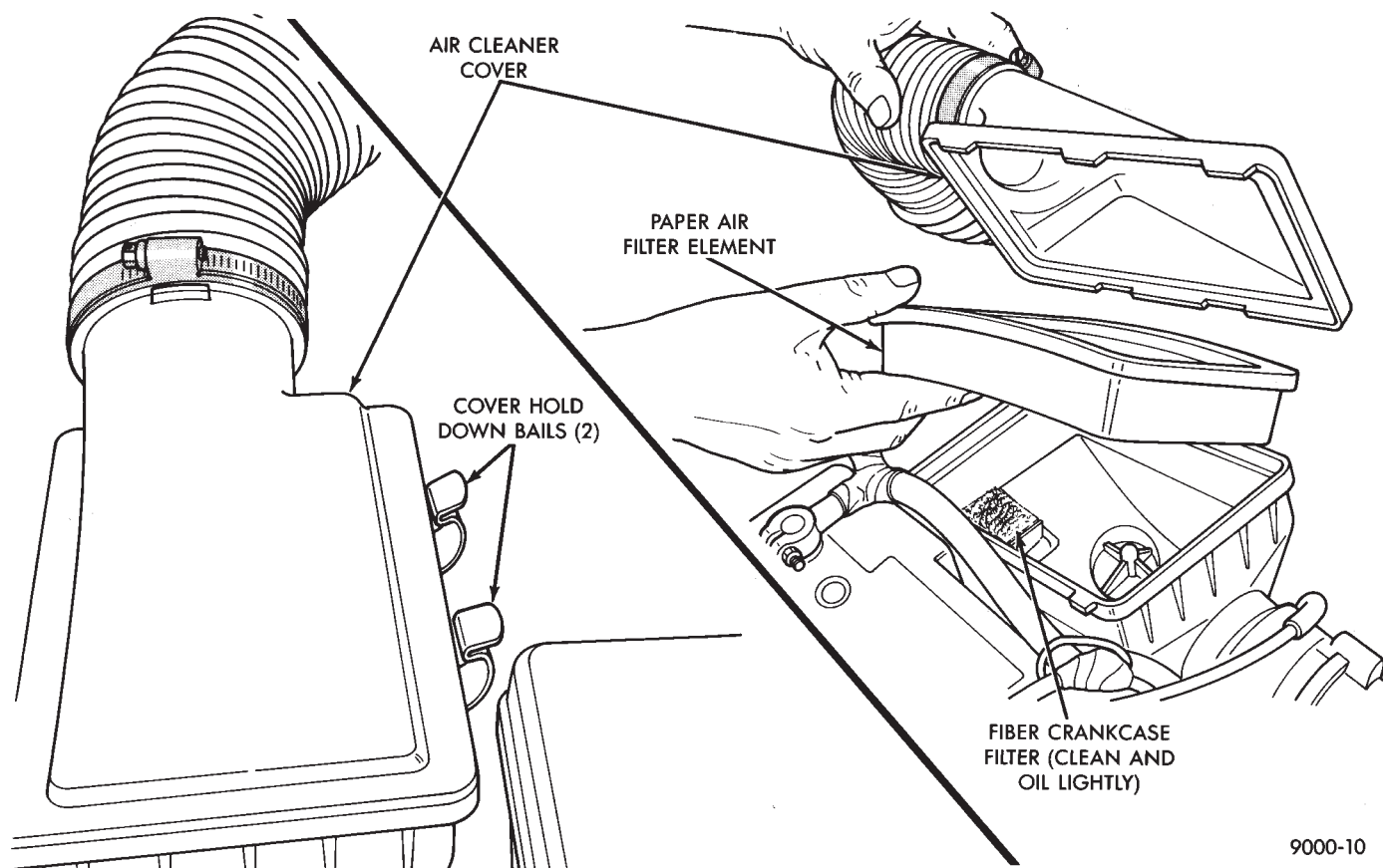

**Fig. 9 Air Cleaner Assembly—3.3L Engine**

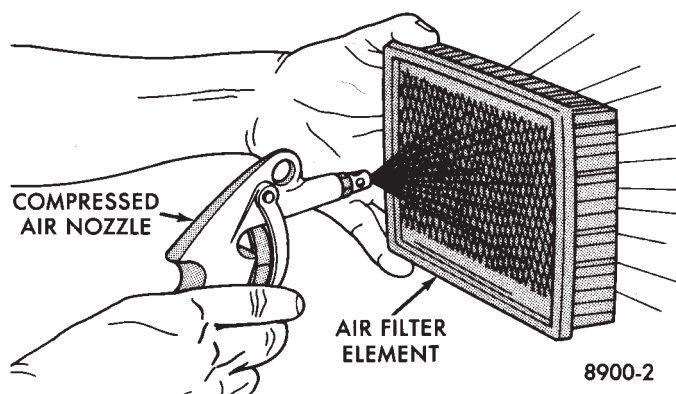

**Fig. 10 Cleaning Air Filter Element**

(Fig. 10) and reuse. If element is saturated with oil or light is not visible, replace filter. If element is saturated with oil, perform crankcase ventilation system tests.

(4) Remove fiber crankcase filter (Figs. 7, 8 or 9) and clean with solvent, squeeze filter dry and apply small amount of engine oil. If a metallic mesh is used to retain fiber filter, clean mesh with solvent and reuse.

(5) Clean inside of air cleaner cover and body with vacuum or compressed air. If oily, wash with solvent.

To Install, reverse the preceding operation.

## CRANKCASE VENTILATION SYSTEM

Engine crankcase pressure and emissions are vented into combustion chambers through the positive crankcase ventilation (PCV) system. The PCV system consists of a crankcase filter (Figs. 7, 8 or 9), PCV valve (Figs. 11, 12 or 13) and hoses to complete a vacuum circuit. The PCV system should have enough volume to overcome crankcase pressure created by piston backwash. If a PCV system becomes plugged, the crankcase pressure will increase and force engine oil past the piston rings creating oil consumption. Blockage of PCV system can occur at the vacuum source coupling, PCV valve, crankcase filter or a collapsed hose.

Chrysler Corporation recommends that a PCV valve not be cleaned. A new Mopar® or equivalent PCV valve should be installed when servicing is required. Over a period of time, depending on the environment where vehicle is used, deposits build up in the PCV vacuum circuit. PCV system should be inspected at every oil change. Service PCV system if engine oil is discharged into air cleaner.

## PCV SYSTEM TEST

(1) Verify that fiber crankcase filter is clean and properly installed in the air cleaner assembly.

(2) With the engine running at idle, remove crankcase inlet hose from the inlet filter nipple. Position a

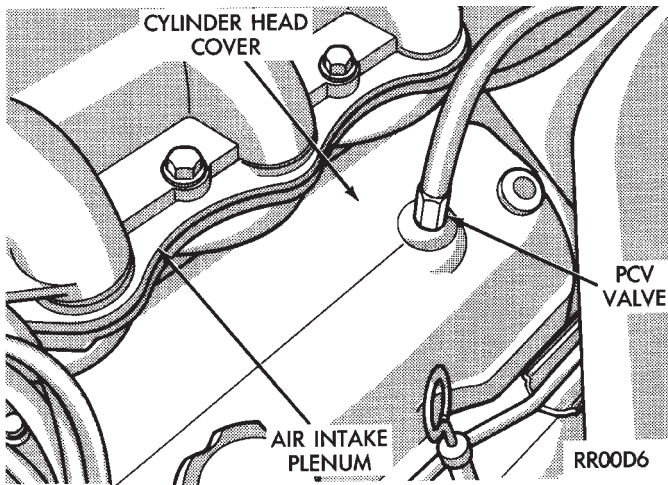

Fig. 11 PCV System—3.0L Engine

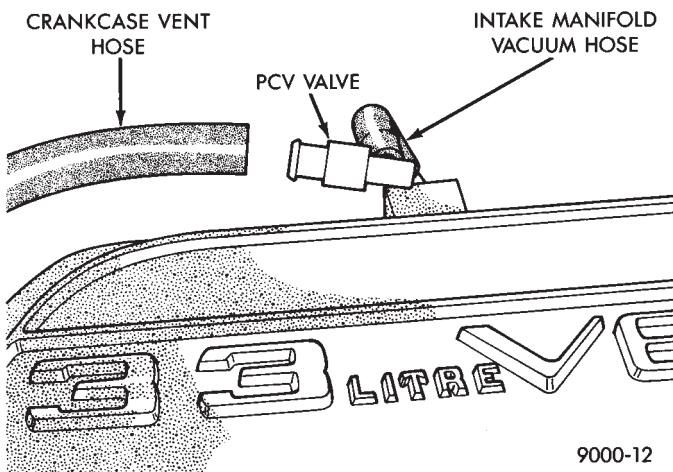

Fig. 12 PCV System—3.3L Engine

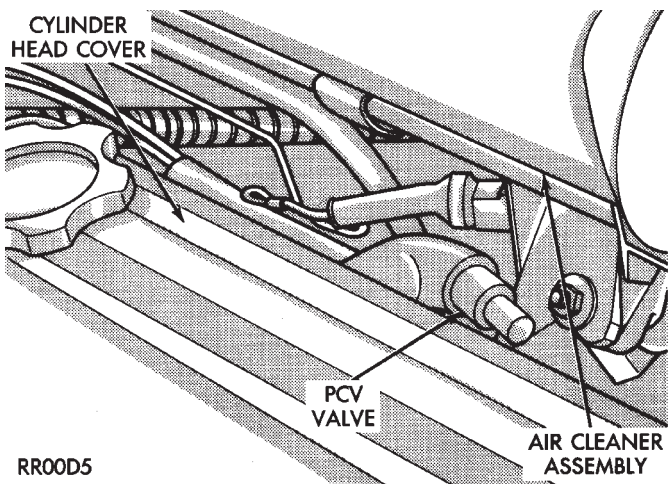

Fig. 13 PCV System—2.5L EFI Engine

50 mm (2 in.) square paper card over end of inlet hose. The card should be drawn to the end of the inlet hose within 15 seconds. If not, a leak or restriction exists in the PCV vacuum circuit.

(3) If card does not hold to end of inlet hose, disconnect PCV valve from cylinder head cover or adapter.

Vacuum hissing sound should be heard and engine should run steady. Place a finger over end of PCV valve (Fig. 14). The check valve in the PCV valve should click and rattle when PCV valve is shaken.

(4) Remove PCV valve from vacuum source hose. The engine should run very erratically or stall. If not, a vacuum restriction or blockage exists at the vacuum source.

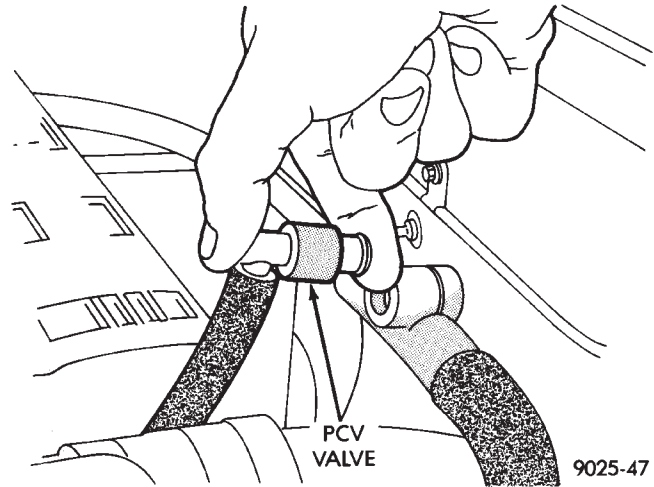

Fig. 14 PCV Valve Test

## FUEL RECOMMENDATIONS

Chrysler Corporation recommends that only fuel purchased from a reputable retailer be used. Use high quality, unleaded gasoline to provide satisfactory driveability and highest fuel economy. Gasoline containing detergent and corrosion control additives are desirable. If the engine develops spark knock (audible ping), poor performance, hard starting or stalling, purchase fuel from another source. Engine performance can vary when using different brands of gasoline with the same octane rating. Occasional light engine spark knock under heavy acceleration, at low speed or when vehicle is heavily loaded is not harmful. Extended periods of spark knock under moderate acceleration or at cruising speed can damage the engine. The cause of excessive spark knock condition must be diagnosed and corrected. For diagnostic procedures refer to Group 14, Fuel System and Powertrain Diagnostic Procedures manual.

## SELECTING GASOLINE

**CAUTION:** Do not use fuel containing METHANOL (methyl or wood alcohol), damage to fuel system will result.

Do not use leaded gasoline, damage to catalytic converter will result and vehicle will not conform to emission control standards.

### NON-BLENDED GASOLINE

Use regular unleaded gasoline having a minimum octane rating of 87 (R+M)/2. Higher octane premium unleaded gasoline can be used if desired.

### ETHANOL, MTBE OR ETBE BLENDS

All Chrysler Corporation vehicles are designed to use unleaded gasoline ONLY. Gasohol blends, containing 10% Ethanol (ethyl or grain alcohol) 90% unleaded gasoline can be used provided it has adequate octane rating. Fuel blends containing up to 15% MTBE (Methyl Tertiary Butyl Ether) and 85% unleaded gasoline can be used. Fuel blends containing up to 17% ETBE (Ethyl Tertiary Butyl Ether) and 83% unleaded gasoline can also be used.

Fuel blended with ethanol, MTBE or ETBE are also referred to as reformulated or clean air gasoline. These fuels contribute less emissions to the atmosphere. Chrysler Corporation recommends that blended fuels be used when available

### METHANOL BLENDS

Using gasoline blended with methanol can result in starting and driveability problems. Deterioration of fuel system components will result. Methanol induced problems are not the responsibility of Chrysler Corporation and may not be covered by the vehicle warranty.

### FUEL FILTER

The fuel filter requires service only when a fuel contamination problem is suspected. For proper diagnostic and service procedures refer to Group 14, Fuel System,

### IGNITION CABLES, DISTRIBUTOR CAP, AND ROTOR

Inspect and test ignition cables, distributor cap and rotor when the spark plugs are replaced. Oil and grime should be cleaned from the ignition cables and distributor cap to avoid possible spark plug fouling. Mopar®, Foamy Engine Degreaser, or equivalent is recommended for cleaning the engine compartment. For proper service and diagnostic procedures refer to Group 8D, Ignition System.

### SPARK PLUGS

Ignition spark plugs should be replaced at the mileage interval described in the Lubrication and Maintenance Schedules. Refer to the General Information section of this group. For proper service procedures refer to Group 8D, Ignition Systems.

### DRIVE BELTS

Inspect and adjust drive belts at the interval described in the Lubrication and Maintenance Schedules.

Refer to General Information section of this group. For proper inspection and adjustment procedures, see Group 7, Cooling System.

### EMISSION CONTROL SYSTEM

Inspect all emission control components and hoses when other under hood service is performed. Refer to emission system Vacuum Hose Label located on the inside of the hood in the engine compartment and Group 25, Emission Control Systems for proper service procedures.

### BATTERY

Inspect battery tray, hold down and terminal connections when other under hood service is performed. For proper diagnostic procedures refer to Group 8A, Battery/Starting/Charging System Diagnostics. For service and cleaning procedures refer to Group 8B, Battery/Starter Service.

### RUBBER AND PLASTIC COMPONENT INSPECTION

**CAUTION: Plastic hoses or wire harness covers will melt or deform when exposed to heat from exhaust system or engine manifolds.**

**Position plastic or rubber components away from moving parts in engine compartment or under vehicle, or damage will result.**

**Do not allow rubber engine mounts or other components to become oil contaminated, repair cause of oil contamination and clean area.**

All rubber and plastic components should be inspected when engine compartment or under vehicle service is performed. When evidence of deterioration exists, replacement is required. To reduce deterioration of rubber components, Chrysler Corporation recommends Mopar® Foamy Engine Degreaser or equivalent be used to clean engine compartment of oil and road grime.

### EXHAUST SYSTEM ISOLATOR AND HANGER

The exhaust system should be inspected when under vehicle service is performed. The exhaust system should not make contact with under body, brake cables, brake/fuel lines, fuel tank or suspension components. Slight cracking in rubber isolator or hanger is acceptable. Severely cracked or broken rubber components must be replaced. For proper service procedures see Group 11, Exhaust System and Intake Manifold.



## DRIVETRAIN

### INDEX

	page		page
Automatic Transaxle .....	15	Overrunning Clutch .....	16
Automatic Transaxle Shift Mechanism .....	15	Power Transfer Unit .....	16
Drive Line Module .....	17	Tires .....	18
Drive Shaft CV and Tripod Joint Boots .....	17		
Front Wheel Bearings (Rear Wheel Bearings on All Wheel Drive Models) .....	17		

### CLUTCH AND GEARSHIFT LINKAGE

If the clutch or gearshift begins to operate with difficulty, squeak or grunt, the cables and linkage should be lubricated before service replacement is performed. For proper lubrication and service procedures refer to Group 6, Clutch, or Group 21, Manual Transaxle.

### MANUAL TRANSAXLE

The manual transaxle should be inspected for oil leaks and proper oil level when other under vehicle service is performed. To inspect the transaxle oil level, position the vehicle on a level surface. Remove fill plug (Fig. 1) from the transaxle side cover. The oil level should not be below 4 mm (3/16 in) from bottom of oil fill opening.

The manual transaxle does not require periodic maintenance. The oil should be changed only when water contamination is suspected. If oil has a foamy or milky appearance it probably is contaminated. A circular magnet located behind the differential cover collects metallic particles circulating in the oil. For proper diagnostic and service procedures, refer to Group 21, Manual Transaxle.

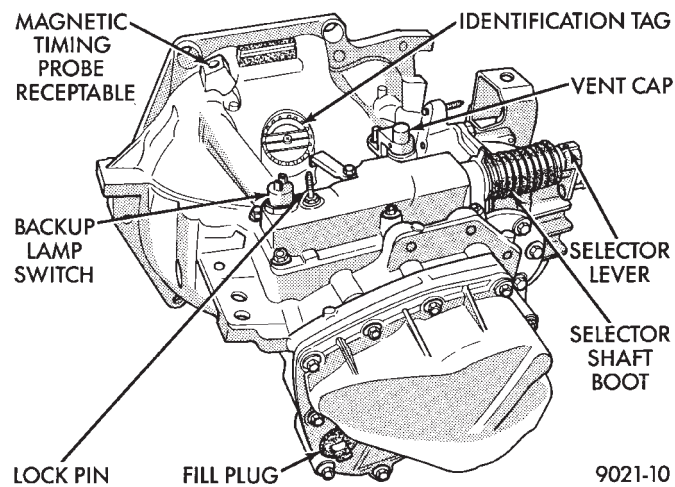

**Fig. 1 Manual Transaxle Fill Plug**

9021-10

### SELECTING MANUAL TRANSAXLE OIL

Chrysler Corporation recommends Mopar® Engine

Oil, SG or SG/CD SAE 5W-30, or equivalent, be used to fill a 5-speed transaxle.

### AUTOMATIC TRANSAXLE SHIFT MECHANISM

If the automatic transaxle shift mechanism becomes difficult to operate or starts to make objectionable noise, the mechanism should be lubricated before other service repair is performed. Apply a film of Mopar® Multipurpose Grease or equivalent, to slide surfaces and pawl spring. For additional information, refer to Group 21, Transaxle.

### AUTOMATIC TRANSAXLE

The automatic transaxle should be inspected for fluid leaks and proper fluid level when other under hood service is performed.

**CAUTION:** To minimize fluid contamination, verify that dipstick is seated in the fill hole or tube after fluid level reading is taken.

#### TO INSPECT THE TRANSAXLE FLUID LEVEL:

- (1) Position the vehicle on a level surface.
- (2) Start engine and allow to idle in PARK for at least 60 seconds. The warmer the transaxle fluid, the more accurate the reading.
- (3) While sitting in driver seat, apply brakes and place gear selector in each position. Return gear selector to park.
- (4) Raise hood and remove transaxle fluid level indicator (dipstick) and wipe clean with a suitable cloth.
- (5) Install dipstick and verify it is seated in fill hole or tube (Fig. 2 or 3).

**CAUTION:** Do not overfill automatic transaxle, leakage or damage can result.

- (6) Remove dipstick, with handle above tip, take fluid level reading (Fig. 4). If the vehicle has been driven for at least 15 minutes before inspecting fluid level, transaxle can be considered hot and reading should be above the WARM mark. If vehicle has run for less than 15 minutes and more than 60 seconds

transaxle can be considered warm and reading should be above ADD mark. Add fluid only if level is below ADD mark on dipstick when transaxle is warm.

The automatic transaxle does not require periodic maintenance when used for general transportation. If the vehicle is subjected to severe service conditions, the automatic transaxle will require fluid/filter change and band adjustments every 24 000 km (15,000 miles). For additional information, refer to Severe Service paragraph and Lubrication and Maintenance Schedules in General Information section of this group. The fluid and filter should be changed when water contamination is suspected. If fluid has foamy or milky appearance, it is probably contaminated. If the fluid appears brown or dark and a foul odor is apparent, the fluid is burned, transaxle requires maintenance or service. A circular magnet located in the transaxle pan, collects metallic particles circulating in the oil. For proper diagnostic and service procedures, refer to Group 21, Automatic Transaxle.

#### SELECTING AUTOMATIC TRANSAXLE FLUID

Chrysler Corporation recommends Mopar® ATF Plus (automatic transmission fluid type 7176) be used to add to or replace automatic transaxle fluid. If ATF Plus is not available use Mopar® Dexron II® Automatic Transmission Fluid or equivalent.

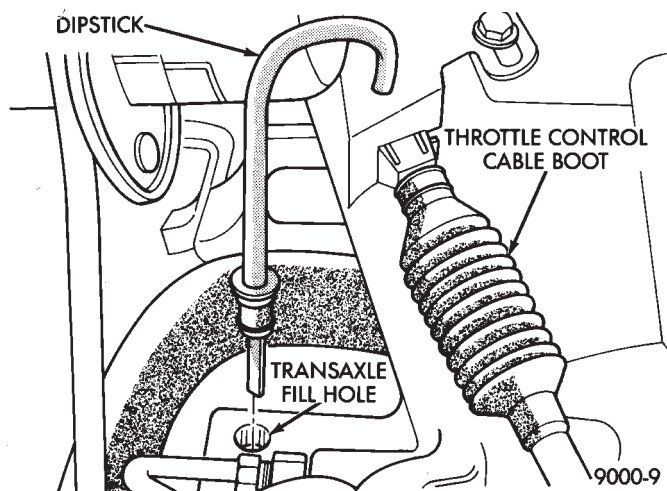
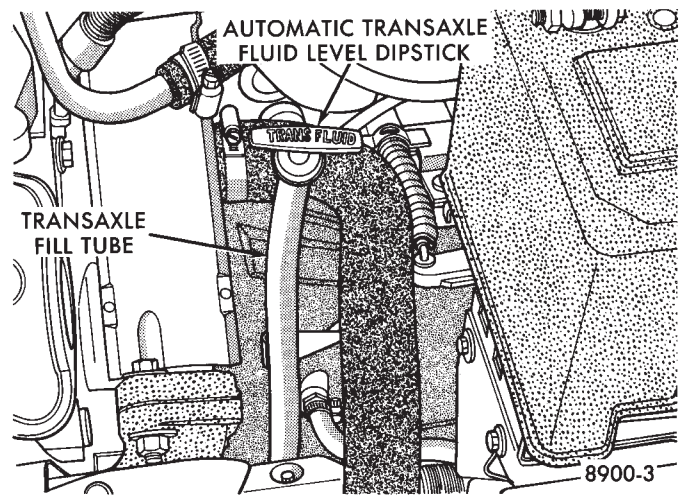

**Fig. 2 Automatic Transaxle Fill hole**

#### POWER TRANSFER UNIT

The All Wheel Drive (AWD) power transfer unit should be inspected for oil leaks and proper oil level when other under vehicle service is performed. To inspect the power transfer unit oil level, position the vehicle on a level surface and remove the fill plug (Fig. 5) from the unit. The oil level should be at the bottom edge of oil fill opening.

The power transfer unit does not require periodic maintenance when subjected to normal driving conditions. The oil should be changed when water contamination is suspected. If oil has foamy or milky appearance it probably is contaminated. If the vehicle is



**Fig. 3 Automatic Transaxle Fill tube**

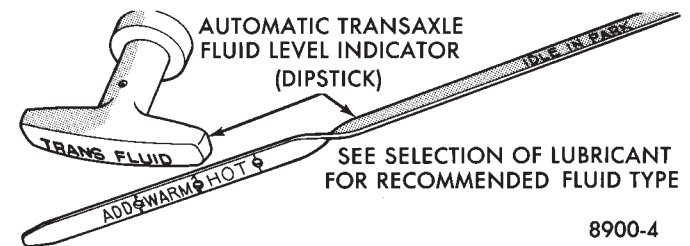

**Fig. 4 Automatic Transaxle Dipstick—Typical**

subjected to severe driving conditions, the power transfer unit would require periodic maintenance every 29 000 km (12,000 miles). Refer to Severe Service paragraph in General Information of this group for definition of severe service. A magnet located in the unit to collect metallic particles circulating in the oil. For proper diagnostic and service procedures, refer to Group 21, Transaxle/Power Transfer Unit.

#### SELECTING LUBRICANT

Chrysler Corporation recommends Mopar® Gear Lube, SAE 85W-90, or equivalent, be used to fill the power transfer unit.

#### OVERRUNNING CLUTCH

The All Wheel Drive (AWD) overrunning clutch should be inspected for oil leaks and proper oil level when other under vehicle service is performed. To inspect the overrunning clutch oil level, position the vehicle on a level surface and remove the fill plug (Fig. 6) from the unit. The oil level should be at the bottom edge of oil fill opening.

The overrunning clutch does not require periodic maintenance when subjected to normal driving conditions. The oil should be changed when water contamination is suspected. If oil has foamy or milky appearance it probably is contaminated. If the vehi-



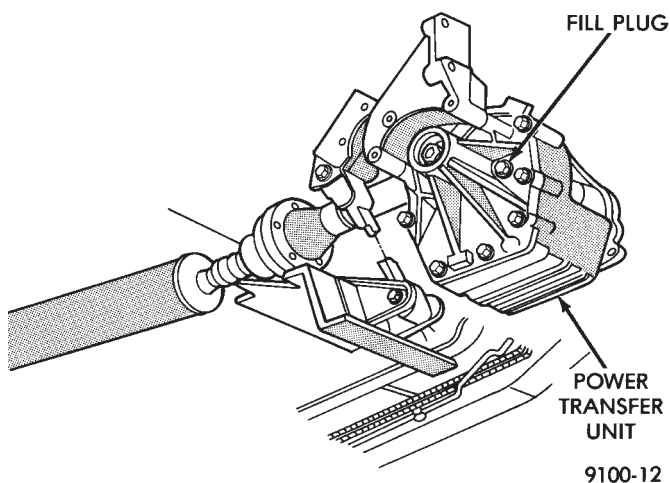
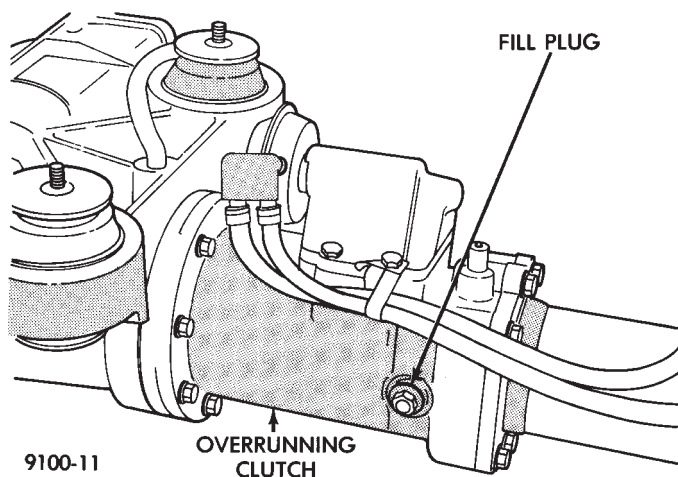

**Fig. 5 Power Transfer Unit Fill Plug**

When the vehicle is subjected to severe driving conditions the overrunning clutch would require periodic maintenance every 36 000 km (22,500 miles). Refer to Severe Service paragraph in General Information of this group for definition of severe service. For proper diagnostic and service procedures, refer to Group 3, Rear Suspension and Driveline.

#### SELECTING LUBRICANT

Chrysler Corporation recommends Mopar® ATF Plus (automatic transmission fluid type 7176) or equivalent, be used to add to or replace overrunning clutch fluid.



**Fig. 6 Overrunning Clutch Fill Plug**

#### DRIVE LINE MODULE

The drive line module should be inspected for oil leaks and proper oil level when other under vehicle service is performed. To inspect the power transfer unit oil level, position the vehicle on a level surface and remove fill plug (Fig. 7) from the module. The oil level should be at the bottom edge of oil fill opening.

The drive line module does not require periodic maintenance when subjected to normal driving conditions. The oil should be changed when water contami-

nation is suspected. If oil has foamy or milky appearance it probably is contaminated. If the vehicle is subjected to severe driving conditions, the drive line module would require periodic maintenance every 36 000 km (22,500 miles). Refer to Severe Service paragraph in General Information of this group for definition of severe service. For proper diagnostic and service procedures, refer to Group 3, Rear Suspension and Driveline.

#### SELECTING LUBRICANT

Chrysler Corporation recommends Mopar® Gear Lube, SAE 85W-90, or equivalent, be used to fill the drive line module.

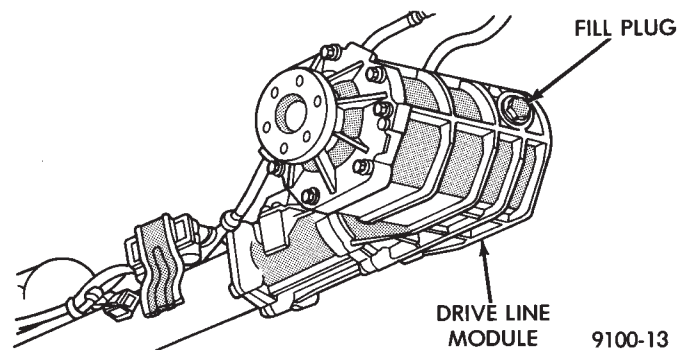

**Fig. 7 Drive Line Module Fill Plug**

#### DRIVE SHAFT CV AND TRIPOD JOINT BOOTS

The front drive shaft constant velocity and tripod joint boots (Fig. 8) should be inspected when other under vehicle service is performed. Inspect boots for cracking, tears, leaks or other defects. If service repair is required, refer to Group 2, Suspension.

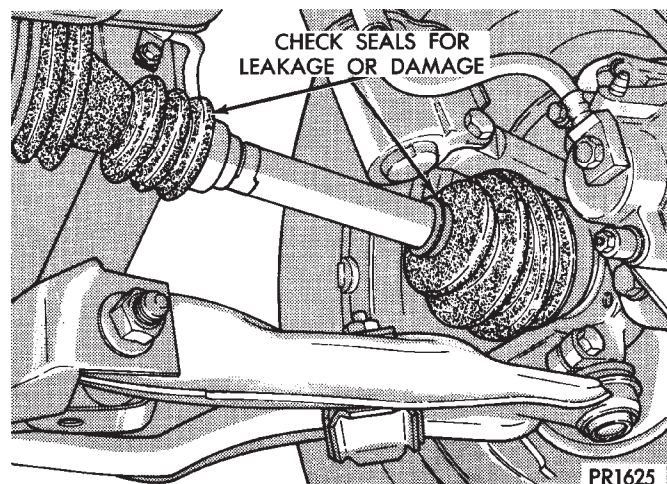

**Fig. 8 Drive Shaft Boots**

#### FRONT WHEEL BEARINGS (REAR WHEEL BEARINGS ON ALL WHEEL DRIVE MODELS)

The front wheel bearings are permanently sealed, requiring no lubrication. For proper diagnostic and service procedures refer to Group 2, Suspension.



**TIRES**

The tires should be inspected at every engine oil change for proper inflation and condition. The tires should be rotated at the distance intervals described in the Lubrication and Maintenance Schedules of the General Information section in this group. For tire inflation specifications refer to the Owner's Manual. A Tire Inflation sticker is located in the driver door opening. For proper diagnostic procedures, see Group 22, Wheels and Tires.

*TIRE ROTATION*

The Forward Cross rotation method is recommended for use on Chrysler Corporation vehicles (Fig. 9). Other rotation methods can be used, but may not have the benefits of the recommended method. Only the four tire rotation method can be used if the vehicle is equipped with a space saver spare tire.

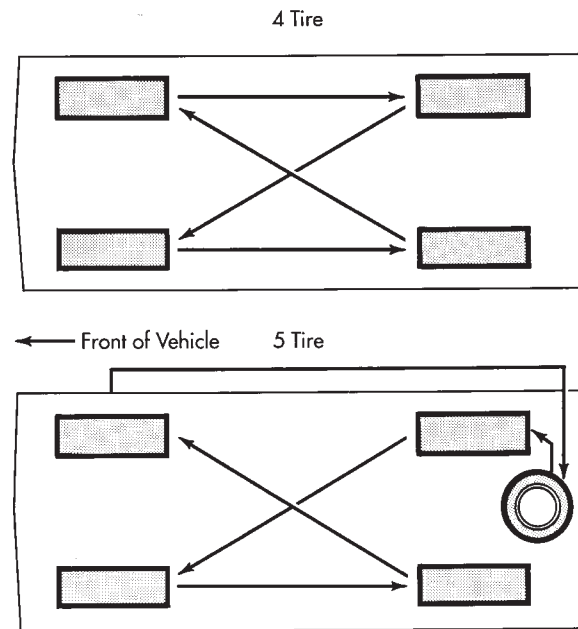

9200-2

**Fig. 9 Tire Rotation**

## CHASSIS AND BODY

### INDEX

	page		page
Body Lubrication .....	22	Lower Ball Joints .....	19
Brakes .....	21	Power Steering .....	19
Driver Supplemental Airbag System .....	22	Rear Wheel Bearings (Front Wheel Drive Only) ...	21
Headlamps .....	22	Steering Linkage .....	19

### STEERING LINKAGE

#### INSPECTION

The steering linkage and steering gear should be inspected for wear, leaks or damage when other under vehicle service is performed. The rack and pinion steering gear end boots should not have excess oil or grease residue on the outside surfaces or surrounding areas (Fig.1). If boot is leaking, it should be repaired. For proper service procedures, see Group 19, Steering.

The tie rod end seal should fit securely between the steering knuckle and tie rod end (Fig.2). The steering linkage should be lubricated at the time and distance intervals described in the Lubrication and Maintenance Schedules. Refer to General Information section of this group.

#### TIE ROD END LUBRICATION

Lubricate the steering linkage with Mopar® Multi-mileage Lube or equivalent. Using a wiping cloth, clean grease and dirt from around grease fitting and joint seal. Using a grease gun, fill tie rod end until lubricant leaks from around the tie rod end side of the seal (Fig.2). When lube operation is complete, wipe off excess grease.

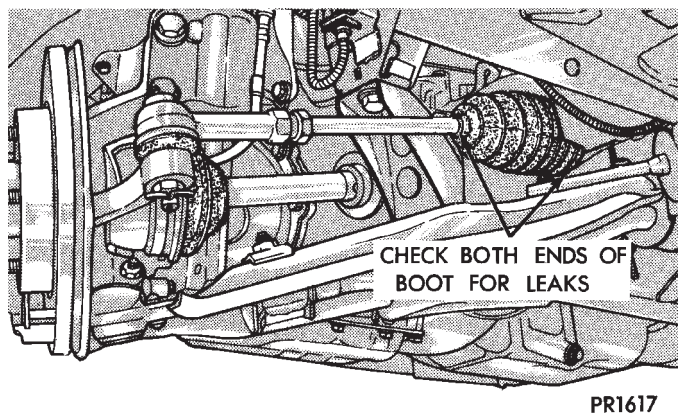

Fig. 1 Inspect Steering Linkage

### LOWER BALL JOINTS

#### INSPECTION

The front suspension lower ball joints should be inspected for wear, leaks or damage when other under

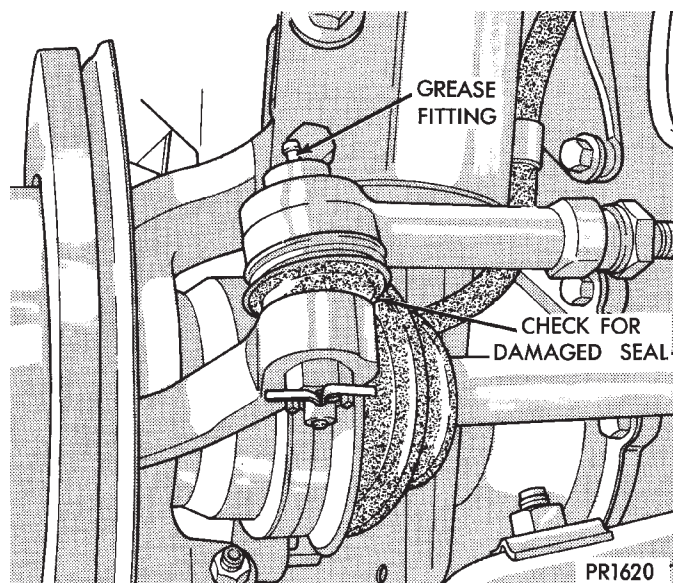

Fig. 2 Tie Rod End Lubrication

vehicle service is performed. The ball joint seal should fit securely between the steering knuckle and lower control arm (Fig. 3). The ball joints should be lubricated at the time and distance intervals described in the Lubrication and Maintenance Schedules. Refer to the General Information section of this group.

#### BALL JOINT LUBRICATION

**CAUTION:** Do not over fill ball joint with grease, damage to seal can result.

Lubricate the ball joints with Mopar® Multi-mileage Lube or equivalent. Using a wiping cloth, clean grease and dirt from around grease fitting and joint seal. Using a grease gun, fill ball joint until seal starts to swell (Fig. 3). When lube operation is complete, wipe off excess grease.

### POWER STEERING

The power steering fluid level should be inspected when other under hood service is performed. If the fluid level is low and system is not leaking, use Mopar®, Power Steering Fluid or equivalent. The power steering system should be inspected for leaks when



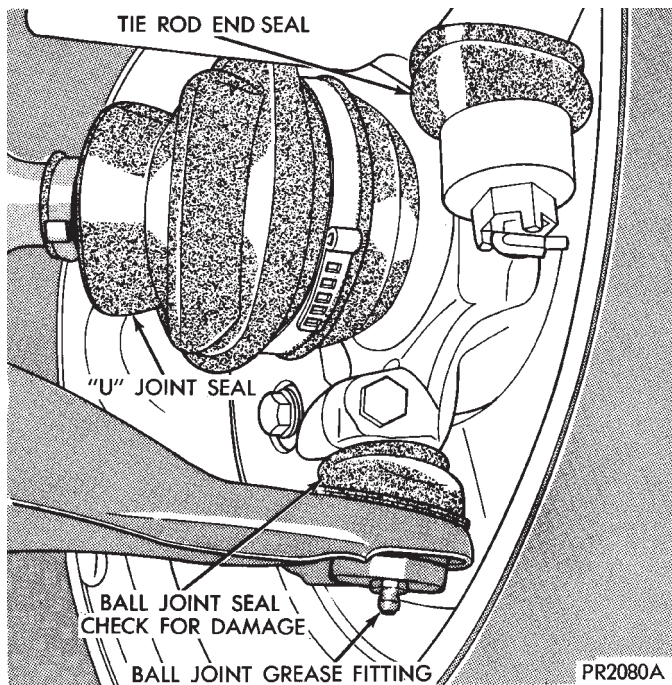

**Fig. 3 Ball Joint Lubrication**

other under vehicle service is performed. For proper service procedures, refer to Group 19, Steering.

The power steering pump drive belt should be inspected at the time and distance interval described in the Lubrication and Maintenance Schedules. Refer to the General Information section of this group.

**POWER STEERING FLUID INSPECTION**

**WARNING: ENGINE MUST NOT BE RUNNING WHEN INSPECTING POWER STEERING FLUID LEVEL, PERSONAL INJURY CAN RESULT.**

**CAUTION: Do not over fill power steering reservoir when adding fluid, seal damage and leakage can result.**

**TO INSPECT FLUID LEVEL:**

- (1) Position vehicle on a level surface with engine at normal running temperature.
- (2) Turn OFF engine and remove ignition key.
- (3) Using a wiping cloth, clean oil and dirt residue from around power steering reservoir cap.
- (4) Remove reservoir cap or dipstick and wipe off fluid.
- (5) Install cap or dipstick.
- (6) Remove cap or dipstick. Holding handle or cap above tip of dipstick, read fluid level (Fig. 4, 5, or 6). Add fluid if reading is below cold level mark on dipstick.

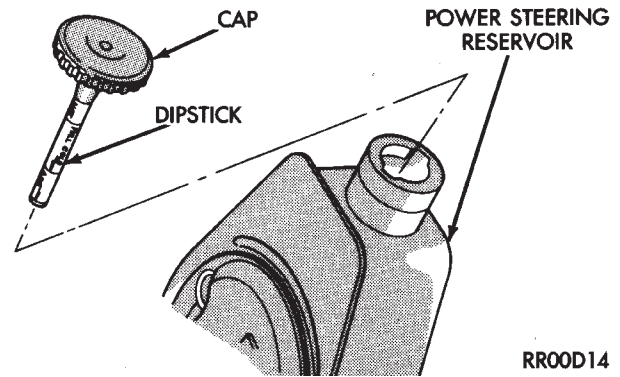

**Fig. 4 Power Steering Reservoir Dipstick—2.5L Engine**

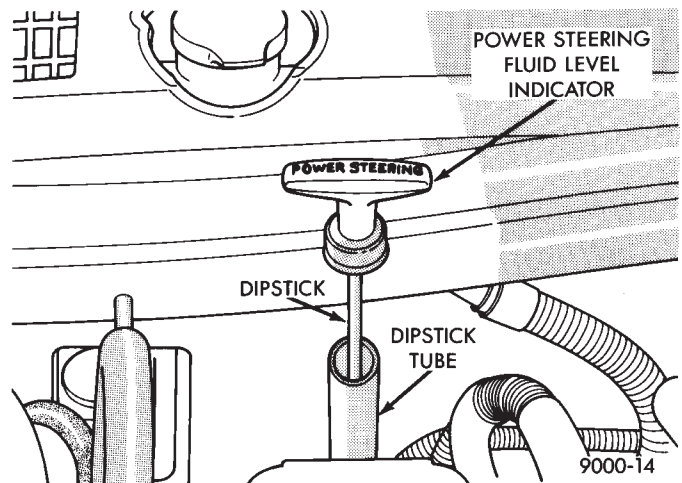

**Fig. 5 Power Steering Reservoir Dipstick—3.0L Engine**

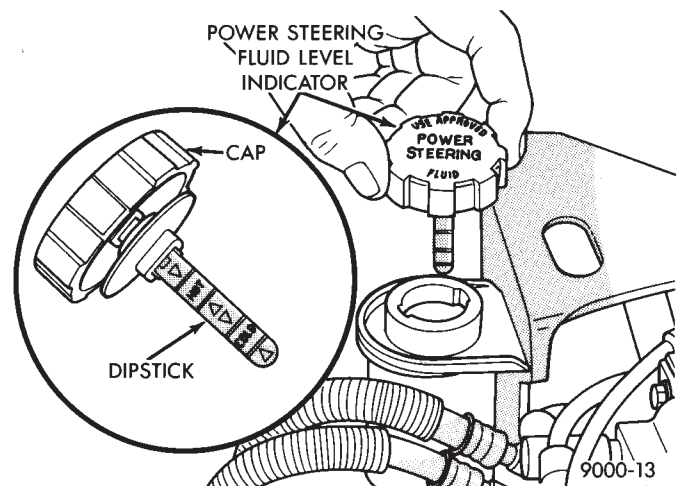

**Fig. 6 Power Steering Reservoir Dipstick—3.3L Engine**



## REAR WHEEL BEARINGS (FRONT WHEEL DRIVE ONLY)

### INSPECTION

The rear wheel bearings should be packed with new lubricant at the distance interval described in the Lubrication and Maintenance Schedules. Refer to the General Information section of this group. The bearings should be inspected for contamination and wear before they are cleaned. Slight discoloration of bearing rollers and race cup is normal. If metal flakes are visible in the used lubricant or the bearing rollers and race cup is discolored, the bearing and race cup should be replaced. For proper service procedures, see Group 5, Brakes. Replace the inner seal whenever the wheel bearings are serviced.

### REAR WHEEL BEARING LUBRICATION

**CAUTION:** Combining two types of lubricant can cause bearing failure. Wash used or new bearings with a suitable solvent and blot dry with a lint free cloth before packing with new lubricant.

**WARNING:** DO NOT ALLOW BEARING TO SPIN AT HIGH RPM WHEN USING COMPRESSED AIR TO BLOW CLEANING SOLVENT FROM BEARING. BEARING CAGE CAN EXPLODE, CAUSING PERSONAL INJURY.

### TO LUBRICATE REAR WHEEL BEARINGS:

(1) Hoist rear wheels off the ground and support vehicle on safety stands. Refer to Hoisting Recommendations in the General Information section of this group.

(2) Remove rear wheels.

(3) Remove brake caliper on vehicles with rear disc brakes. For proper procedure, see Group 5, Brakes.

(4) Remove rear wheel hub (drum) assembly and remove inner grease seal (Fig. 7). For proper service procedure, see Group 5, Brakes.

(5) Inspect bearings, refer to Inspection paragraph of this procedure. Wash used lubricant from bearings with solvent and blot or blow dry.

(6) Using a bearing packing device, lubricate the bearings with Mopar®, Wheel Bearing Grease or equivalent.

(7) With a wiping cloth, clean used lubricant from wheel hub assembly and axle spindle.

(8) Install inner wheel bearing in the hub assembly, small end of bearing toward hub. With a finger, smooth out grease around the outside of bearing.

(9) Using a seal driver, install new inner hub seal.

(10) Install wheel hub (drum) assembly on axle spindle.

(11) Install outer wheel bearing over the spindle end, small end of bearing toward hub. With a finger, smooth out grease around the outside of bearing.

(12) Install washer and spindle nut. While rotating hub, tighten spindle nut to 27 to 34 N·m (240 to 300 in. lbs.) torque. Loosen spindle nut one quarter turn. Hand tighten spindle nut.

(13) Install spindle nut lock cover, cotter pin and grease cap.

(14) Install disc brake caliper on vehicles with disc brakes.

**CAUTION:** Pump brake pedal several times before driving vehicle to verify brake operation.

(15) Install wheel and lower vehicle.

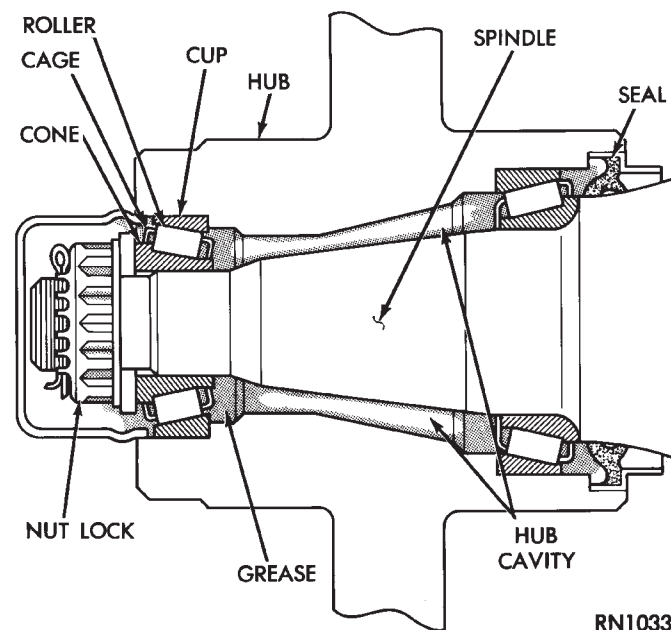

**Fig. 7 Rear Wheel Bearings**

## BRAKES

### BRAKE PAD AND LINING INSPECTION

The brake pads and linings should be inspected at distance intervals described in the Lubrication and Maintenance Schedules. Refer to the General Information section of this group. If brake pads or linings appear excessively worn, the brakes would require service. For proper service procedures, refer to Group 5, Brakes.

### BRAKE HOSE INSPECTION

**WARNING:** IF FRONT WHEEL, REAR AXLE, OR ANTI-LOCK UNIT BRAKE HOSE OUTER COVER IS CRACKED, CHAFED, OR BULGED, REPLACE HOSE IMMEDIATELY. BRAKE FAILURE CAN RESULT.

The front wheel, rear axle and anti-lock unit (if equipped) brake hoses should be inspected at time

and distance intervals described in the Lubrication and Maintenance Schedules. Refer to the General Information section of this group. A hose must be replaced if it has signs of cracking, chafing, fatigue or bulging. For proper service procedures, refer to Group 5, Brakes.

#### BRAKE LINE INSPECTION

The metal brake lines should be inspected when other under vehicle service is preformed. If a line is pinched, kinked, or corroded, it should be repaired. For proper service procedures, refer to Group 5, Brakes.

#### BRAKE RESERVOIR LEVEL INSPECTION

**WARNING: DO NOT ALLOW PETROLEUM OR WATER BASE LIQUIDS TO CONTAMINATE BRAKE FLUID, SEAL DAMAGE AND BRAKE FAILURE CAN RESULT.**

**RELIEVE PRESSURE IN ANTI-LOCK BRAKE SYSTEM BEFORE ADDING BRAKE FLUID TO RESERVOIR. IF NOT, BRAKE FLUID COULD DISCHARGED FROM THE RESERVOIR POSSIBLY CAUSING PERSONAL INJURY.**

The brake reservoir level should be inspected when other under hood service is performed. It is normal for the reservoir level to drop as disc brake pads wear. When fluid must be added, use Mopar®, Brake Fluid or equivalent. Use only brake fluid conforming to DOT 3, Federal, Department of Transportation specification. To avoid brake fluid contamination, use fluid from a properly sealed container.

On vehicles with anti-lock brakes, depressurize the system before inspecting fluid level. Turn OFF the ignition and remove the key. Pump the brake pedal at least 50 times to relieve the pressure in the system.

On all vehicles, if fluid should become low after several thousand kilometers (miles), fill the reservoir to level marks on the side of the reservoir (Fig. 8 or 9).

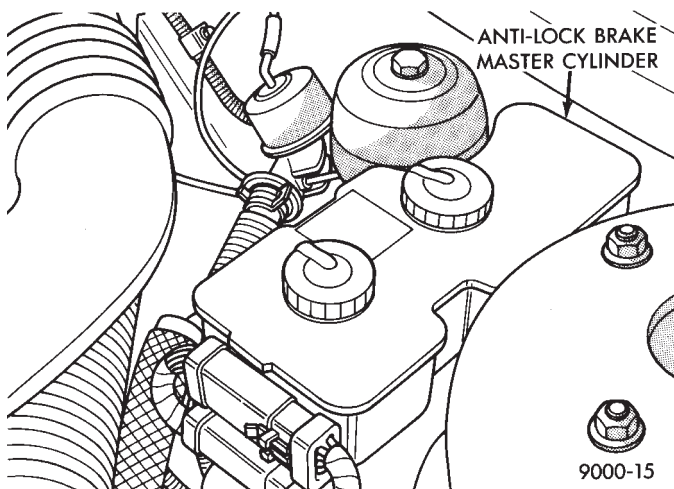

Fig. 8 Anti-lock Brake Reservoir

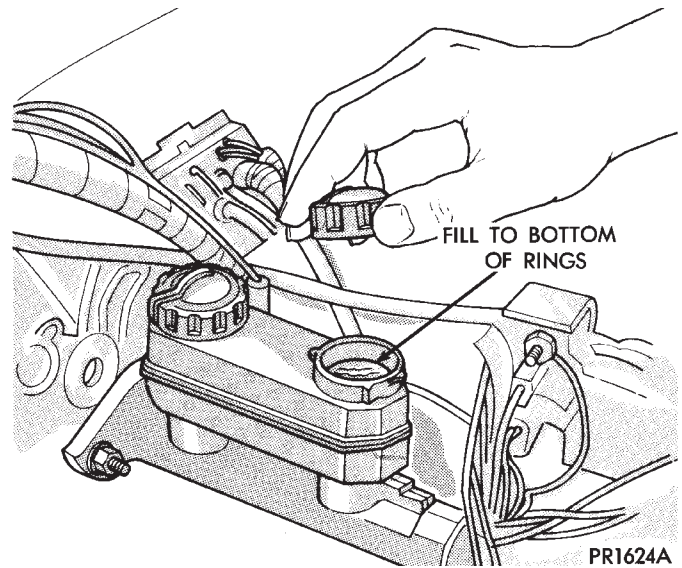

Fig. 9 Master Cylinder Brake Reservoir—Except Anti-lock

#### HEADLAMPS

The headlamps should be inspected for intensity and aim whenever a problem is suspected. When luggage compartment is heavily loaded, the headlamp aim should be adjusted to compensate for vehicle height change. For proper service procedures, refer to Group 8L, Lamps.

#### DRIVER SUPPLEMENTAL AIRBAG SYSTEM

**WARNING: FAILURE TO HAVE THE AIRBAG SYSTEM PROMPTLY SERVICED BY AN AUTHORIZED DEALER SHOULD ONE OF THE FOLLOWING CONDITIONS EXIST CAN LEAD TO POSSIBLE INJURY IN THE EVENT OF AN ACCIDENT.**

If the AIRBAG indicator lamp does not light at all, stays lit or lights momentarily or continuously while driving, a malfunction may have occurred. Prompt service is required. Refer to Group 8M, Restraint Systems for proper diagnostic procedures.

The airbag system and components should be inspected and tested for electronic diagnostic fault codes at the intervals described in the Lubrication and Maintenance Schedules in the Introduction section of this group.

#### BODY LUBRICATION

Body mechanisms and linkages should be inspected, cleaned and lubricated as required to maintain ease of operation and to prevent corrosion and wear.

Before a component is lubricated, oil, grease and dirt should be wiped off. If necessary, use solvent to clean component to be lubricated. After lubrication is

complete, wipe off excess grease or oil.

During winter season, external lock cylinders should be lubricated with Mopar®, Lock Lubricant or equivalent to assure proper operation when exposed to water and ice.

To assure proper hood latching component operation, use engine oil to lubricate the latch, safety catch and hood hinges when other under hood service is performed. Mopar®, Multi-purpose Grease or equivalent should be applied sparingly to all pivot and slide contact areas.

#### USE ENGINE OIL ON

- Door hinges—Hinge pin and pivot points.
- Hood hinges—Pivot points.
- Liftgate hinges—Pivot points.
- Sliding door center hinge pivot.

#### USE MOPAR® LUBRIPLATE OR EQUIVALENT ON

- Door check straps.
- Liftgate latches.
- Liftgate prop rod pivots.
- Ash tray slides.
- Fuel Fill Door latch mechanism.
- Park brake mechanism.
- Front seat tracks.
- Sliding door rear latch striker.
- sliding door closure wedges

#### USE MOPAR® MULTI-PURPOSE GREASE OR EQUIVALENT ON

- Sliding door center track.
- Sliding door upper track.
- Sliding door open position striker spring.

