

BRAKES

CONTENTS

	page		page
ANTI-LOCK BRAKE SYSTEM (BENDIX ANTI-LOCK 10 AS BODY FWD/AWD)	56	CALIPER	35
BRAKE DISC (ROTOR)	42	MASTER CYLINDER	49
BRAKES	20	PARKING BRAKES	46
BRAKE DIAGNOSIS	15	POWER BRAKES	51
DISC BRAKES	33	SERVICE ADJUSTMENTS	3
GENERAL INFORMATION	1	SERVICE PROCEDURES	31
HYDRAULIC SYSTEM CONTROL VALVES	28	SPECIFICATIONS	90
KELSEY HAYES DOUBLE PIN FAMILY		WHEEL BEARINGS	54
		WHEEL CYLINDERS	26

GENERAL INFORMATION

Throughout this group, references may be made to a particular vehicle by letter or number designation. A chart showing the breakdown of these designations is included in the Introduction Section at the front of this service manual.

Standard brake equipment consists of:

- Double pin floating caliper disc front brakes.
- Rear automatic adjusting drum brakes.
- Differential valve with a brake warning switch.
- Master cylinder.

- Height sensing proportioning valve.
- Vacuum power booster.

Front brake shoes have semi metallic linings. The brake system (Fig. 1 and 2) is diagonally split on both the Non-ABS and ABS braking system. With the left front and right rear brakes on one hydraulic system and the right front and left rear on the other.

The master cylinder is anodized, lightweight aluminum. It has a bore diameter of 24.0 mm.

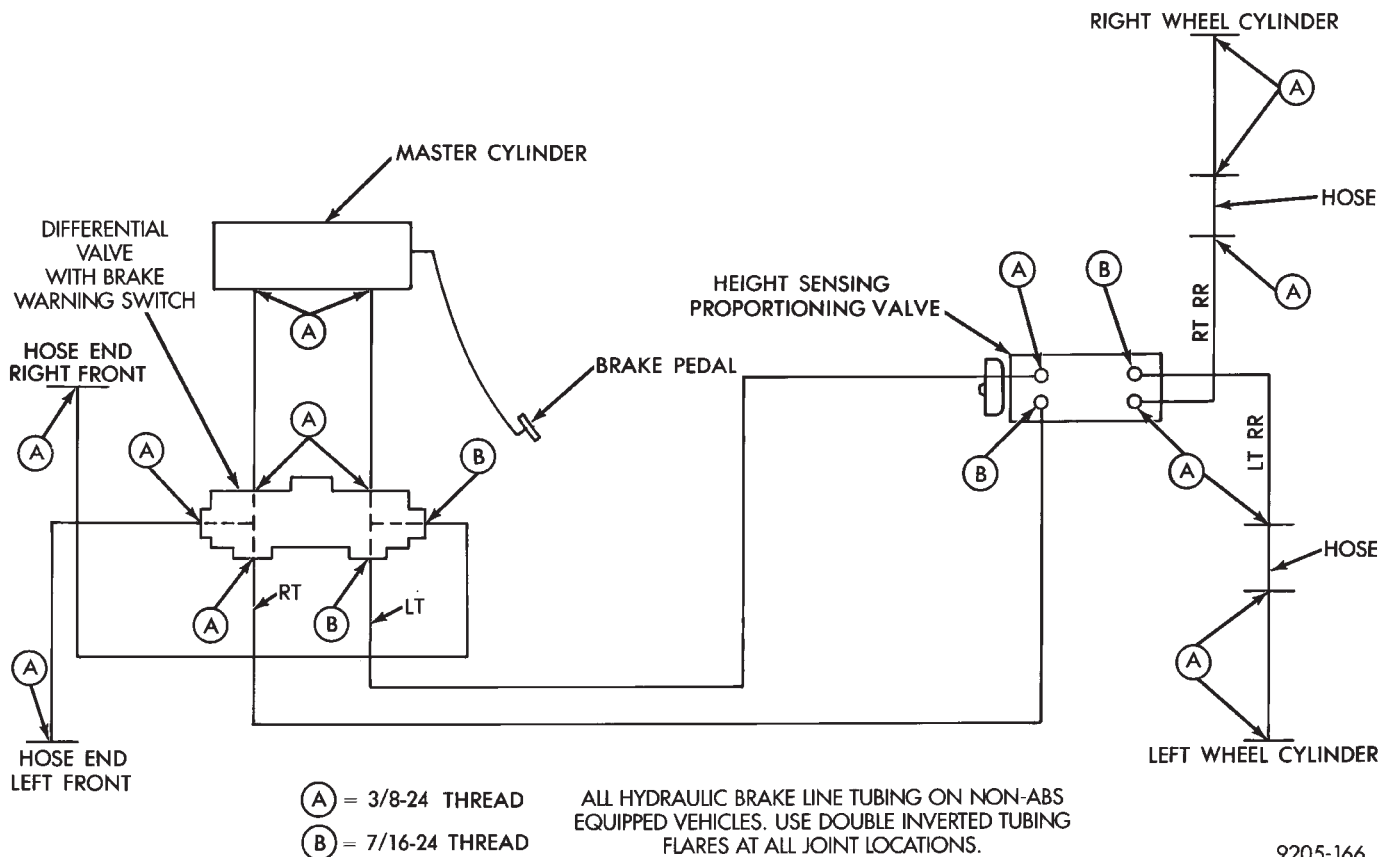
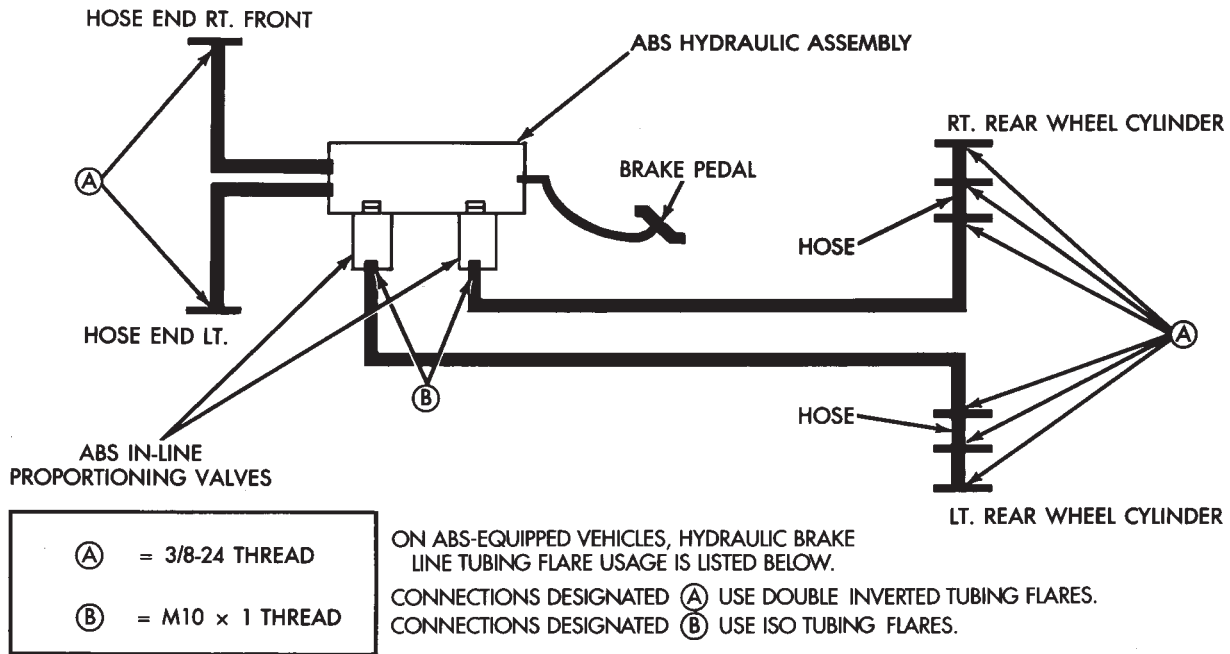

Fig. 1 Proper Nut Thread Size and Tube Routing (Non-ABS Equipped Vehicles)



9205-167

Fig. 2 Proper Nut Thread Size and Tube Routing (ABS-Equipped Vehicles)

SERVICE ADJUSTMENTS

INDEX

	page		page
Adjusting Rear Service Brakes	3	Stop Lamp Switch Adjustment	9
Bleeding Brake System	5	Test for Fluid Contamination	7
Brake Hose and Tubing	7	Testing Application Adjuster Operation	10
Master Cylinder Fluid Level	4	Wheel Stud Nut Tightening	7

ADJUSTING REAR SERVICE BRAKES

Normally, self adjusting drum brakes will not require manual brake shoe adjustment. Although in the event of a brake reline it is advisable to make the initial adjustment manually to speed up the adjusting time.

FRONT WHEEL DRIVE

(1) Raise the vehicle so all wheels are free to turn. See Hoisting Recommendations in the Lubrication And Maintenance Section, at the front of this service manual.

(2) Remove rear brake adjusting hole rubber plug

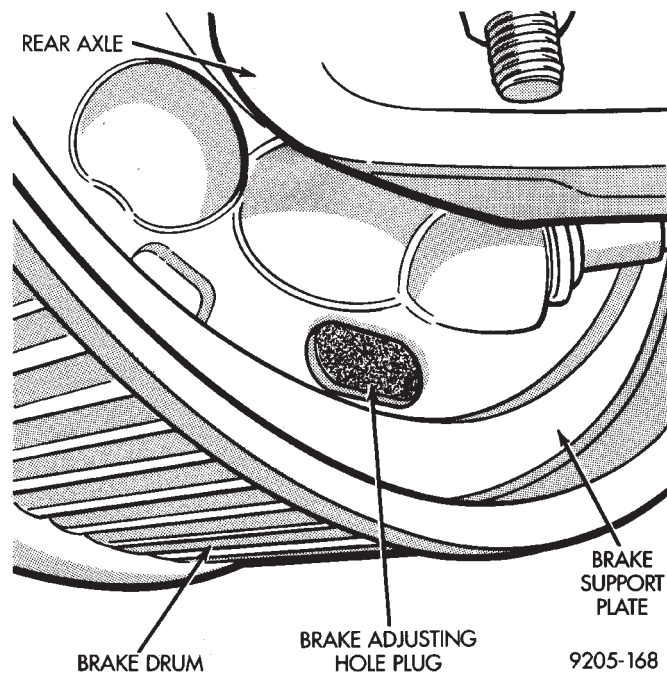

Fig. 1 Brake Adjusting Hole Plug

(Fig. 1), from the rear brake shoe support plate.

(3) **Be sure parking brake lever is fully released. Then back off parking brake cable adjustment so there is slack in the cable.**

(4) Insert Brake Adjusting, Special Tool C-3784, (Fig. 2) or equivalent through the adjusting hole in support plate and against star wheel of adjusting screw. Move handle of tool upward until a slight drag is felt when road wheel is rotated.

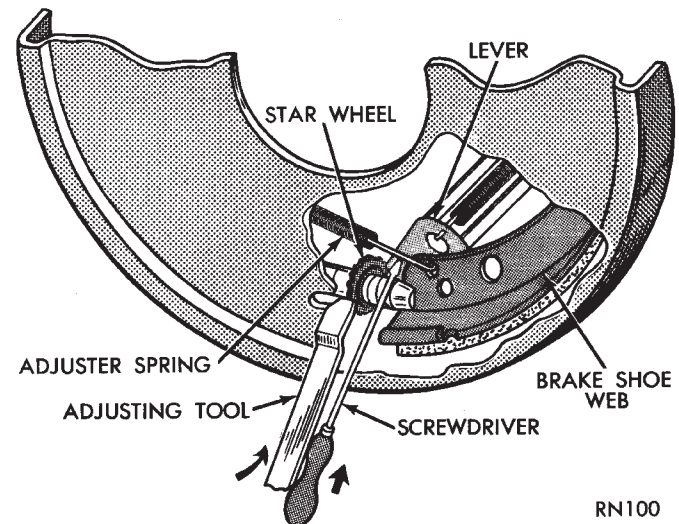

Fig. 2 Brake Drum Adjustment With Tool C-3784

(5) Insert a thin screwdriver or piece of welding rod into brake adjusting hole (Fig. 2). Push adjusting lever out of engagement with star wheel. **Care should be taken so as not to bend adjusting lever or distort lever spring.** While holding adjusting lever out of engagement, back off star wheel to ensure a free wheel with no brake shoe drag.

(6) Repeat above adjustment at the other rear wheel. Install adjusting hole rubber plugs (Fig. 1) in rear brake supports.

(7) Adjust parking brake **after** wheel brake adjustment.

It is important to follow the above sequence to avoid the possibility of the parking brake system causing brake drag. This could occur if the parking brakes are adjusted before the service brakes.

ALL WHEEL DRIVE

(1) Raise the vehicle so all wheels are free to turn. See Hoisting Recommendations in the Lubrication And Maintenance Section, at the front of this service manual.

(2) **Be sure parking brake lever is fully released. Then back off parking brake cable adjustment so there is slack in the cable.**

(3) Remove the rear tire and wheel assembly from the vehicle to expose the front of the rear brake drum.

(4) Rotate the rear brake drum so the adjusting holes in the face of the brake drum are positioned at 12:00 and 6:00 (Fig. 3).

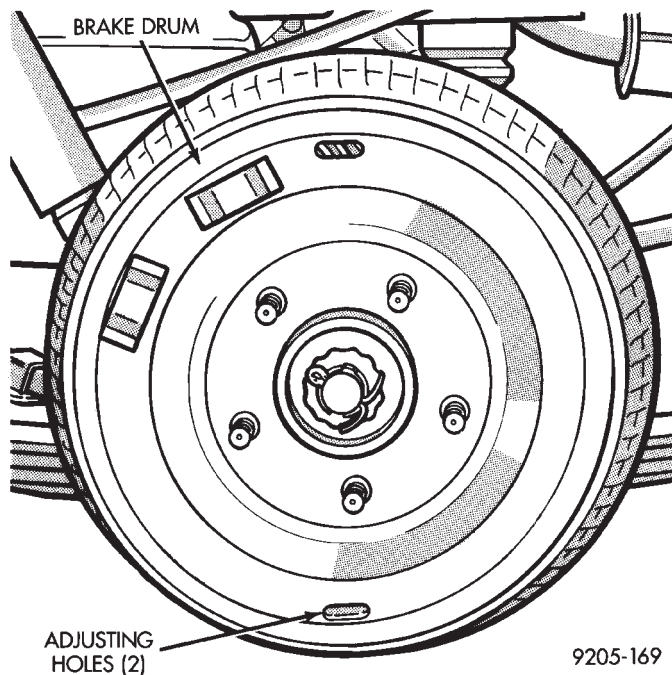

Fig. 3 Rear Brake Drum Position For Parking Brake Adjustment (AWD)

(5) Insert Brake Adjusting, Special Tool C-3784 (Fig. 4) or equivalent through the adjusting hole in brake drum and against star wheel of adjusting screw. Move adjusting tool in a downward motion until a slight drag is felt when brake drum is rotated.

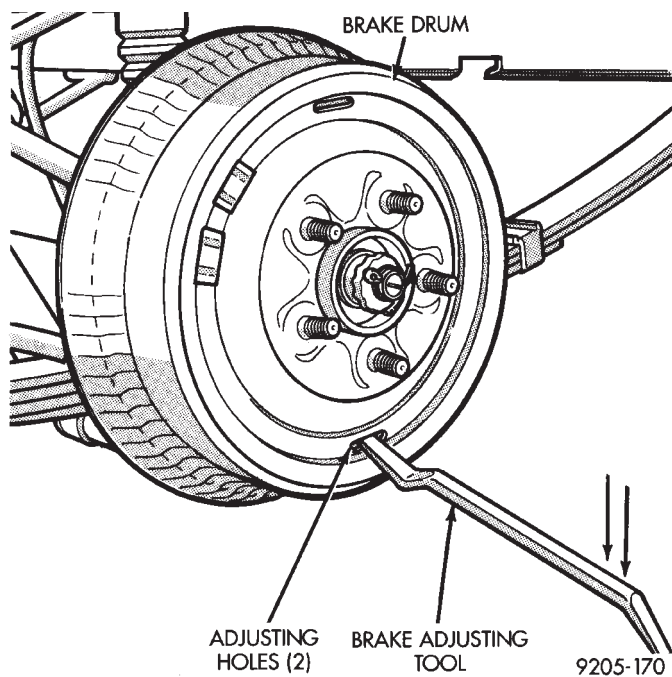

Fig. 4 Brake Shoe Adjustment

(6) Then insert a hooked piece of welding rod through the adjusting hole in brake drum. Hook rod onto adjusting lever and pull lever out of engagement with star wheel. While pulling adjustment lever out of engagement with star wheel, back off star wheel adjuster just until there is no contact between brake shoes and brake drum. **Care must be taken so as not to bend adjusting lever or distort lever spring.**

(7) Repeat above adjustment procedure at the other wheel.

(8) Install the tire and wheel assemblies back on the vehicle. Install the wheel stud nuts and torque to 129 N•m (95 ft. lbs.).

(9) Adjust parking brake **AFTER** wheel brakes are adjusted.

It is important to follow the above sequence to avoid the possibility of the parking brake system causing brake drag. This condition could occur if the parking brakes are adjusted before the service brakes.

MASTER CYLINDER FLUID LEVEL

NON-ABS BRAKES

Check master cylinder reservoir fluid level a minimum of twice annually.

Master cylinder reservoirs are marked with the words fill to bottom of rings indicating proper fluid level (Fig. 5).

If necessary, add fluid to bring the level to the bottom

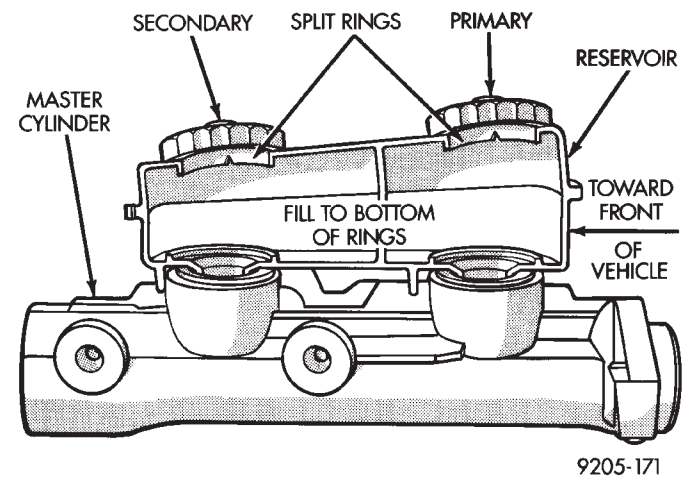

Fig. 5 Master Cylinder Fluid Level (Non-ABS)

of the primary reservoir split ring.

Use only Mopar® brake fluid or an equivalent from a sealed container. Brake fluid must conform to DOT 3, specifications.

DO NOT use brake fluid with a lower boiling point, as brake failure could result during prolonged hard braking.

Use only brake fluid that was stored in a tightly-sealed container.

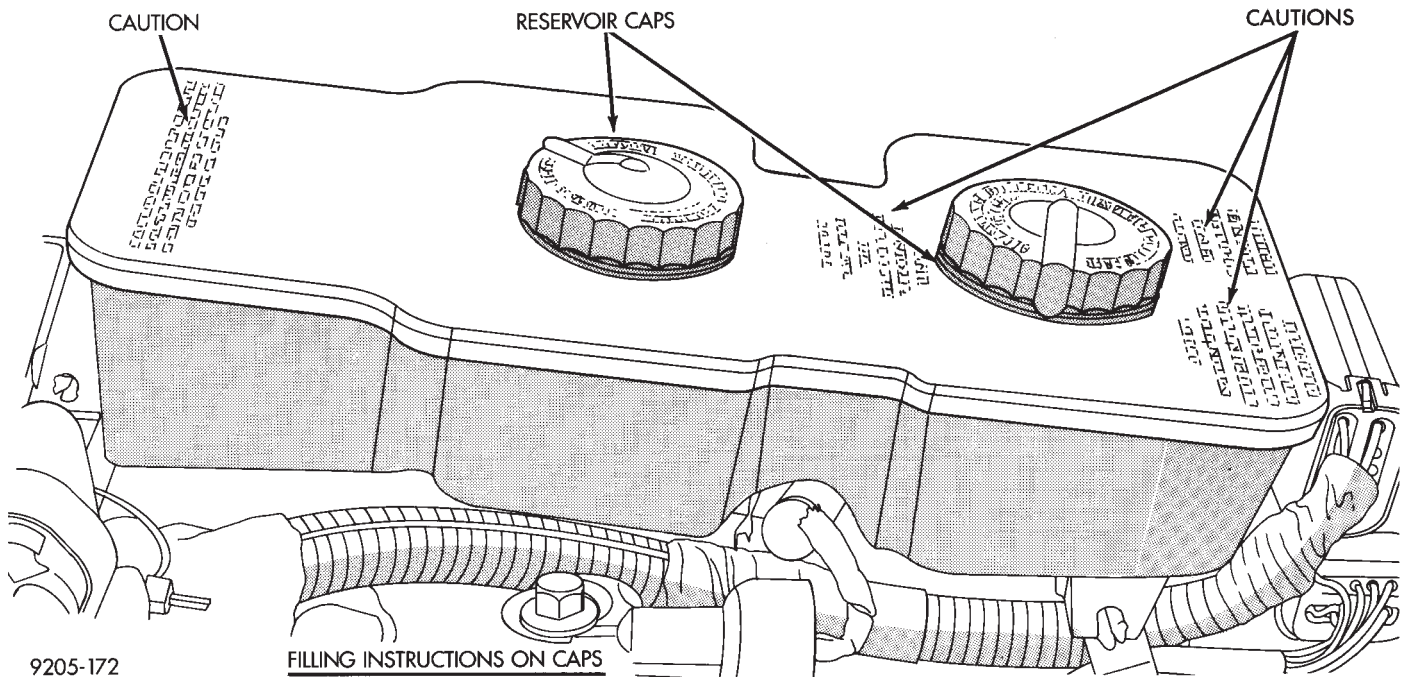

Fig. 6 Master Cylinder Fluid Level (W/ABS)

DO NOT use petroleum-based fluid because seal damage will result.

ABS BRAKES

The hydraulic assembly is equipped with a plastic fluid reservoir with a filter/strainer in the filler neck.

The Anti-Lock brake system requires that the hydraulic accumulator be de-pressurized when checking the fluid level. To check the brake fluid level, the following procedure should be used:

(1) With the ignition off, de-pressurize the hydraulic accumulator by applying the brake pedal approximately 40 times, using a pedal force of approximately 220 N (50 lbs.). A noticeable change in pedal feel will occur when the accumulator is de-pressurized. Continue to apply the pedal several times after this change in pedal feel occurs to insure that the brake system is fully de-pressurized.

(2) Thoroughly clean both reservoir caps and surrounding area, (Fig. 6) before removing caps. This is to avoid getting dirt into the reservoir.

(3) Inspect the fluid level, see instructions on top of reservoir. (TO TOP OF WHITE SCREEN ON FRONT FILTER/STRAINER.)

(4) Fill with brake fluid to top of screen (Fig. 7) on the filter/strainer located in brake fluid reservoir. Use only brake fluid conforming to DOT 3 specifications such as Mopar® or equivalent.

(5) Replace reservoir cap.

BLEEDING BRAKE SYSTEM

PRESSURE BLEEDING

Before removing the master cylinder cover, wipe it clean to prevent dirt and other foreign matter from dropping into the master cylinder.

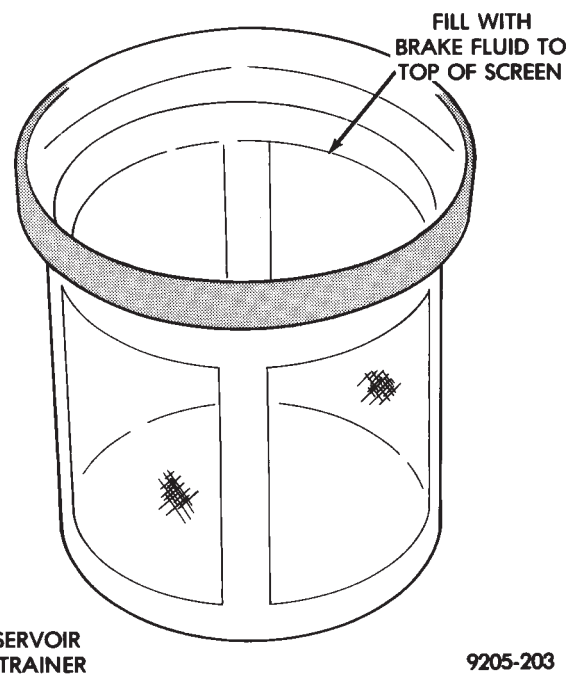

**ABS RESERVOIR
FILTER/STRAINER**

9205-203

Fig. 7 ABS Reservoir Fill Level On Filter/Strainer

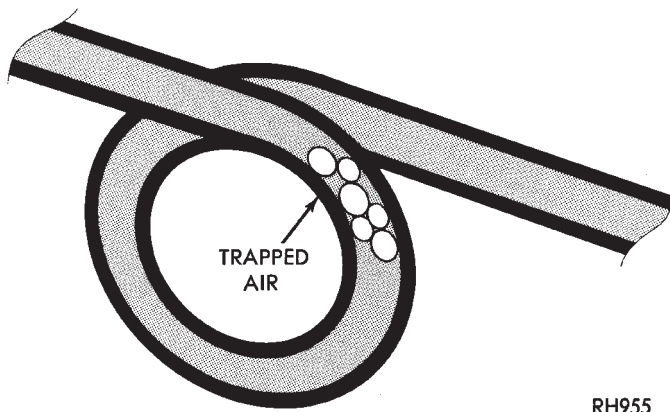

Fig. 8 Trapped Air in Brake Line

RH955

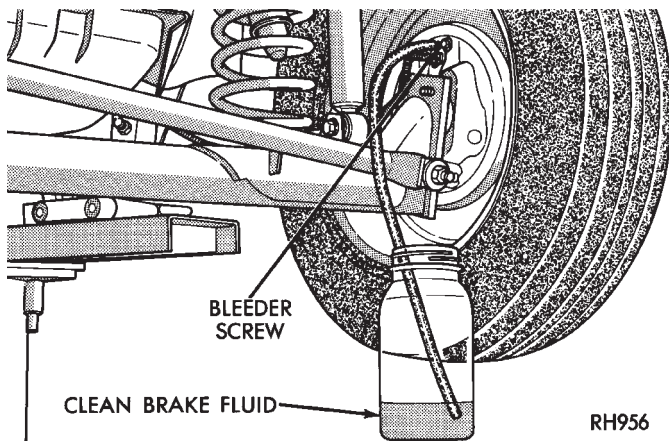

Fig. 9 Proper Method for Purging Air From Brake System (Typical)

RH956

CAUTION: Use bleeder tank Special Tool C-3496-B with adapter Special Tool C-4578 to pressurize the system for bleeding.

Follow pressure bleeder manufacturer's instructions, for use of pressure bleeding equipment.

When bleeding the brake system. Some air may be trapped in the brake lines or valves far upstream. As much as ten feet from the bleeder screw (Fig. 8). Therefore, it is essential to have a fast flow of a large volume of brake fluid when bleeding the brakes to ensure all the air gets out.

To bleed the brake system. Attach a clear plastic hose to the bleeder screw at one wheel and feed the hose into a clear jar containing fresh brake fluid (Fig. 9).

Next, open the bleeder screw at least **one full turn** or more to obtain an adequate flow of brake fluid (Fig. 10).

CAUTION: Just cracking the bleeder screw often restricts fluid flow, and a slow, weak fluid discharge will **NOT** get all the air out.

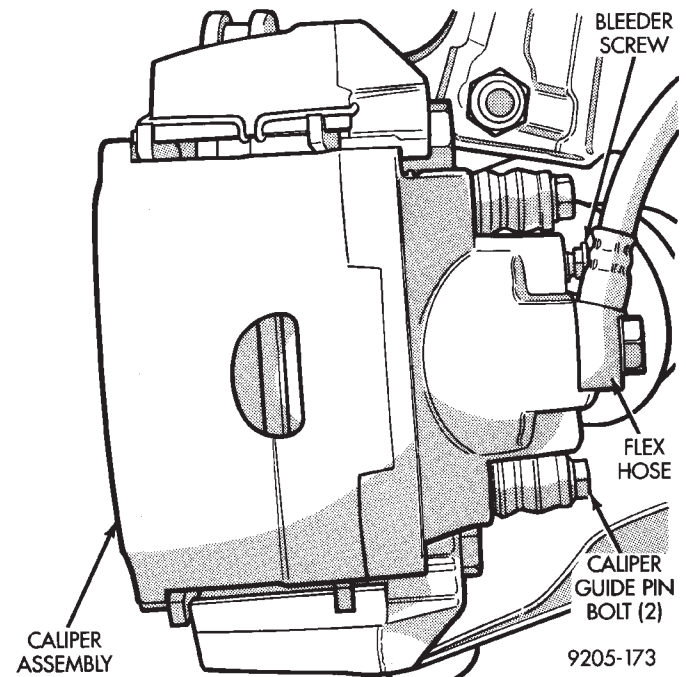

Fig. 10 Open Bleeder Screw at Least One Full Turn (Typical)

After 4 to 8 ounces of fluid has been bled through the brake system. And an air-free flow is maintained in the clear plastic hose and jar, this will indicate a good bleed.

Repeat the procedure at all the other remaining bleeder screws. Then check the pedal for travel. If pedal travel is excessive or has not been improved. Enough fluid has not passed through the system to expel all the trapped air. Be sure to monitor the fluid level in the pressure bleeder, so it stays at a proper level so air will not enter the brake system through the master cylinder.

BLEEDING WITHOUT A PRESSURE BLEEDER

If a pressure bleeder is not available. A good brake fluid flow can be obtained by manual bleeding of the brake hydraulic system, following these steps:

(1) Pump the brake pedal three or four times and hold it down before the bleeder screw is opened.

(2) Push the brake pedal toward the floor and hold it down. Then open the bleeder screw at least 1 full turn. When the bleeder screw opens the brake pedal will drop all the way to the floor.

(3) Release the brake pedal only **after** the bleeder screw is closed.

(4) Repeat steps 1 through 3, four or five times, at each bleeder screw. This should pass a sufficient amount of fluid to expel all the trapped air from the brake system. Be sure to monitor the fluid level in the master cylinder, so it stays at a proper level so air will not enter the brake system through the master cylinder.

Test drive vehicle to be sure brakes are operating correctly and that pedal is solid.

TEST FOR FLUID CONTAMINATION

Indications of fluid contamination are swollen or deteriorated rubber parts.

Swollen rubber parts indicate the presence of petroleum in the brake fluid.

To test for contamination, put a small amount of drained brake fluid in clear glass jar. If fluid separates into layers, there is mineral oil contamination.

If brake fluid is contaminated, drain and thoroughly flush system. Replace master cylinder, proportioning valve, caliper seals, wheel cylinder seals and all hoses.

WHEEL STUD NUT TIGHTENING

When tightening wheel stud nuts, a criss-cross tightening sequence should be followed (Fig. 11).

Tighten all stud nuts to one-half specified torque.

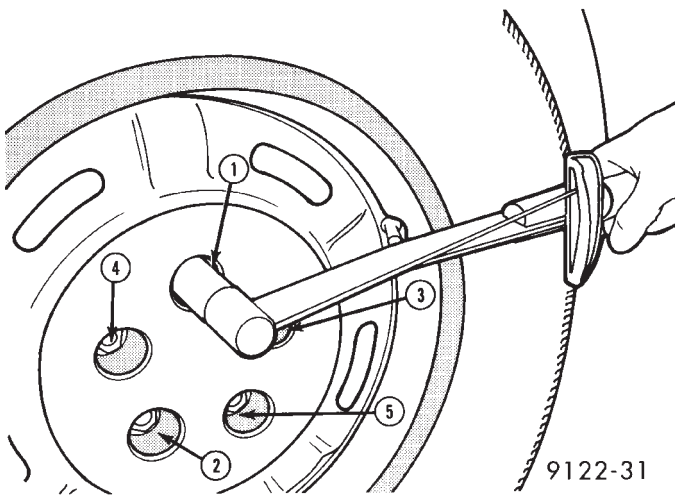

Fig. 11 Wheel Stud Nut Tightening Sequence

Repeat, fully tightening to 129 N•m (95 ft. lbs.).

BRAKE HOSE AND TUBING

INSPECTION OF BRAKE HOSE AND TUBING

Flexible rubber hose is used at both front brakes and at the rear axle. Inspection of brake hoses should be performed whenever the brake system is serviced and every 7,500 miles or 12 months, whichever comes first (every engine oil change). Inspect hydraulic brake hoses for severe surface cracking, scuffing, or worn spots. If the fabric casing of the rubber hose becomes exposed due to cracks or abrasions in the rubber hose cover, the hose should be replaced immediately. Eventual deterioration of the hose can take place with possible burst failure. Faulty installation can cause twisting, and wheel, tire, or chassis interference.

The steel brake tubing should be inspected periodically for evidence of physical damage or contact with moving or hot components.

INSTALLATION OF BRAKE HOSE

Always use factory recommended brake hose to ensure quality, correct length and superior fatigue life. Care should be taken to make sure that the tube and hose mating surfaces are clean and free from nicks and burrs. **Right and left hoses are not interchangeable.**

Use new copper seal washers on all Banjo bolts and tighten all fittings to specified torque. All connections must be torqued to correct specifications and properly made.

The flexible hydraulic brake hose should always be installed on the vehicle by first attaching the Banjo connector to the caliper assembly. Then bolt the intermediate hose bracket to the strut assembly allowing the bracket to position the hose to prevent twisting. Lastly attach the hose to the body bracket and steel brake tubing. Tighten all fittings to specified torque. The body bracket and hose end are keyed so that they will only fit one way.

Install rear brake hoses first to the trailing arm crossmember tubes and then to the floor pan tubes. This procedure should be followed to minimize hose twisting.

TYPES OF TUBING FLARES

Two different tubing flares (Fig. 12) are used on 92 M.Y. vehicles. On all ABS brake systems the tubing connections made to the hydraulic assembly use an ISO flare. All other ABS brake system component, tubing connections are made using a double inverted flare. On non-ABS brake systems all component tubing connections use only the double inverted flare. No ISO flares are used.

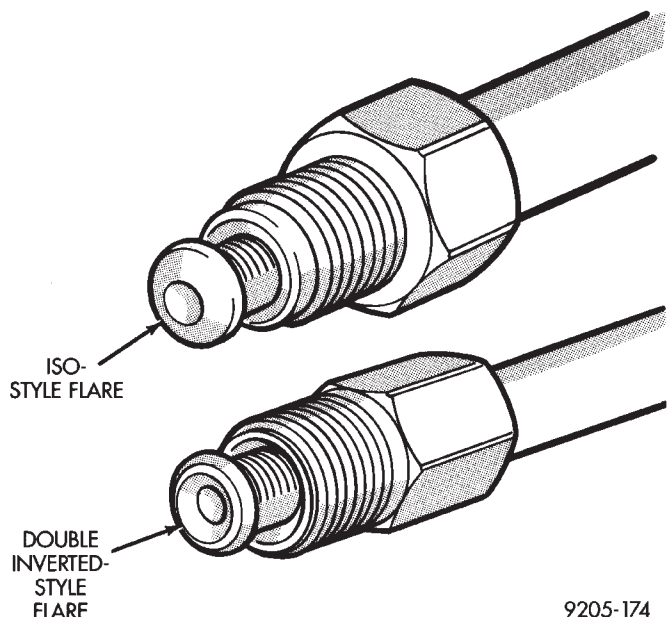

9205-174

Fig. 12 Hydraulic Brake Tubing Flares



REPAIR AND INSTALLATION OF BRAKE TUBING

Only double wall 4.75mm (3/16 in.) steel tubing should be used for replacement. Care should be taken when replacing brake tubing, to be sure the proper bending and flaring tools and procedures are used, to avoid kinking. Do not route the tubes against sharp edges, moving components or into hot areas. All tubes should be properly attached with recommended retaining clips.

TO REPAIR OR FLARE TUBING

CAUTION: ALWAYS USE THE PROPER FLARING TOOL AND PROCEDURE, FOR THE TYPE OF BRAKE SYSTEM THAT IS BEING SERVICED TO INSURE THE INTEGRITY OF THE HYDRAULIC SYSTEM.

Using Tubing Cutter, Special Tool C-3478-A or equivalent, cut off damaged seat or tubing (Fig. 13). Ream out any burrs or rough edges showing on inside of tubing (Fig. 14). This will make the ends of tubing square (Fig. 14) and ensure better seating of flared end tubing. **PLACE TUBE NUT ON TUBING BEFORE FLARING THE TUBING.**

DOUBLE INVERTED TUBING FLARES.

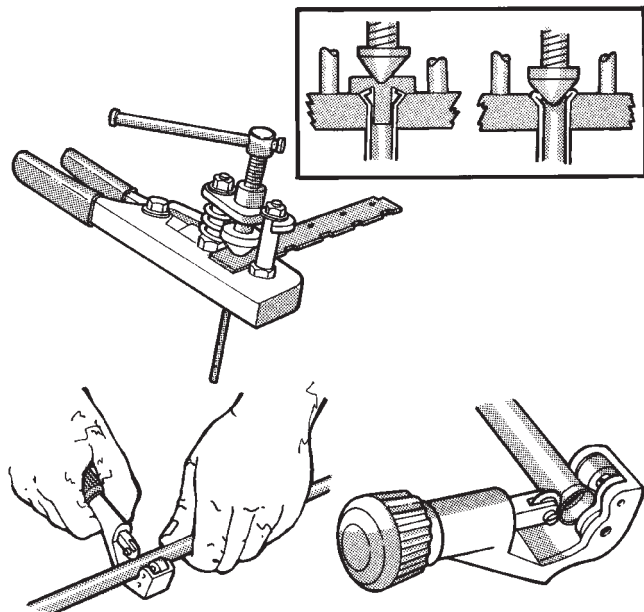

RH222

Fig. 13 Cutting and Flaring of Brake Line Tubing

To make a double inverted tubing flare (Fig. 12 & 15). Open handles of Flaring Tool, Special Tool C-4047 or equivalent. Then rotate jaws of tool until the mating jaws of tubing size are centered between vertical posts on tool. Slowly close handles with tubing inserted in jaws but do not apply heavy pressure to handle as this will lock tubing in place.

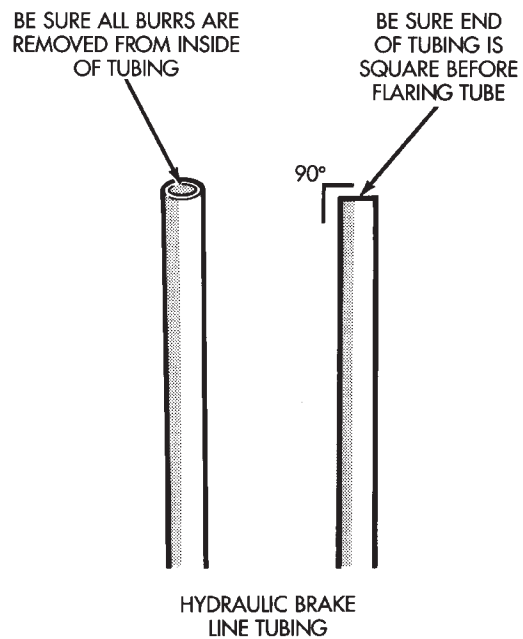

9205-175

Fig. 14 Brake Tube Preparation For Flaring

Place gauge (Form A) on edge over end of brake tubing. Push tubing through jaws until end of tubing contacts the recessed notch in gauge matching the tubing size. Squeeze handles of flaring tool and lock tubing in place. Place 3/16 inch plug of gauge (A) down in end of tubing. Swing compression disc over gauge and center tapered flaring screw in recess of disc. Screw in until plug gauge has seated on jaws of flaring tool. This action has started to invert the ex-

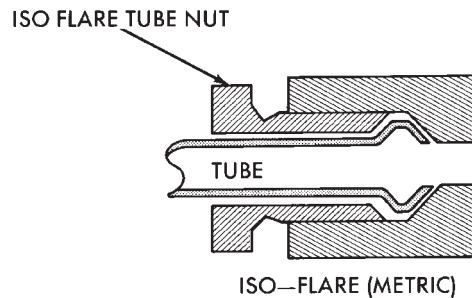
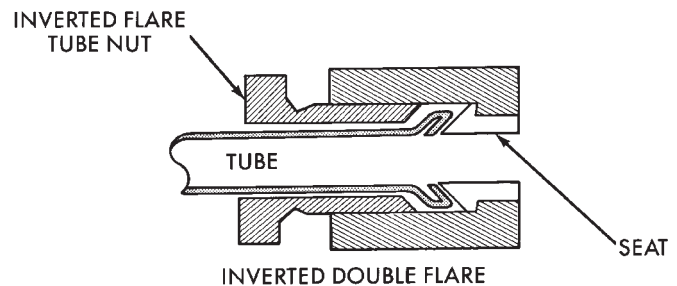

9105-30

Fig. 15 Double Flare And ISO-Flare Tubing Connections

tended end of the tubing. Remove gauge and continue to screw down until tool is firmly seated in tubing. Remove tubing from flaring tool and inspect seat. Refer to routing diagrams (Figs. 18 to 21) for proper routing and clip location. Replace any damaged tube routing clips.

ISO TUBING FLARES

CAUTION: All ISO style tubing flares (Fig. 12 & 15) are of metric dimensions. When performing any service procedures on vehicles using ISO style tubing flares, metric size tubing of 4.75 mm MUST be used with metric ISO tube flaring equipment.

To create a (metric) ISO style tubing flare, Use Snap-On Flaring Tool TFM-428, or equivalent. See (Fig. 16) and proceed with the steps listed below. **Be sure to place the tubing nut on the tube before flaring the tubing.**

(1) Carefully prepare the end of the tubing to be flared. Be sure the end of the tubing to be flared is square and all burrs on the inside of the tubing are removed (Fig. 14). **This preparation is essential to obtain the correct form of a (metric) ISO tubing flare.**

(2) Open the jaws of the Flaring Tool. Align the mating size jaws of the flaring tool around the size of the tubing to be flared. Close the jaws of the Flaring Tool around the tubing to keep it from sliding out of the flaring tool, but do not lock the tubing in place. See (Fig. 16)

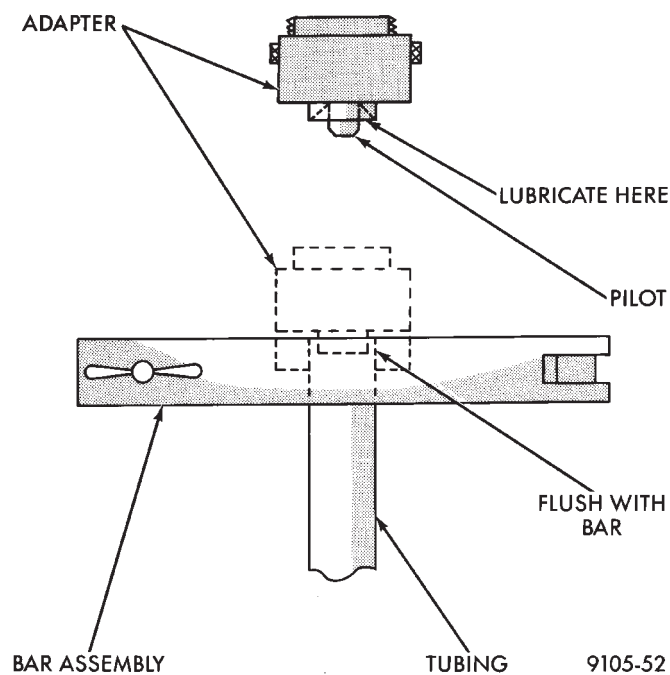

Fig. 16 ISO Tubing Flare Process

(3) Position the tubing in the jaws of the Flaring Tool so that it is flush with the top surface of the flaring tool bar assembly. (See Fig. 16)

(4) Install the correct size adaptor for the brake tubing being flared, on the feed screw of the yoke assembly. Center the yoke and adapter over the end of the tubing. Apply lubricant to the adapter area that contacts brake tubing. Making sure the adapter pilot is fully inserted in the end of the brake tubing. Screw in the feed screw of the yoke assembly until the adaptor has seated squarely on the surface of the bar assembly (Fig. 16). This process has created the (metric) ISO tubing flare.

STOP LAMP SWITCH ADJUSTMENT

The stop lamp switch incorporates a self adjusting feature. If adjustment or replacement is required, proceed as follows: Install the switch in the retaining bracket and push the switch forward as far as it will go. The brake pedal will move forward slightly (Fig. 17). Gently pull back on the brake pedal bringing the striker back toward the switch until the brake pedal will go back no further. This will cause the switch to ratchet backward to the correct position. Very little movement is required, and no further adjustment is necessary.

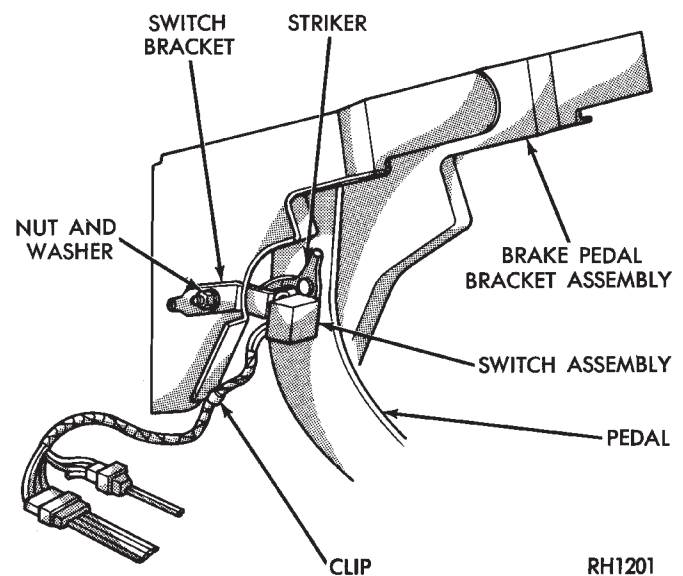

Fig. 17 Stop Lamp Switch

TESTING APPLICATION ADJUSTER OPERATION

Place the vehicle on a hoist with a helper in the driver's seat to apply the brakes. Remove the access plug from the rear adjustment slot in each brake support plate (Fig. 1) to provide access to the adjuster star wheel. Then, to eliminate the possibility of maximum adjustment, where the adjuster does not operate because the closest possible adjustment has been reached. Back the star wheel off approximately 30 notches. It will be necessary to hold the adjuster lever away from the star wheel to permit this adjustment.

Spin the wheel and brake drum in the reverse direction and with a greater than normal force apply

the brakes suddenly. This sudden application of force will cause the secondary brake shoe to leave the anchor. The wrap up effect will move the secondary shoe, and the cable will pull the adjuster lever up. Upon application of the brake pedal, the lever should move upward, turning the star wheel. Thus, a definite rotation of the adjuster star wheel can be observed if the automatic adjuster is working properly. If one or more adjusters do not function properly, the respective drum must be removed for adjuster servicing.



LET	TIGHTENING TORQUE
A	30 IN. LBS. 3 N•m
B	70 IN. LBS. 8 N•m
C	95 IN. LBS. 11 N•m
D	105 IN. LBS. 12 N•m
E	145 IN. LBS. 16 N•m
F	24 FT. LBS. 18 N•m

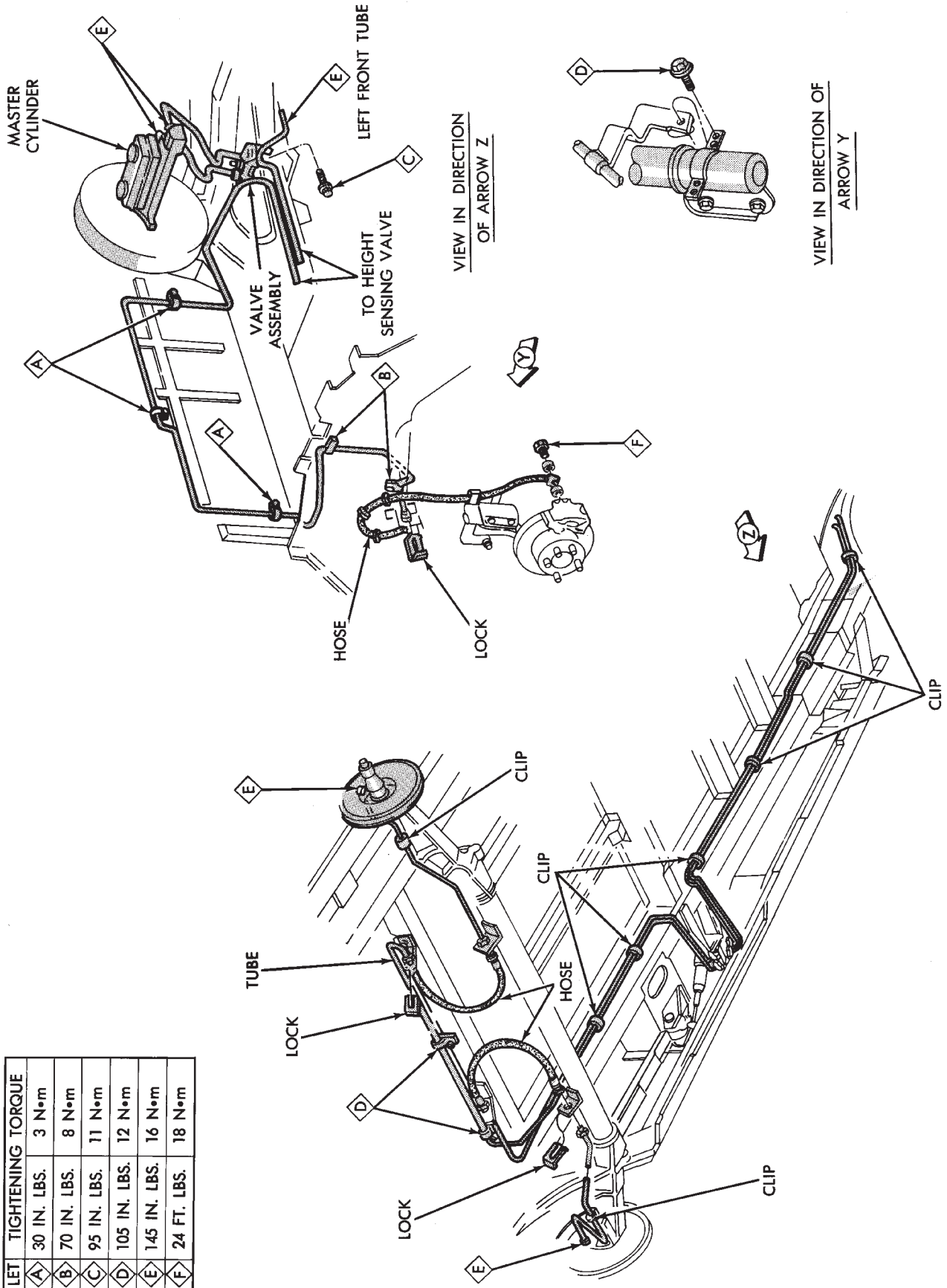

RN194

Fig. 18 Chassis Brake Line Routing Front Wheel Drive With And W/O ABS

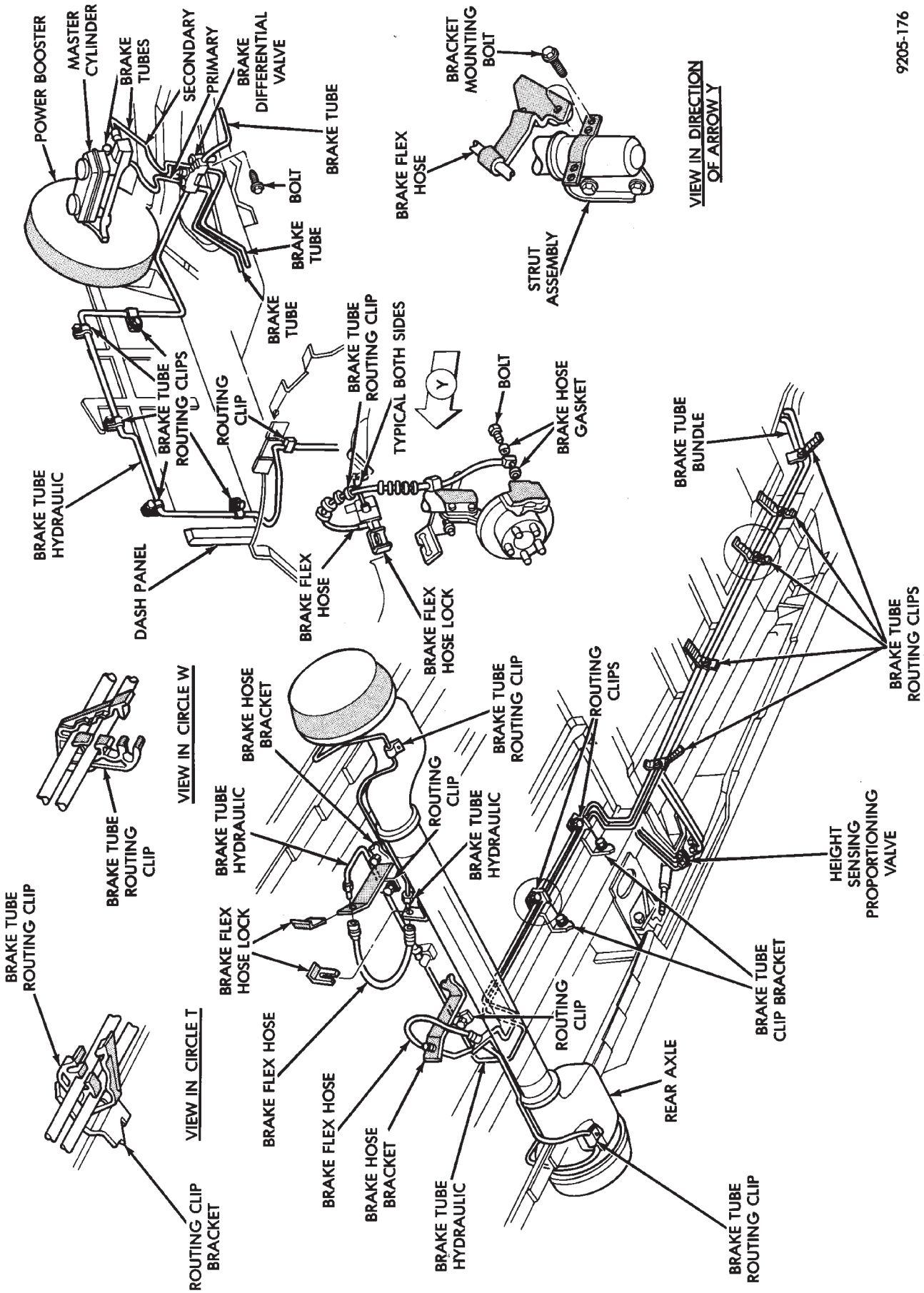

9205-176

Fig. 19 Chassis Brake Line Routing All Wheel Drive With And W/O ABS



9205-177

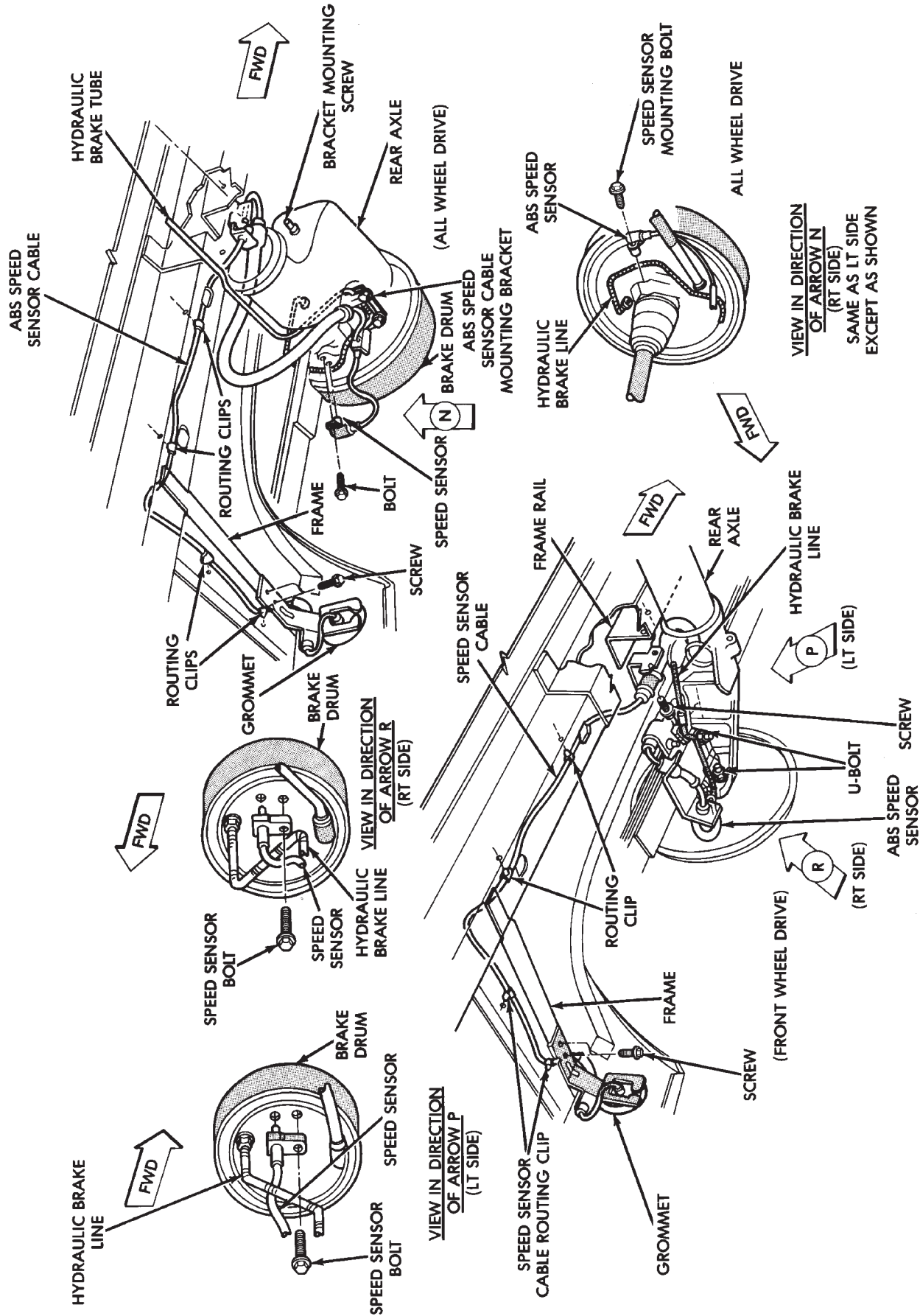
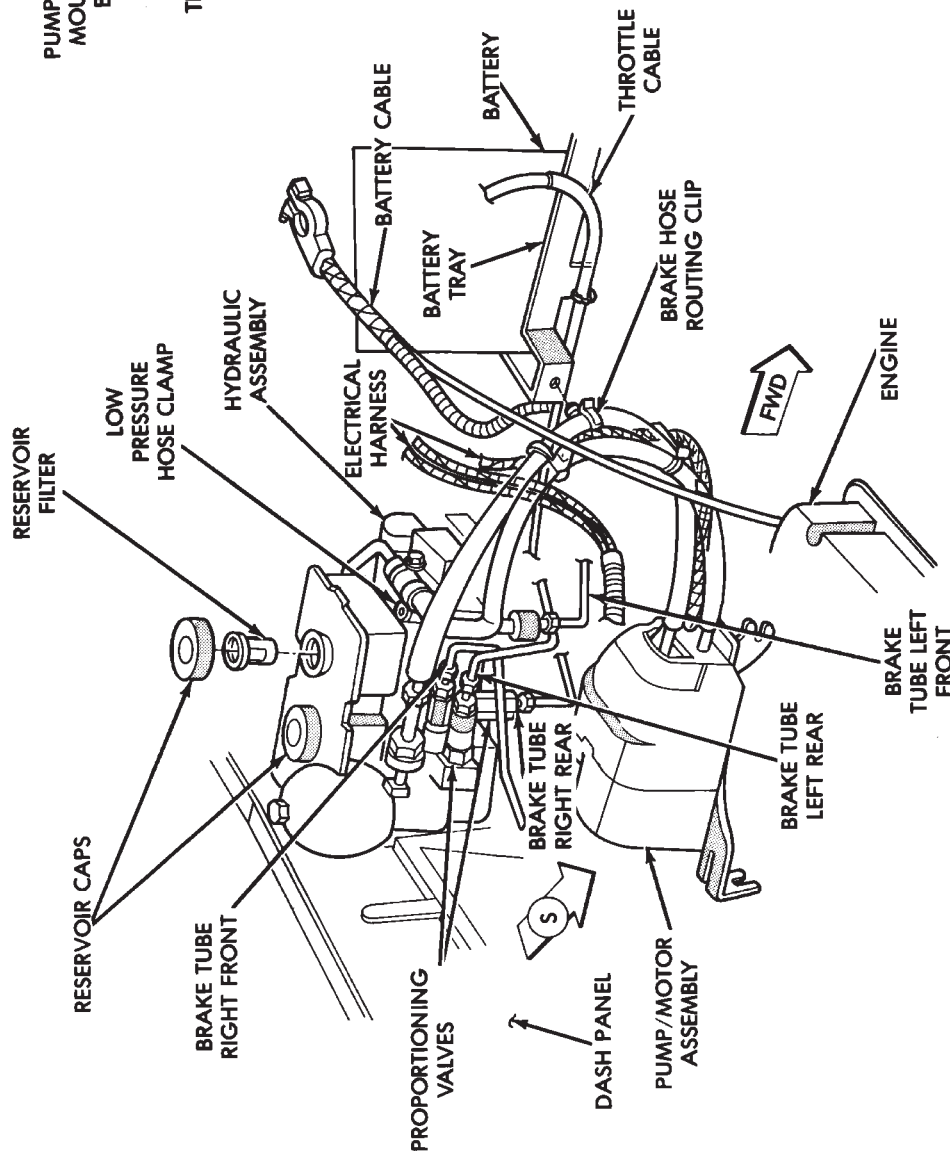
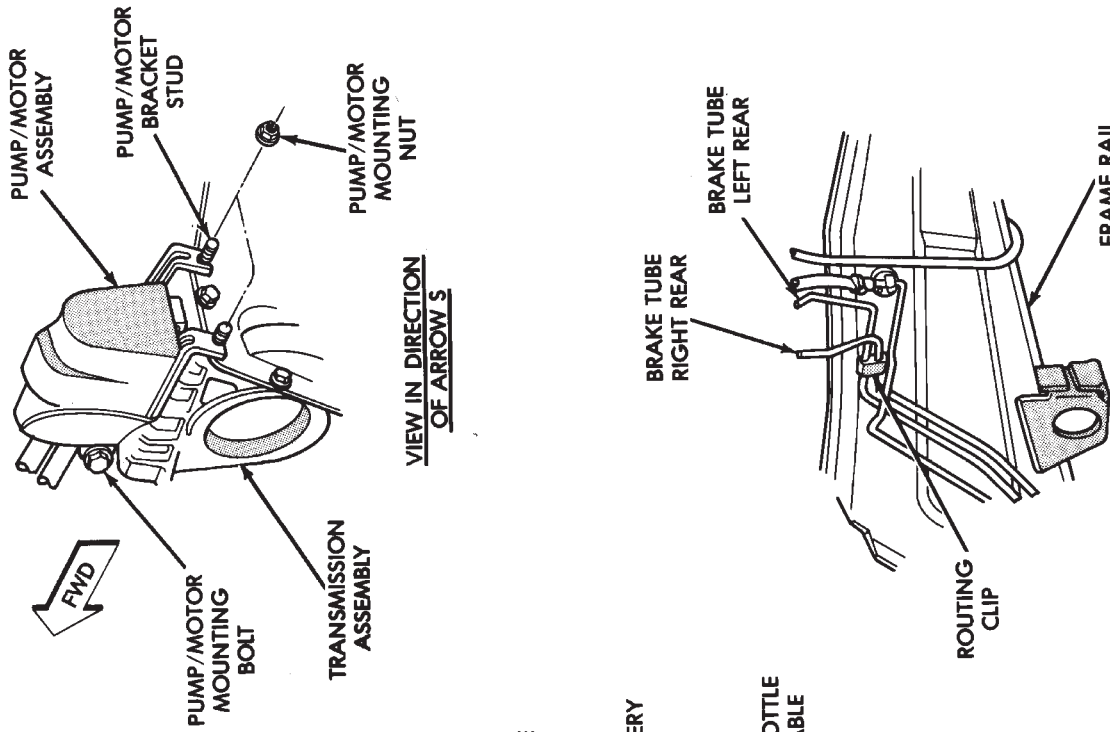

Fig. 20 Rear Axle Brake Line Routing FWD/AWD With ABS



9205-178



VIEW IN DIRECTION OF ARROW V

Fig. 21 Underhood Brake Line Routing FWD/AWD With ABS



BRAKE DIAGNOSIS

BASIC DIAGNOSIS GUIDE

SYMPTOM	CHART 1 MISC. COND.	CHART 2 ACTUATION	CHART 3 POWER BRAKES	CHART 4 BRAKE NOISE	CHART 5 WHEEL BRAKES
BRAKE WARNING LIGHT ON		X	NO		
EXCESSIVE PEDAL TRAVEL	60	X	NO		O
PEDAL GOES TO FLOOR	60	X			
STOP LIGHT ON WITHOUT BRAKES	3X				
ALL BRAKES DRAG	5X	O			
REAR BRAKES DRAG	2X	NO	NO		
GRABBY BRAKES			O		X
SPONGY BRAKE PEDAL		X	NO		
PREMATURE REAR LOCKUP	40	NO	NO		O
EXCESSIVE PEDAL EFFORT	1X		O		
ROUGH ENGINE IDLE			O		
BRAKE CHATTER (ROUGH)		NO	NO		X
SURGE DURING BRAKING					X
NOISE DURING BRAKING				X	
RATTLE OR CLUNKING NOISE		NO		X	
PEDAL PULSATES DURING BRAKING		NO	NO		X
PULL TO RIGHT OR LEFT		NO	NO		X

NO: NOT POSSIBLE CAUSE

X: MOST LIKELY CAUSE

O: POSSIBLE CAUSE



BRAKE SYSTEM DIAGNOSTICS

CHART 1 MISCELLANEOUS CONDITIONS

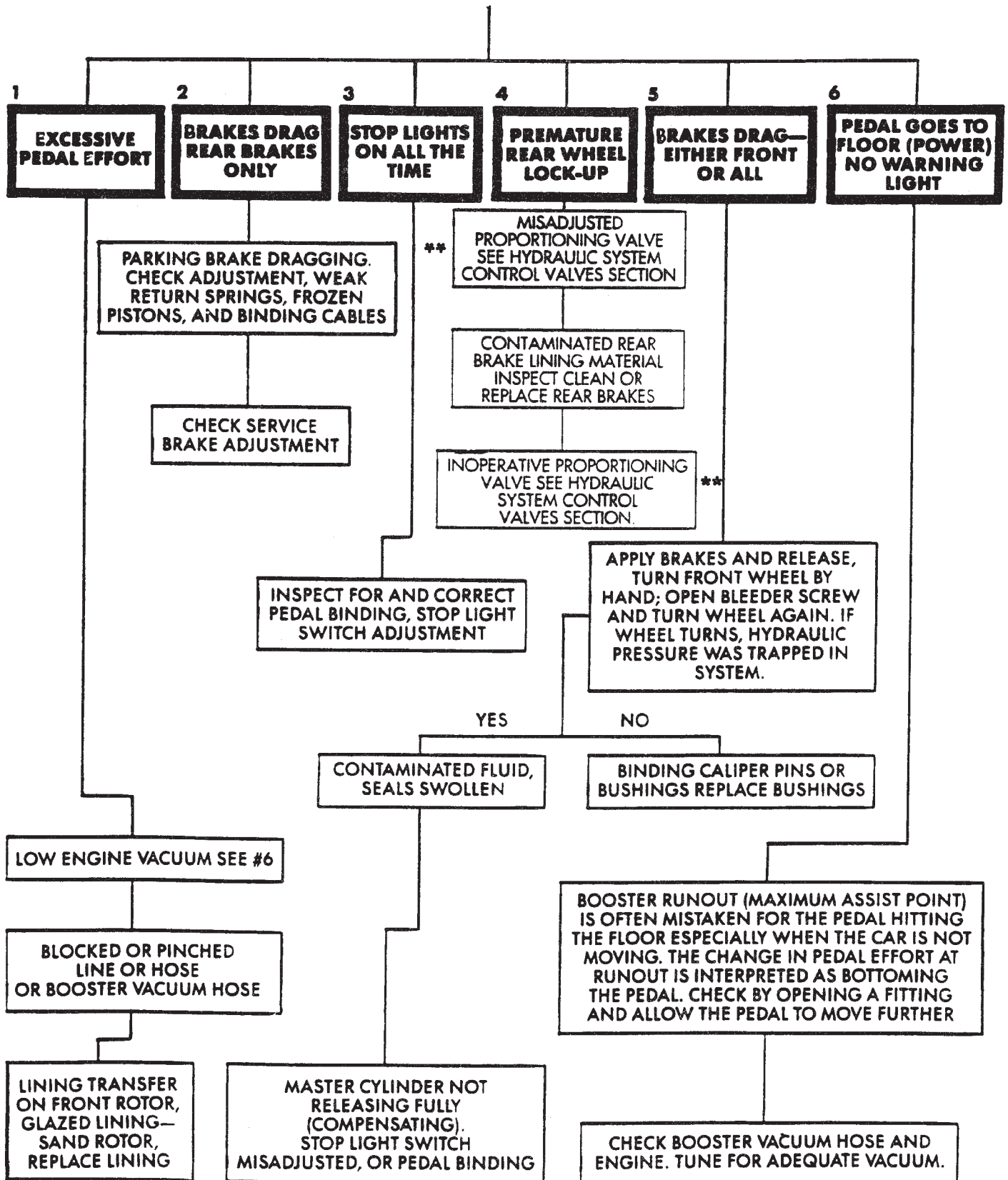

BRAKE SYSTEM DIAGNOSTICS

CHART 2 ACTUATION

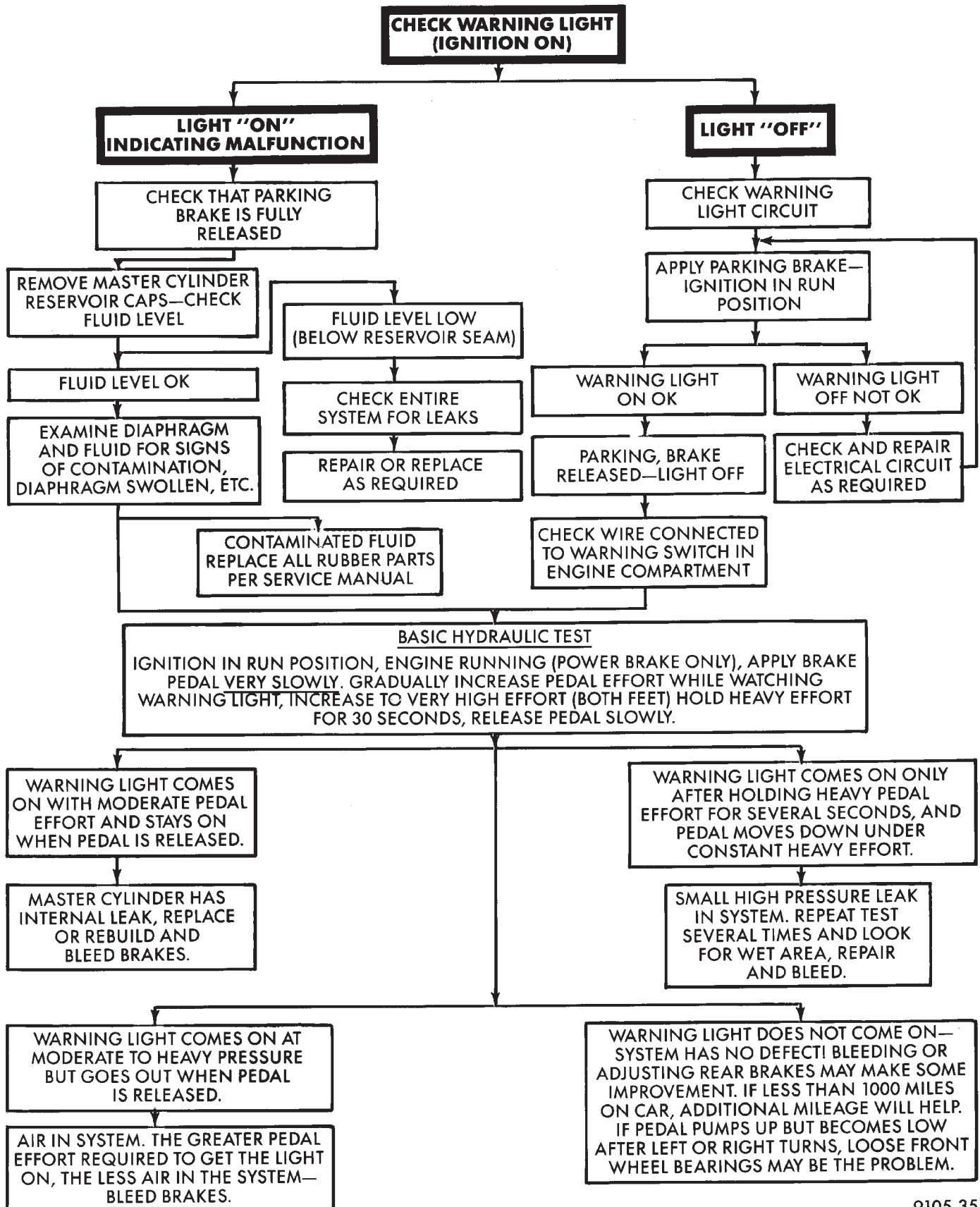

BRAKE SYSTEM DIAGNOSTICS

CHART 3 POWER BRAKES

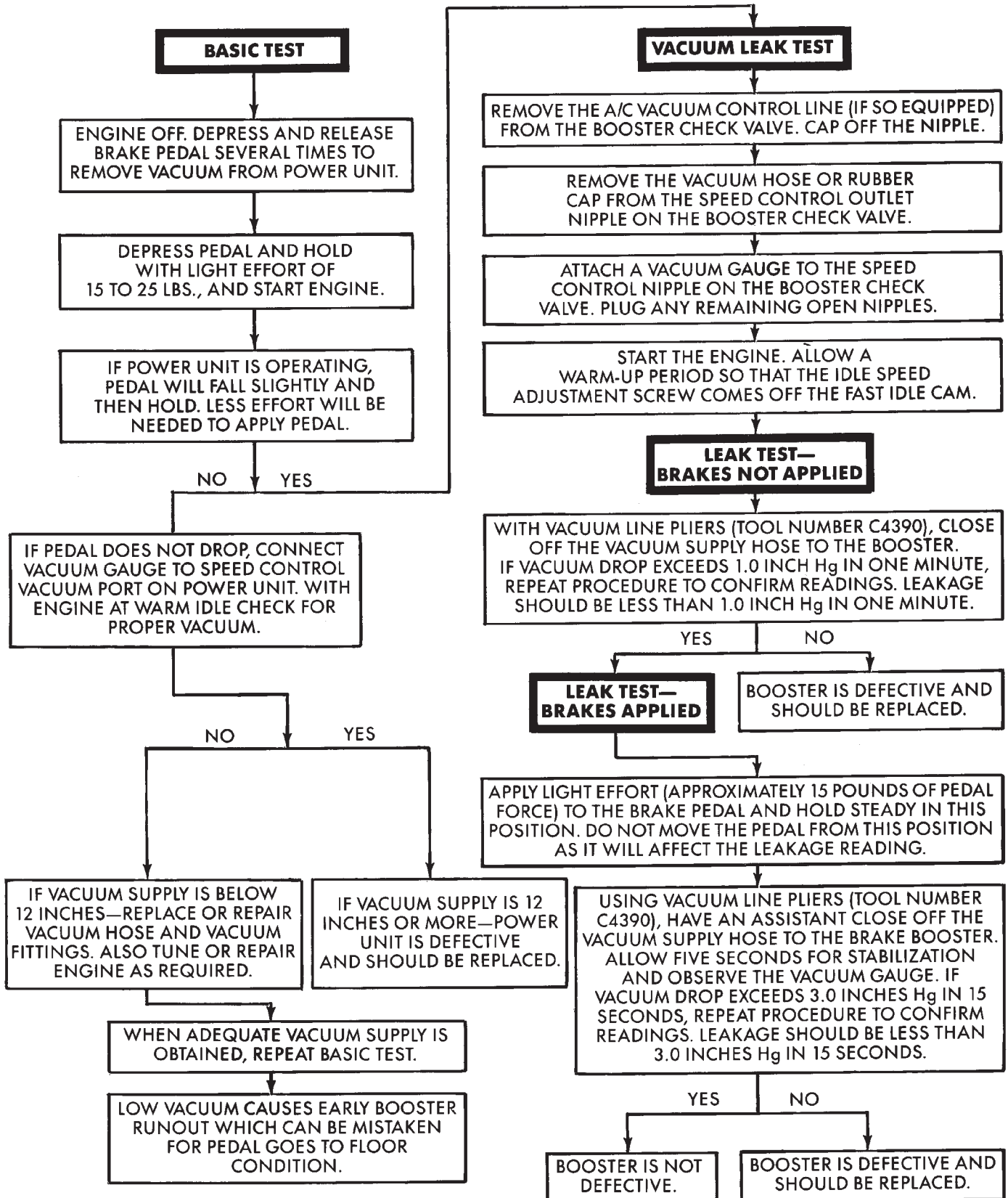



BRAKE SYSTEM DIAGNOSTICS

CHART 4 BRAKE NOISE

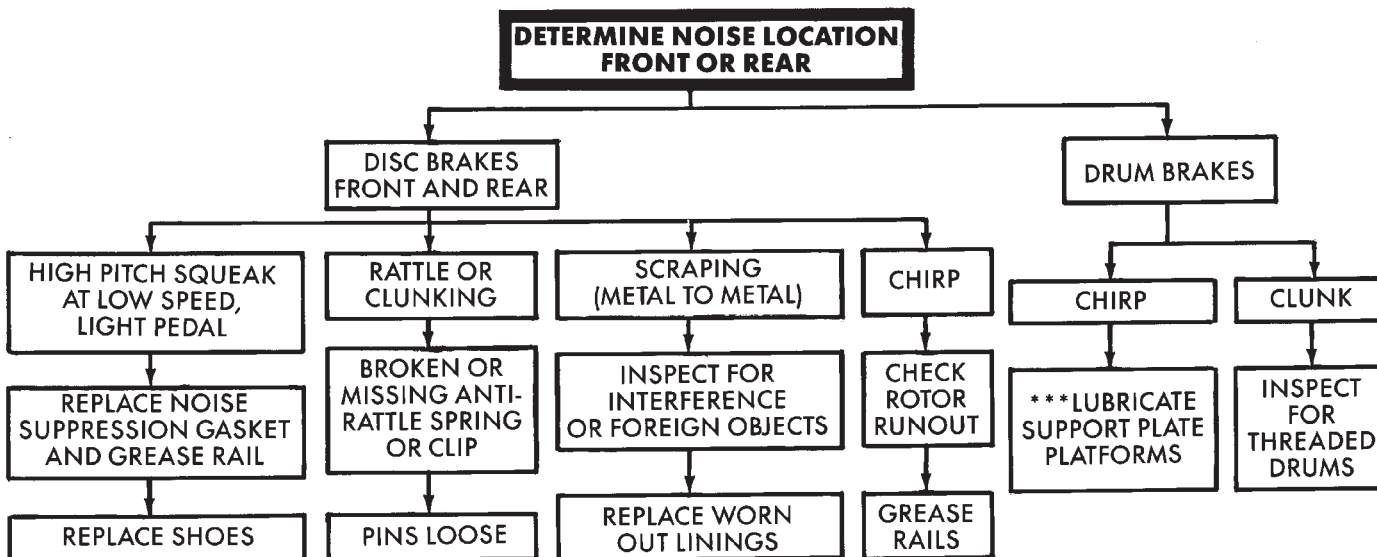

***MOPAR MULTIPURPOSE LUBRICANT, OR EQUIVALENT.

9105-37

BRAKE SYSTEM DIAGNOSTICS

CHART 5 WHEEL BRAKES

ROAD TEST CAR

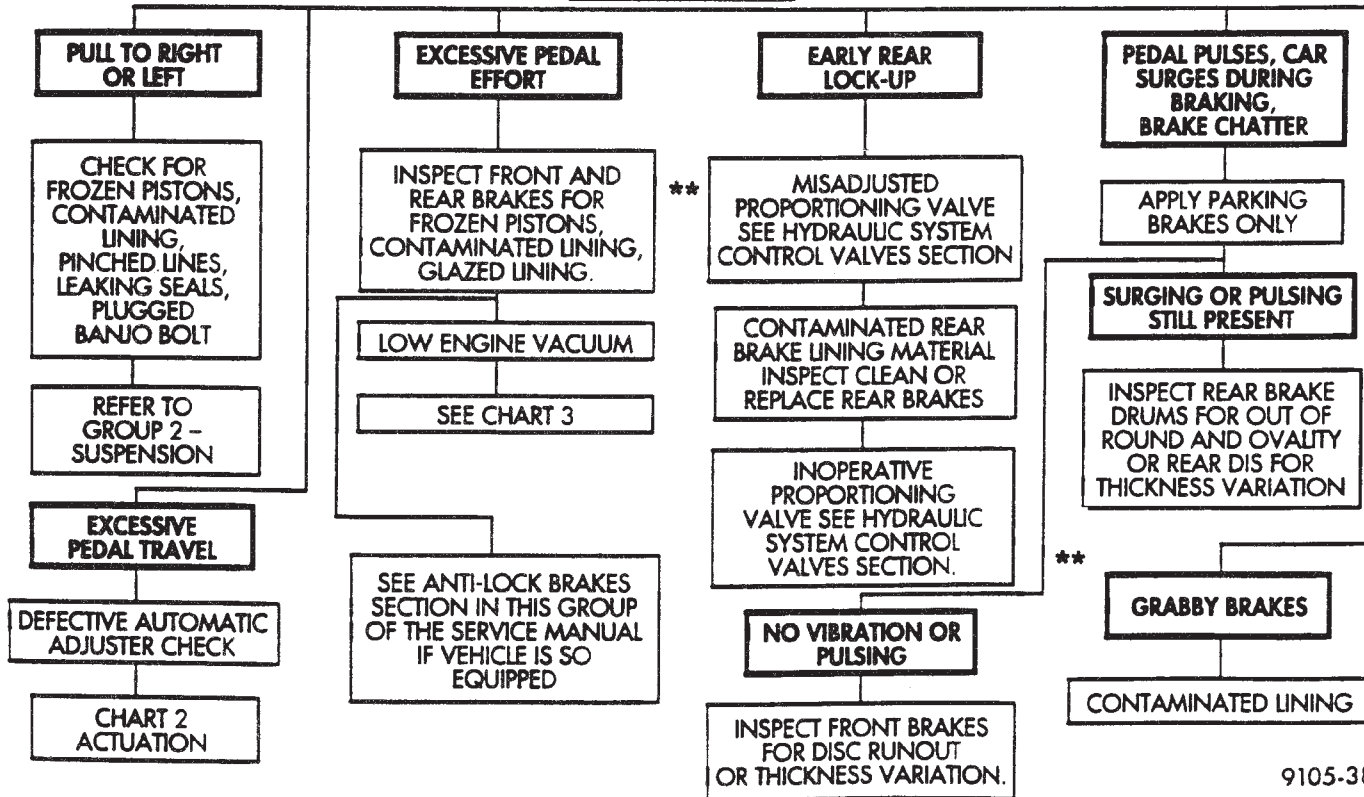

9105-38

DRUM BRAKES

INDEX

	page		page
Brake Drum Installation	24	Remove and Install Brake Support Plate	24
Drum Refacing Recommendations	23	Service Procedures	20
General Information	20		

GENERAL INFORMATION

Rear wheel brakes (Fig. 1 & 2) are two shoe, internal expanding type with automatic application adjusters. The lower ends of the brake shoes are connected by a tubular star wheel adjusting screw (Figs.1 and 2).

WARNING: DUST AND DIRT ON BRAKE PARTS GENERATED DURING THE NORMAL USE AND WEAR OF MOTOR VEHICLE BRAKE SYSTEMS CAN CONTAIN ASBESTOS FIBERS. BREATHING EXCESSIVE CONCENTRATIONS OF ASBESTOS FIBERS CAN CAUSE SERIOUS BODILY HARM, SUCH AS ASBESTOSIS AND CANCER. EXTREME CARE SHOULD BE EXERCISED WHILE SERVICING BRAKE ASSEMBLIES OR COMPONENTS.

DO NOT CLEAN BRAKE ASSEMBLIES OR COMPONENTS WITH COMPRESSED AIR OR BY DRY BRUSHING; USE A VACUUM CLEANER SPECIFICALLY RECOMMENDED FOR USE WITH ASBESTOS FIBERS. IF A SUITABLE VACUUM CLEANER IS NOT AVAILABLE, CLEANING SHOULD BE DONE WET USING A WATER DAMPENED CLOTH.

DO NOT CREATE DUST BY SANDING, GRINDING, AND/OR SHAVING BRAKE LININGS OR PADS UNLESS SUCH OPERATION IS DONE WHILE USING PROPERLY EXHAUST VENTILATED EQUIPMENT.

DISPOSE OF ALL DUST AND DIRT SUSPECTED TO CONTAIN ANY ASBESTOS FIBERS IN SEALED BAGS OR CONTAINERS TO MINIMIZE DUST EXPOSURE TO YOURSELF AND OTHERS.

FOLLOW ALL RECOMMENDED PRACTICES PRESCRIBED BY THE OCCUPATIONAL SAFETY AND HEALTH ADMINISTRATION AND THE ENVIRONMENTAL PROTECTION AGENCY. FOR THE HANDLING, PROCESSING, AND DISPOSITION OF DUST OR DIRT WHICH MAY CONTAIN ASBESTOS FIBERS.

SERVICE PROCEDURES*BRAKE DRUM REMOVAL***FRONT WHEEL DRIVE**

(1) Remove the tire and wheel assembly from the vehicle

(2) Remove the rear adjusting hole cover plug, from the rear brake adjusting access hole in brake support plate.

(3) Insert a thin screwdriver into brake adjusting hole and hold adjusting lever away from notches of adjusting screw star wheel.

(4) Insert Tool C-3784 into brake adjusting hole and engage notches of brake adjusting screw star wheel. Release brake by prying down with adjusting tool.

(5) Remove the rear hub and drum assembly from vehicle.

(6) Inspect brake lining for wear, shoe alignment, or contamination from grease or brake fluid.

ALL WHEEL DRIVE

(1) Remove rear wheel and tire assembly from vehicle. Access for the adjuster screw assembly on ALL WHEEL DRIVE APPLICATIONS is through the access hole on the front of the brake drum.

(2) Insert a thin screwdriver into brake shoe adjusting hole. Hold adjusting lever away from notches of adjusting screw star wheel.

(3) Insert Tool C-3784 into brake adjusting hole and engage notches of brake adjusting screw star wheel. Release brake by prying up with the adjusting tool.

(4) Remove rear brake drum from the hub assembly. Rear hub and bearing DOES not come off with the brake drum on all wheel drive applications.

(5) Inspect brake lining for wear, shoe alignment, or contamination from grease or brake fluid.

- For illustrations of the above procedures, pertaining to adjuster screw assembly adjustments see the Service Adjustments section of this group.

*BRAKE SHOE REMOVAL***BRAKE SHOE ASSEMBLIES**

The procedure for rear brake shoe removal, is the same for both the Front Wheel Drive and All Wheel Drive van applications. Though some of the brake components may be slightly different (Figs. 1 & 2).

Support plate and park brake assemblies ARE NOT SYMMETRICALLY OPPOSITE.

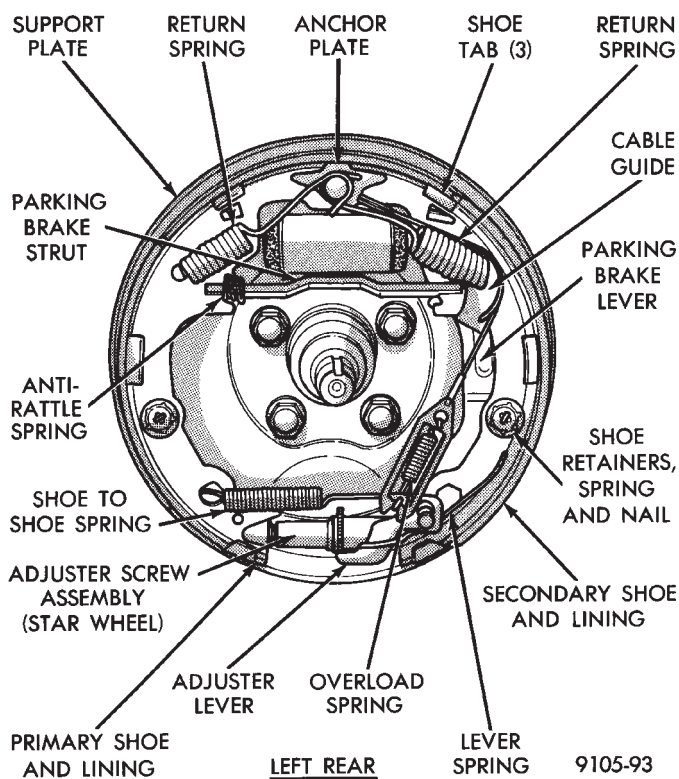

Fig. 1 Rear Wheel Brake F.W.D. Applications

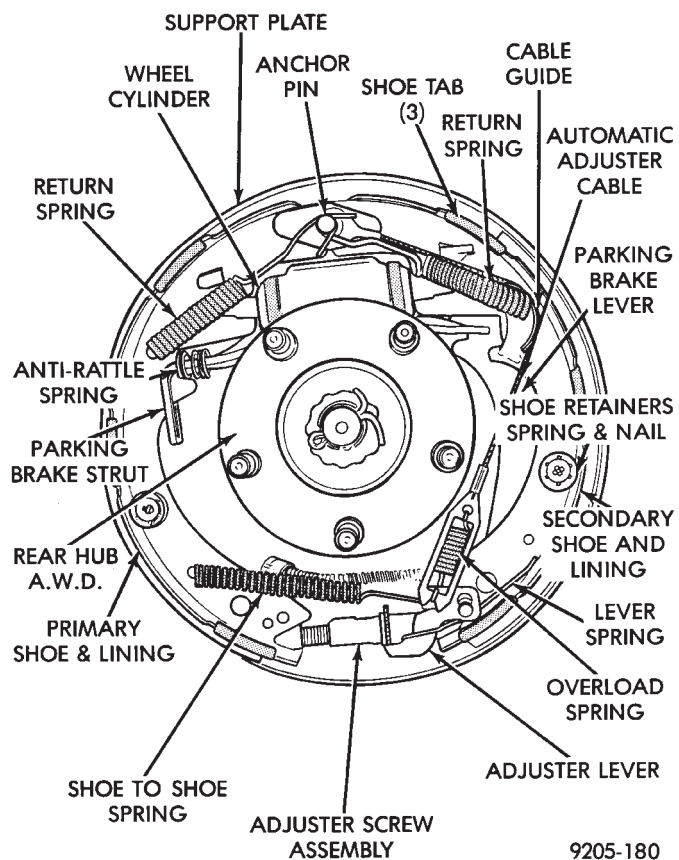

Fig. 2 Rear Wheel Brake A.W.D. Applications

Right Side: Park brake cable enters support plate at rear. Cable attaches to the internal park brake lever which is attached to the primary shoe.

Left Side: Park brake cable enters support plate at front (traditional) and attaches to the internal park brake lever which is attached to the secondary shoe.

(1) Remove rear wheel and tire assembly from vehicle.

(2) Remove hub and drum assembly on front wheel drive applications. On all wheel drive applications remove only the brake drum, the hub assembly (Fig. 2) will remain on the vehicle.

(3) Using Remover Special Tool C-3785, remove brake shoe return springs (Fig. 3). (Note how secondary shoe return spring overlaps primary shoe return spring). (Figs. 1 and 2).

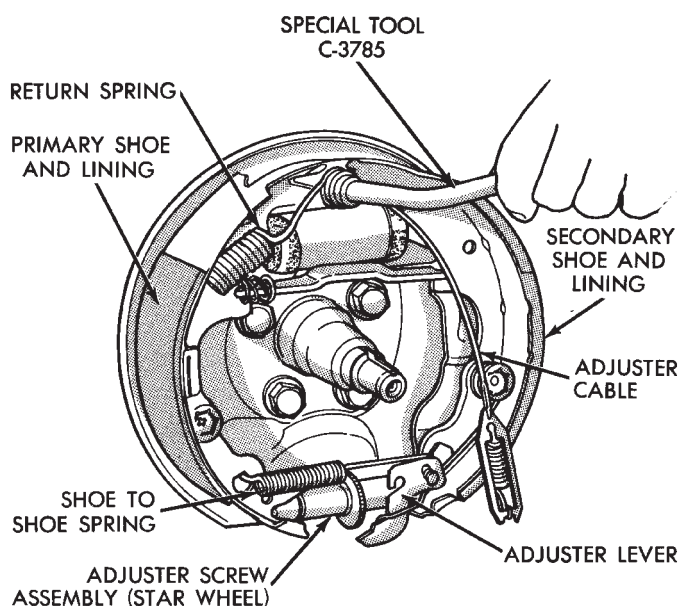

Fig. 3 Removing or Installing Brake Shoe Return Springs

(4) Slide eye of automatic adjuster cable off anchor pin and then unhook from adjusting lever (Fig. 2) Remove cable, overload spring, cable guide and anchor pin plate.

(5) Disengage adjusting lever (Figs. 1 & 2) from spring by sliding it forward to clear pivot, then working it out from under spring. Remove spring from pivot. Remove shoe to shoe spring from secondary shoe web and disengage from primary shoe web. Remove spring.

(6) Disengage primary and secondary shoes from the adjuster screw assembly. Remove adjuster screw assembly.

(7) Remove brake shoe retainers, springs and nails using Remover Special Tool C-4070, (Fig. 4), and remove from support.

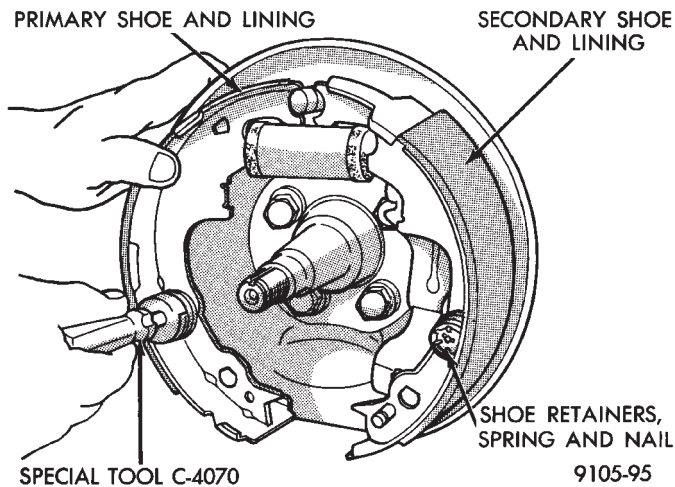

Fig. 4 Removing or Installing Shoe Retainers, Springs, and Nails

(8) Remove parking brake lever (Fig. 1 & 2) from secondary shoe, left side or primary shoe, right side. Remove shoes.

(9) Disengage parking brake lever from parking brake cable.

CLEANING AND INSPECTION

Wipe with a water dampened cloth the metal portions of the brake shoes. Examine the lining contact pattern to determine if the shoes are bent. The lining should show contact across the entire width, extending from heel to toe. Shoes showing contact only on one side should be replaced. Shoes having sufficient lining but lack of contact at toe and heel may be improperly ground.

Clean the brake support plate, using a suitable solvent. Then inspect for rough or rusted shoe contact areas. Clean and inspect the adjusting screws for damaged threads. Apply a thin film of lubricant such as Mopar® Multi-Purpose Lubricant or equivalent to the adjuster threads, socket and washer (Fig. 8). Replace adjuster screw assembly if corrosion of any part inhibits very free operation.

Install new brake shoe return springs and holddown springs where the old springs have been subjected to overheating or if their strength is questionable. Spring paint discoloration or distorted end coils indicate a spring that had been overheated.

BRAKE SHOE INSTALLATION

Lubricate the six shoe tab contact pads on support plate with a thin film of Mopar® Multi-Purpose Lubricant, or equivalent (Fig. 5).

(1) Slide primary shoe against support plate, at the same time engage shoe web with wheel cylinder piston and against anchor. Using Installer Special Tool C-4070, install shoe retaining nail, retainer, and spring (Fig. 4).

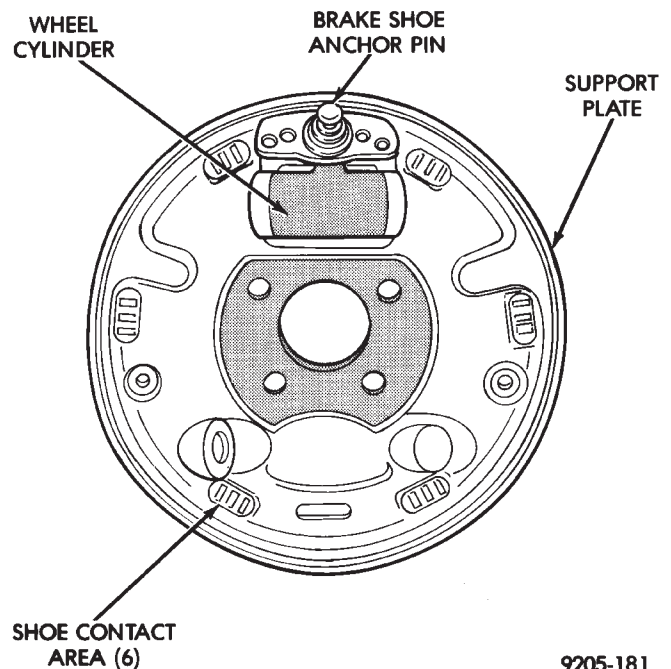

Fig. 5 Shoe Contact Pads on Support

(2) Install anchor plate over anchor, then install eye of adjuster cable over anchor (Fig. 2).

(3) Engage primary shoe return spring in web of shoe and install free end over anchor, using Spring Installer, Special Tool C-3785 (Fig. 3).

(4) Slide parking brake strut into slot in parking brake lever. Slide anti-rattle spring over free end of strut (Fig. 6).

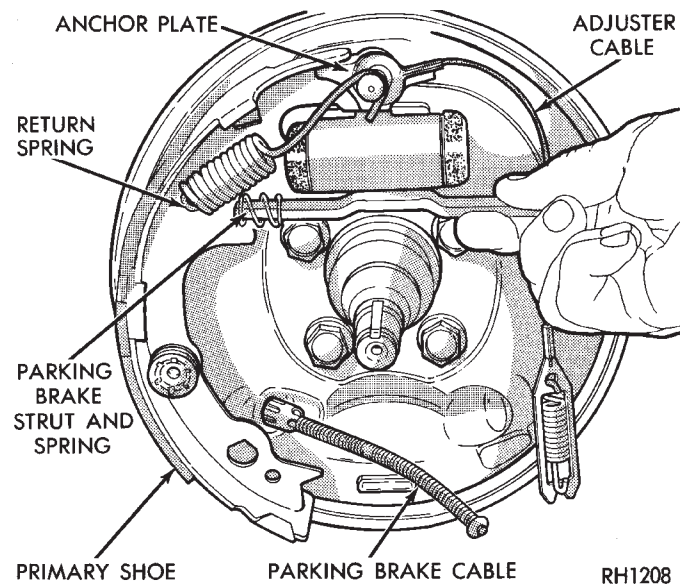

Fig. 6 Removing or Installing Parking Brake Strut and Spring

(5) Engage parking brake lever with cable. Install parking brake lever into rectangular hole of secondary brake shoe (left side) or primary shoe (right side) (Fig. 7).

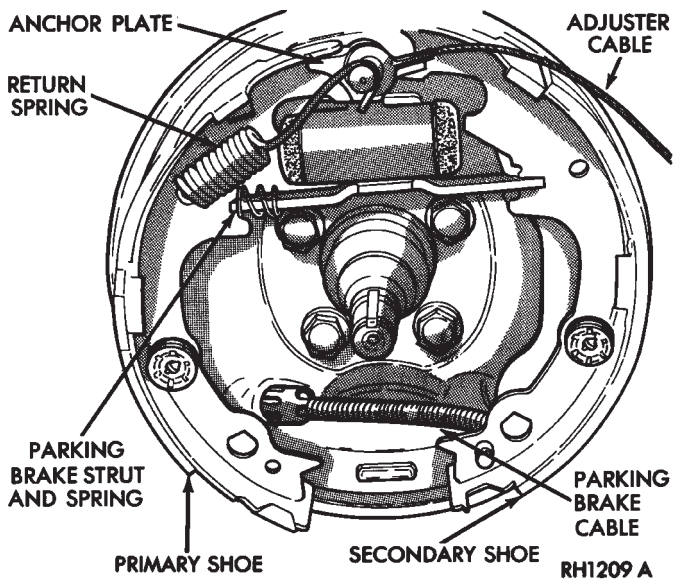

Fig. 7 Installing Parking Brake Cable

(6) Slide secondary shoe into position and engage with wheel cylinder piston and free end of strut. Install shoe retaining nail, retainer, and spring using Installer, Special Tool C-4070 (Fig. 4).

(7) Insert protruding hole rim of cable guide (Fig. 1 or 2) into hole in secondary shoe web. Holding guide in position, engage secondary shoe return spring through both, hole in guide, and hole in web. Using Installer, Special Tool C-3785, install spring over anchor (Fig. 3). (Be sure cable guide remains flat against shoe web and that secondary spring overlaps primary (Fig. 1 & 2). Using pliers, squeeze ends of spring loops (around anchor) until parallel.

(8) Install adjuster screw assembly (Fig. 8) between primary and secondary shoes, with star wheel of adjuster screw assembly next to secondary shoe (Fig. 1 & 2). The left star wheel adjusting stud end is stamped (L) (indicating its position on the vehicle) and the star wheel is cadmium plated (Fig. 8). The right star wheel is black and the adjusting stud end is stamped (R). Install shoe to shoe spring between shoes (Fig. 1). (Engage primary shoe first).

(9) Install adjusting lever spring (Fig. 1 & 2) over pivot pin on shoe web. Install adjusting lever under spring and over pivot pin. Slide lever slightly rearward to lock in position.

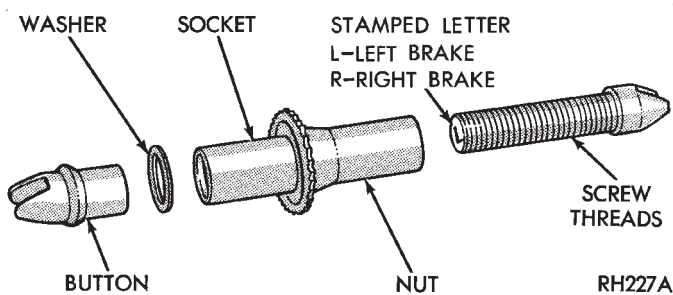

Fig. 8 Adjuster Screw Assembly

(10) Thread adjuster cable over guide and hook end of overload spring in lever (Fig. 1 & 2). (Be sure eye of cable is pulled tight against anchor and in a straight line with guide). Check operation of automatic application adjuster by pulling adjuster cable rearward, star wheel should rotate upwards.

DRUM REFACING RECOMMENDATIONS

All drums will show markings of maximum allowable diameter (Fig. 1). For example, a drum will have a marking of MAX. DIA. 231.0 mm (9.09 inch). This marking includes 0.76 mm (0.030 inch) for allowable drum wear beyond the recommended 1.52 mm (0.060 inch) of drum refacing.

Drum Refacing Measure the drum runout and

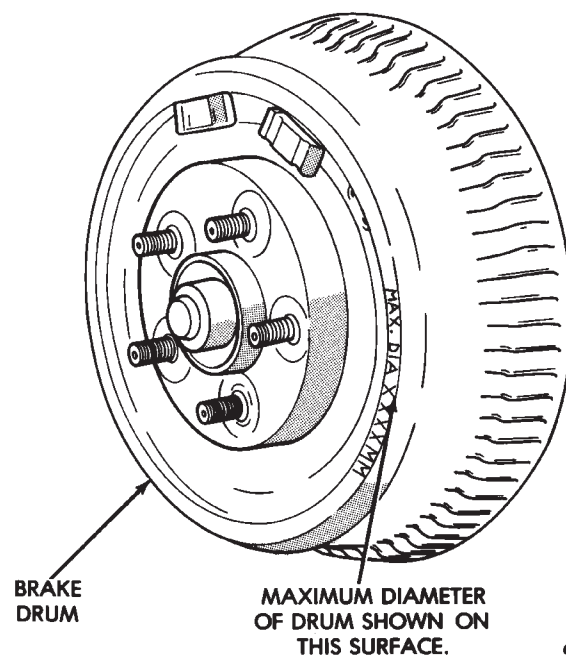

Fig. 1 Drum Maximum Diameter Identification

diameter with an accurate gauge. There should be no variation in the drum diameter greater than 0.090 mm (0.004 inch). Drum runout should not exceed 0.15 mm (0.006 inch) out of round. If the drum runout or diameter variation exceed these values the drum should be refaced. For best results in eliminating the irregularities that cause brake roughness and surge, the amount of material removed during a single cut should be limited to 0.13 mm (0.005 inch). When the entire braking surface has been cleaned. A final cut of 0.0254 mm (0.001 inch) will ensure a good drum surface providing the equipment used is capable of the precision required for resurfacing brake drums. Deeper cuts are permissible for the sole purpose of removing deep score marks. **Do not reface more than 1.52 mm (0.60 inch) over the standard drum diameter.**

BRAKE DRUM INSTALLATION

FRONT WHEEL DRIVE

- (1) Install brake drum/hub assembly on spindle, be sure inner bearing and grease seal is installed in hub.
- (2) Install outer bearing, thrust washer, and nut.
- (3) Tighten wheel bearing adjusting nut to 27 to 34 N•m (240 to 300 in. lbs.) while rotating hub. This seats the bearings.
- (4) Back off adjusting nut 1/4 turn (90°) then tighten adjusting nut finger tight.
- (5) Position lock nut with one pair of slots in line with cotter pin hole. Install cotter pin.
- (6) Install grease cap and wheel and tire assemblies. Tighten wheel stud nuts to 129 N•m (95 ft. lbs.) on all models. Install wheel covers (if equipped).
- (7) Adjust brakes as described under Service Adjustments at front of this section.

ALL WHEEL DRIVE

- (1) Install brake drum on hub.
- (2) Install wheel and tire assemblies. Tighten wheel stud nuts to 129 N•m (95 ft. lbs.) on all models. Install wheel covers (if equipped).
- (3) Adjust brakes as described under Service Adjustments at front of this section.

BRAKE SUPPORT PLATE

FRONT WHEEL DRIVE

REMOVE

- (1) With wheel and brake drum removed. Remove brake shoe assemblies and disconnect brake cable, from parking brake lever.
- (2) Using a suitable tool such as an aircraft type hose clamp or a 14mm box wrench. Compress the flared legs of cable retainer and pull brake cable out of brake support plate (Fig. 1).
- (3) Disconnect hydraulic brake tube from wheel cylinder (Fig. 2).
- (4) Remove wheel cylinder to brake support plate attaching bolts and washers (Fig. 2).
- (5) Remove support plate and spindle mounting bolts (Fig. 3).
- (6) Remove support plate, spindle and gasket from rear axle.

ALL WHEEL DRIVE

REMOVE

- (1) With wheel and brake drum removed, remove brake shoe assemblies and disconnect parking brake cable from parking brake lever.
- (2) Remove the rear axle half shaft from the vehicle. Refer to Group 3 Rear Axle in this service manual for specific removal procedure.

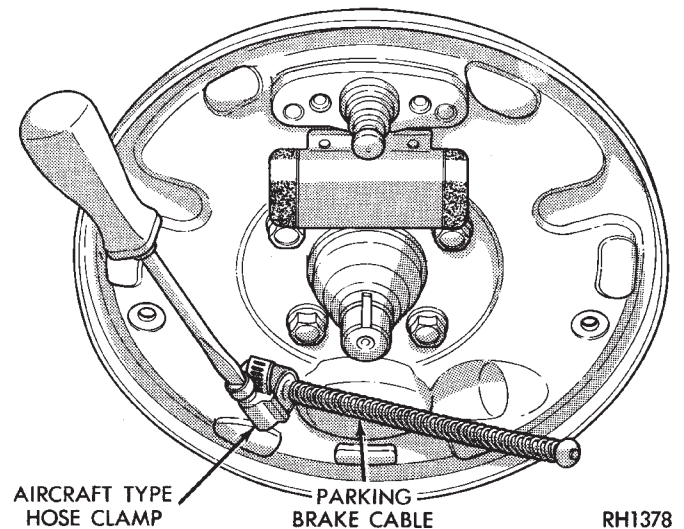

Fig. 1 Removing Brake Cable from Support Plate

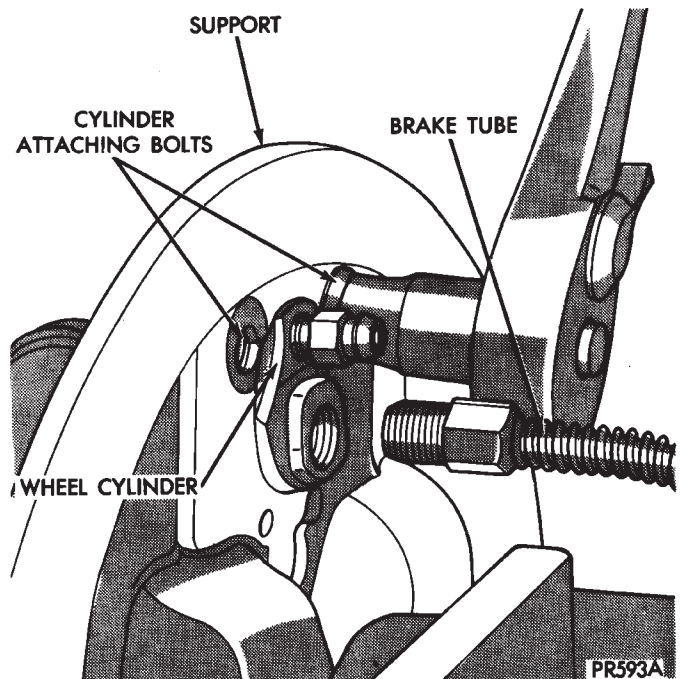
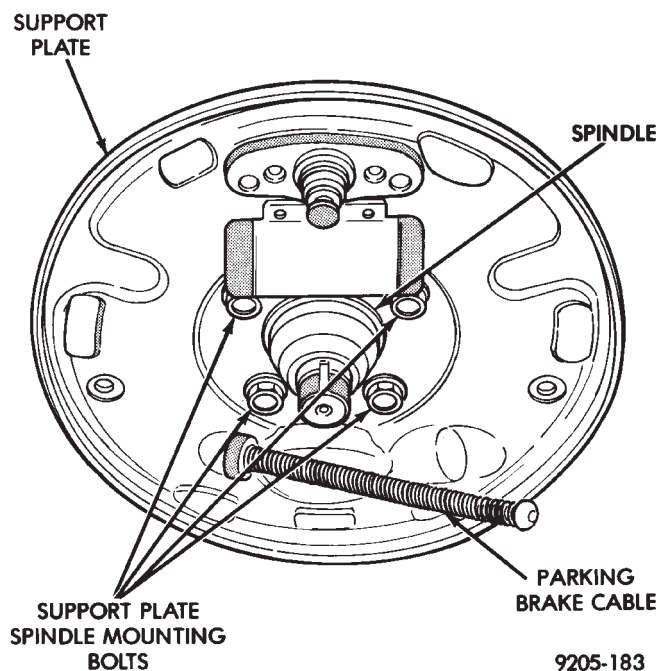

Fig. 2 Removal And Installation Brake Tube And Wheel Cylinder

- (3) Using a suitable tool such as an aircraft type hose clamp or a 14 mm box wrench compress the flared legs on park brake cable retainer. Then pull the parking brake cable out of brake support plate (Fig. 1).
- (4) Disconnect hydraulic brake tube from wheel cylinder (Fig. 2).
- (5) Remove support plate to wheel cylinder attaching bolts and washers (Fig. 2).
- (6) Remove support plate and rear bearing hub unit mounting bolts (Fig. 4).
- (7) Remove rear bearing hub unit, support plate and gasket from the rear axle.



9205-183

Fig. 3 Brake Support And Spindle Mounting Bolts

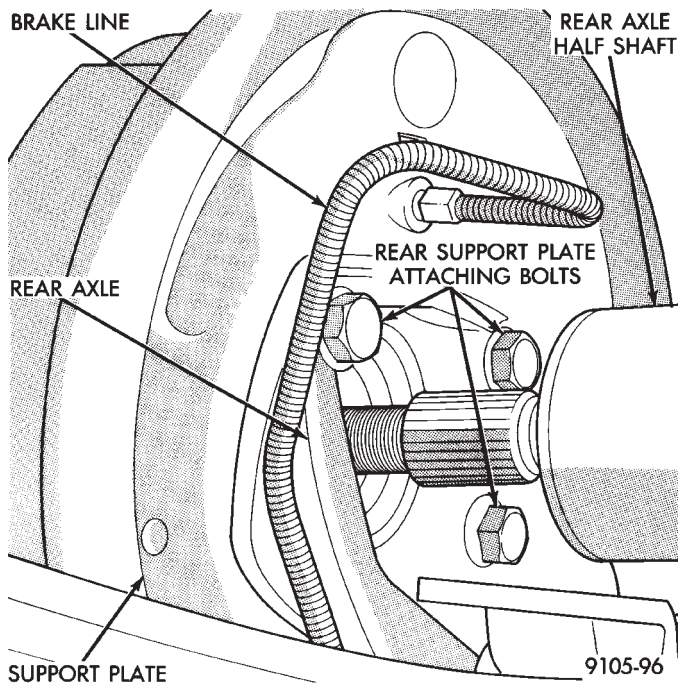

9105-96

Fig. 4 Remove and Install Brake Support Plate and Bearing Hub Bolts.

FRONT WHEEL DRIVE

INSTALL

(1) Install gasket, support plate and spindle and onto the rear axle.

(2) Apply sealant such as Mopar® Gasket-In-A-Tube or equivalent around wheel cylinder mounting surface (Fig. 5).

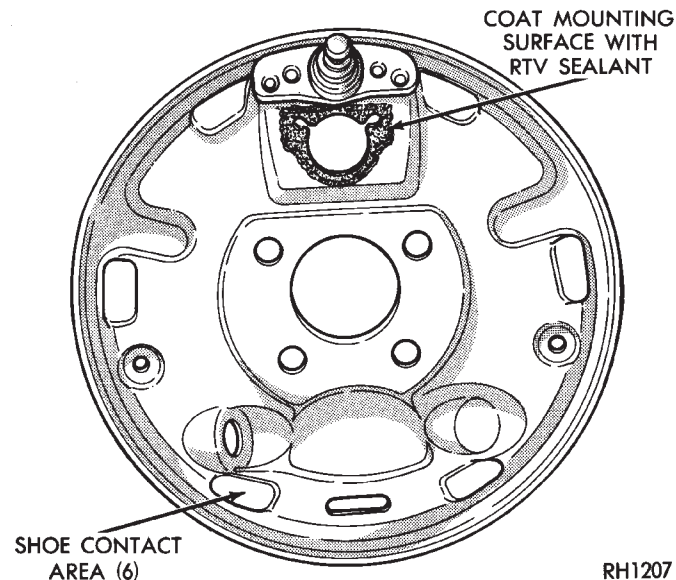

RH1207

Fig. 5 Apply Sealant on Support Plate

(3) Install wheel cylinder onto brake support, and tighten the wheel cylinder to brake support plate attaching bolts (Fig. 2) to 8 N•m (75 in. lbs.). Attach hydraulic brake tube to wheel cylinder, and tighten tube to wheel cylinder fitting to 17 N•m (145 in. lbs.)

(4) Insert parking brake cable into support plate and attach cable to parking brake lever.

(5) Install brake shoes onto support plate.

(6) Install rear brake drum onto rear hub. Install rear wheel and tire assembly, tighten wheel stud nuts to 129 N•m (95 ft. lbs.).

(7) Adjust the rear brakes, (See Adjusting Service Brakes) in Service Adjustments section in this group of the service manual.

(8) Bleed the entire brake system. See (Bleeding Brake System) in Service Adjustments section in this group of the service manual.

ALL WHEEL DRIVE

INSTALL

(1) Install gasket, support plate and rear bearing hub unit onto the rear axle (Fig. 4). Tighten the rear bearing hub unit/support plate to axle attaching bolts to 108 N•m (80 ft. lbs.).

(2) Apply sealant such as Mopar® Gasket-In-A-Tube or equivalent around wheel cylinder mounting surface (Fig. 5).

(3) Install wheel cylinder onto brake support, and tighten the wheel cylinder to brake support plate attaching bolts (Fig. 2) to 8 N•m (75 in. lbs.). Attach hydraulic brake tube to wheel cylinder, and tighten tube to wheel cylinder fitting to 17 N•m (145 in. lbs.).

(4) Install the rear axle half shaft. Refer to Group 3 Rear Axle in this service manual for procedure and torque specifications.



- (5) Insert parking brake cable into support plate and attach cable to parking brake lever.
- (6) Install brake shoes on support plate.
- (7) Install rear brake drum onto rear hub. Install rear wheel and tire assembly, tighten wheel stud nuts to 129 N•m (95 ft. lbs.).

- (8) Adjust the rear brakes, (See Adjusting Service Brakes) in Service Adjustments section in this group of the service manual.
- (9) Bleed the entire brake system. See (Bleeding Brake System) in Service Adjustments section in this group of the service manual.

WHEEL CYLINDERS

INDEX

	page		page
General Information	26	Service Procedures	26
Installing Wheel Cylinders	27		

GENERAL INFORMATION

The piston boots are of the push-on type and prevent moisture from entering the wheel cylinder.

To perform service operations or inspections of the rear wheel brake cylinders. It will be necessary to remove the cylinders from the support plate and disassemble on the bench.

CAUTION: Wheel cylinders with cup expanders must have cup expanders after any service procedures (reconditioning or replacement).

SERVICE PROCEDURES

REMOVING WHEEL CYLINDERS FROM BRAKE SUPPORT PLATES

With brake drums removed, inspect the wheel cylinder boots for evidence of a brake fluid leak. Then block the brake pedal in the stroke position, and visually check the boots for cuts, tears, or heat cracks. If any of

these conditions exist, the wheel cylinders should be completely cleaned, inspected and new parts installed. (A slight amount of fluid on the boot may not be a leak, but maybe preservative fluid used at assembly.)

- (1) In case of a leak, remove brake shoes, (replace if soaked with grease or brake fluid.)
- (2) Disconnect brake tube from wheel cylinder (Fig. 1).
- (3) Remove the rear wheel cylinder attaching bolts (Fig. 1). Then pull wheel cylinder assembly off the brake support plate (Fig. 2).

DISASSEMBLING WHEEL CYLINDERS

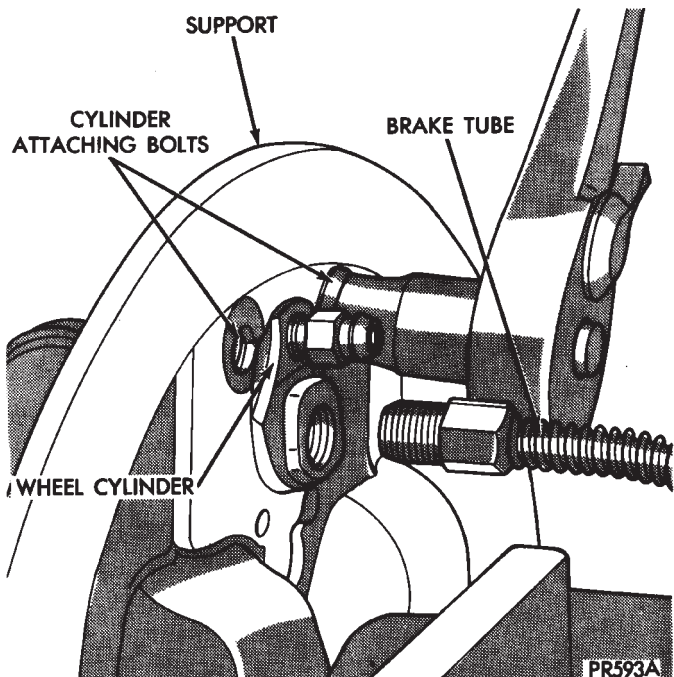

Fig. 1 Brake Tube Disconnected

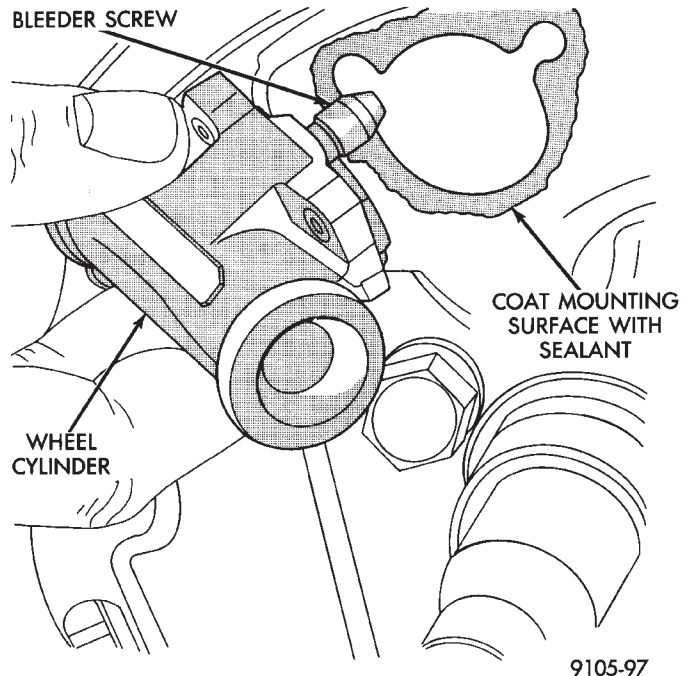

Fig. 2 Remove or Install Wheel Cylinder

To disassemble the wheel cylinders, (Fig. 3) proceed as follows:

- (1) Pry boots away from cylinders and remove.
- (2) Press **IN** on one piston to force out opposite piston, cup and spring (with cup expanders). Then using

a soft tool such as a dowel rod, press out the cup and piston that remain in the wheel cylinder.

(3) Wash wheel cylinder, pistons, and spring in clean brake fluid or alcohol; **(DO NOT USE ANY PETROLEUM BASE SOLVENTS)** clean thoroughly and blow dry with compressed air. Inspect cylinder bore and piston for scoring and pitting. (Do not use a rag as lint from the rag will stick to bore surfaces.)

Wheel cylinder bores and pistons that are badly scored or pitted should be replaced. Cylinder walls that have light scratches, or show signs of corrosion, can usually be cleaned with crocus cloth, using a circular motion. Black stains on the cylinder walls are caused by piston cups and will not impair operation of cylinder.

ASSEMBLING WHEEL CYLINDERS

Before assembling the pistons and new cups in the wheel cylinders, dip them in clean brake fluid. If the boots are deteriorated, cracked or do not fit tightly on the pistons or the cylinder casting, install new boots.

(1) Coat cylinder bore with clean brake fluid.

(2) Install expansion spring with cup expanders in cylinder. Install cups in each end of cylinder with open end of cups facing each other (Fig. 3).

(3) Install piston in each end of cylinder having the flat face of each piston contacting the flat face of each cup, already installed (Fig. 3).

(4) Install a boot over each end of cylinder. **Be careful not to damage boot during installation.**

INSTALLING WHEEL CYLINDERS

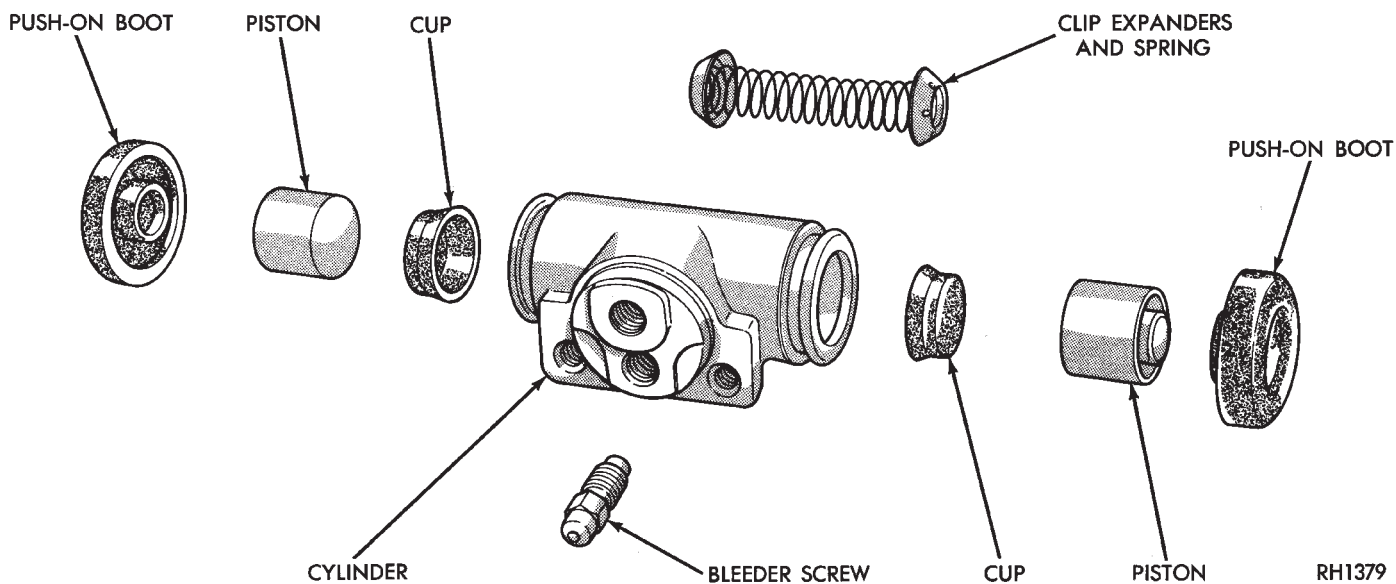

Fig. 3 Rear Wheel Cylinder

(1) Apply Mopar® Gasket In-A-Tube or equivalent sealant around wheel cylinder mounting surface (Fig. 4).

(2) Install wheel cylinder onto brake support, and tighten the wheel cylinder to brake support plate attaching bolts to 8 N•m (75 in. lbs.).

(3) Attach hydraulic brake tube to wheel cylinder, and tighten tube to wheel cylinder fitting to 17 N•m (145 in. lbs.).

(4) Install brake shoes on support plate.

(5) Install rear brake drum onto rear hub. Install rear wheel and tire assembly, tighten wheel stud nuts to 129 N•m (95 ft. lbs.).

(6) Adjust the rear brakes, (See Adjusting Service Brakes) in Service Adjustments section in this group of

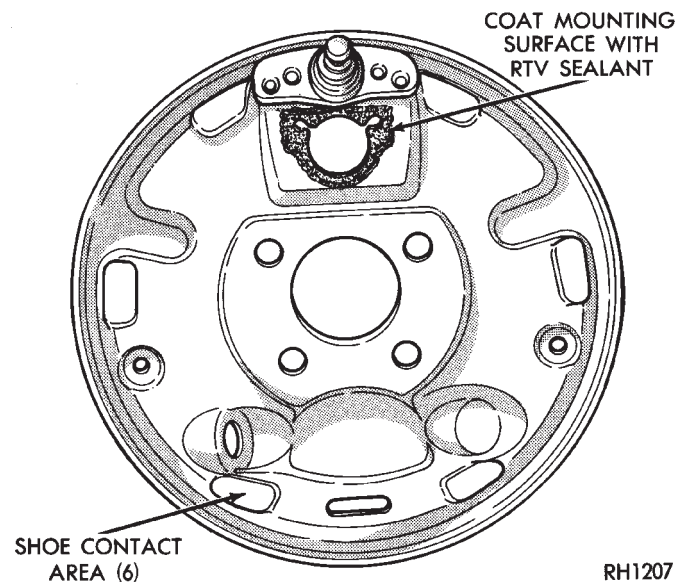

Fig. 4 Apply Sealant on Support Plate

the service manual.

(7) Bleed the entire brake system. See (Bleeding Brake System) in Service Adjustments section in this group of the service manual.

HYDRAULIC SYSTEM CONTROL VALVES

INDEX

ABS Brake Proportioning Valve Operation	29	General Information	28
---	----	-------------------------------	----

GENERAL INFORMATION

All models have a hydraulic system pressure differential warning light switch and a height sensing proportioning valve, in the brake system (Figs. 1 and 3). The switch is attached to the frame rail below the master cylinder (Fig. 2).

PRESSURE DIFFERENTIAL WARNING LIGHT SWITCH

The hydraulic brake system on all vehicles is a diagonally split system. The left front and right rear brakes are part of one system. The right front and left rear are part of another. Both systems are routed through, but hydraulically separated by the Pressure Differential Switch (Fig. 1). The function of the Pressure Differential Switch is to alert the driver of a

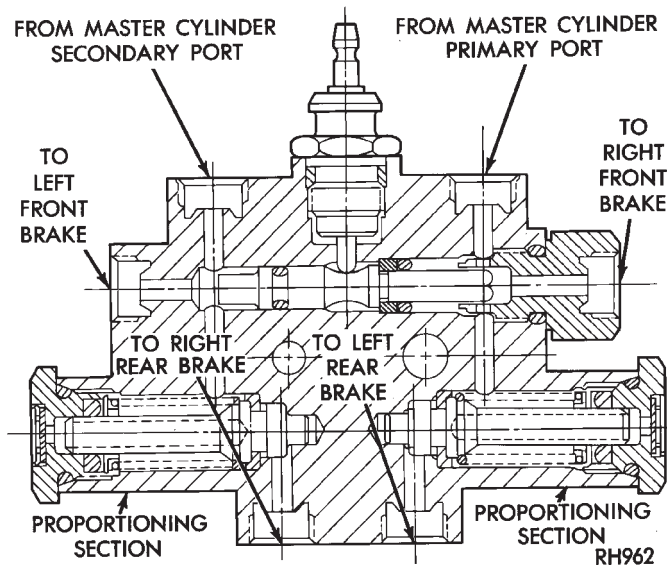

Fig. 1 Pressure Differential Valve And Switch Assembly

malfunction in the brake system.

If hydraulic pressure is lost in one system, the warning light switch (Fig. 2) will activate a red light on the instrument panel, when the brake pedal is depressed. At this point the brakes require service. However, since the brake systems are split diagonally the vehicle will retain 50% of its stopping capability in the event of a failure in either half.

The warning light switch is the latching type. It will automatically center itself after the repair is made and the brake pedal is depressed.

The instrument panel bulb can be checked each time

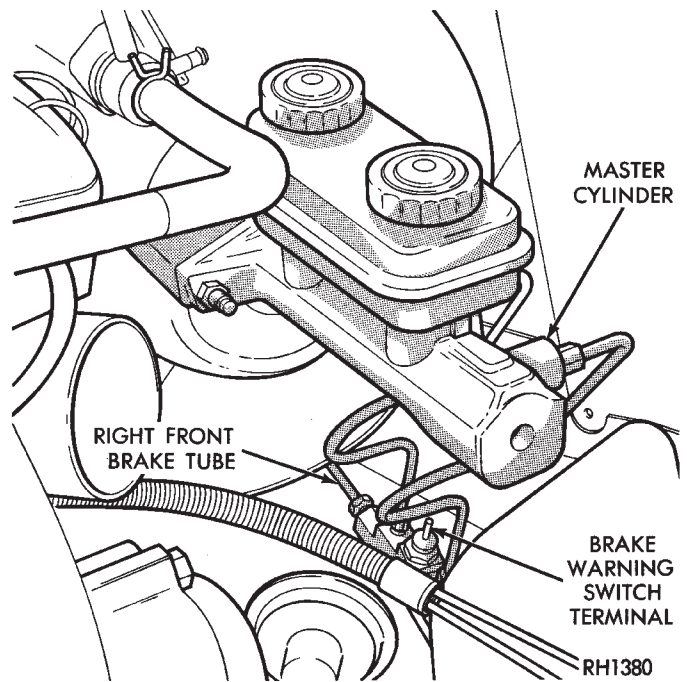

Fig. 2 Brake Warning Switch Location

the ignition switch is turned to the start position or the parking brake is set.

HEIGHT SENSING DUAL PROPORTIONING UNIT OPERATION

These vehicles use a height sensing proportioning valve (Fig. 3) in addition to the pressure differential switch. The height sensing proportioning valve is mounted on the left rear frame rail forward of the spring assembly (Fig. 3). An actuator assembly is connected between the valve lever and a plastic retainer inserted into the actuator bracket.

The height sensing proportioning valve modulates the pressure to the rear brakes, sensing vehicle load condition through movement of the actuator bracket. Optimum front to rear brake balance is maintained regardless of the vehicle load condition. Under a light load condition, line pressure to the rear brakes is minimized. As the load condition increases, so does the pressure to the rear brakes.

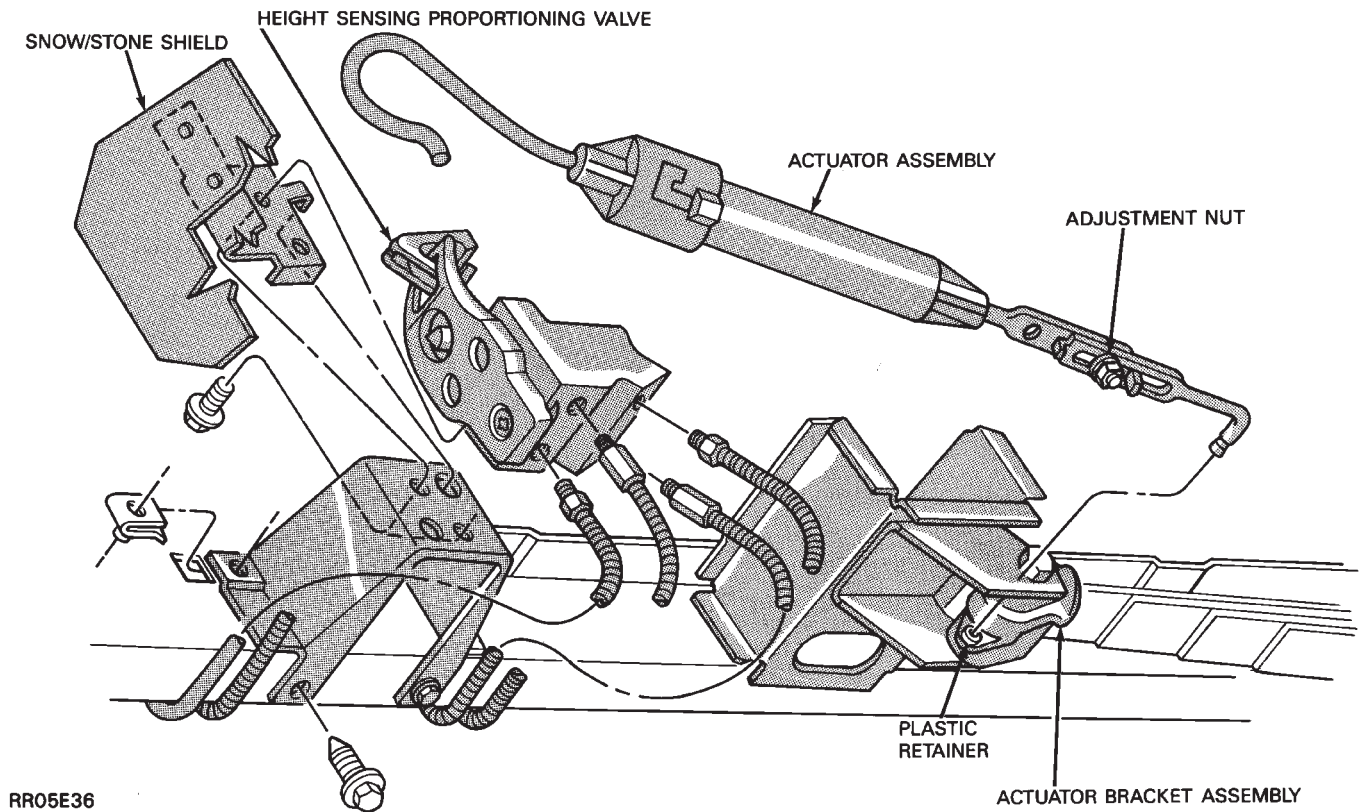

RR05E36

Fig. 3 Height Sensing Proportioning Valve Assembly

CAUTION: The use of after market load leveling or capacity increasing devices are prohibited. Use of air shock absorbers or helper springs will cause the valve to inappropriately reduce the rear brake power potentially resulting in increased stopping distance.

The proportioning valve section operates by transmitting full input pressure to the rear brakes up to a certain point. Called the split point. Beyond that point it reduces the amount of pressure increase to the rear brakes according to a certain ratio.

Thus, on light pedal applications. Approximately equal brake pressure will be transmitted to the front and rear brakes. While at higher pressures, the pressure transmitted to the rear brakes will be lower than to the front brakes. This will prevent premature rear wheel lock-up and skid.

The height sensing proportioning valve changes the split point of the valve, based on vehicle rear suspension height. When the rear height is low, the valve interprets this as extra load and raises the split point to allow more rear braking. When the rear suspension height is high, the split point is lowered and rear braking reduced.

ABS BRAKE PROPORTIONING VALVE OPERATION

On vehicles using the ABS braking system, screw in proportioning valves are used in place of the conventional differential pressure/proportioning valve.

Each rear brake circuit has its own screw-in proportioning valve which is attached to the rear brake outlet ports of the hydraulic assembly. These valves limit brake pressure to the rear brakes after a certain pressure is reached. This improves front to rear brake balance during normal braking.

Screw in proportioning valves can be identified by the numbers stamped on the body of the valve. The first digit represents the slope, the second digit represents the split (cut-in) point, and the arrow represents the flow direction of the valve. **Be sure that the numbers listed on the replacement valve are the as on the valve that is being removed.** See (Fig. 4) for detail of the valve identification.

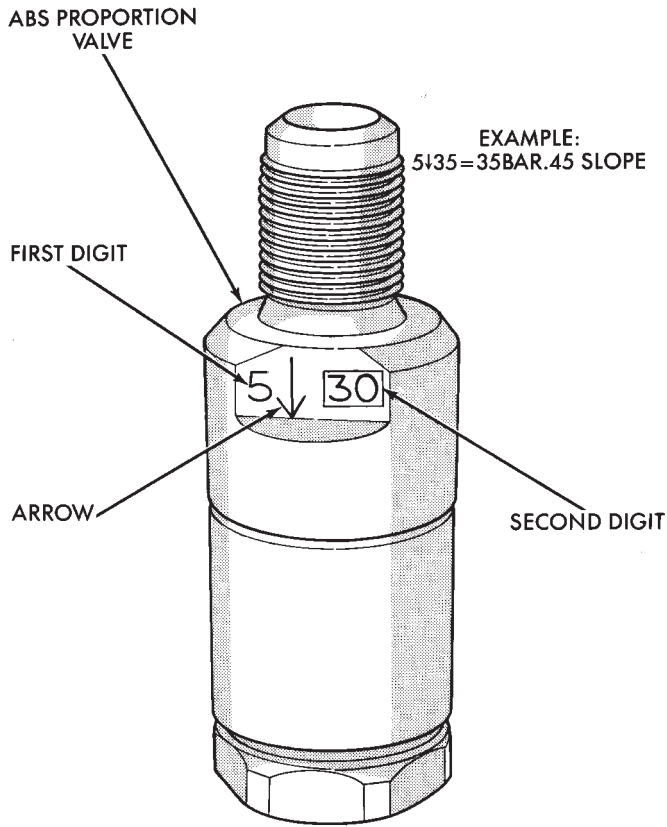

9105-40

Fig. 4 ABS PROPORTIONING VALVE IDENTIFICATION

PROPORTIONING VALVE APPLICATIONS

VEHICLE FAMILY	PROPORTIONING VALVE APPLICATION	VALVE MATERIAL	PROPORTIONING	
			SPLIT	SLOPE
AS BODY	14" DISC--DRUM HEIGHT SENSOR	ALUMINUM	*HSPV	.3
FWD-LWB	15" DISC--DRUM HEIGHT SENSOR	ALUMINUM	*HSPV	.3
FWD-SWB	15" DISC--DRUM ABS SCREW IN	PLATED BLACK	30 BAR 435 PSI	.45
AS BODY	15" DISC--DRUM HEIGHT SENSOR	ALUMINUM	*HSPV	.3
FWD-LWB	15" DISC--DRUM ABS SCREW IN	PLATED BLACK	40 BAR 580 PSI	.45
AS BODY	15" DISC--DRUM HEIGHT SENSOR	ALUMINUM	*HSPV	.3
AWD-SWB	15" DISC--DRUM ABS SCREW IN	PLATED BLACK	20 BAR 290 PSI	.45
AS-BODY	15" DISC--DRUM HEIGHT SENSOR	ALUMINUM	*HSPV	.3
AWD-LWB	15" DISC--DRUM ABS SCREW IN	PLATED BLACK	25 BAR 363 PSI	.45
WHERE 1 BAR IS EQUAL TO 14.5 PSI *HSPV = HEIGHT SENSING PROPORTIONING VALVE				

SERVICE PROCEDURES

INDEX

	page		page
Brake Warning System	1	Testing ABS Proportioning Valves	32
Height Sensing Proportioning Valve	1		

BRAKE WARNING SYSTEM

CHECKING THE BRAKE WARNING SWITCH UNIT

The brake warning light will come on when the parking brake is applied with the ignition key turned ON. The same light will also illuminate should one of the two service brake systems fail.

To test the service brakes warning system. Raise the vehicle on a hoist and open a wheel cylinder bleeder while a helper depresses the brake pedal and observes the warning light. If the light fails to light, inspect for a burned out bulb, disconnected socket, or a broken or disconnected wire at the switch. If the bulb is not burned out and the wire continuity is uninterrupted. Check the service brake warning switch operation with a test lamp between the switch terminal and a known good vehicle ground. Be sure to fill master cylinder and bleed brake system after correction has been made, if necessary.

HEIGHT SENSING PROPORTIONING VALVE

TESTING THE HEIGHT SENSING VALVE UNIT

When a premature rear wheel skid is obtained on brake application it could be an indication that the fluid pressure to the rear brakes is above the desired output and that a malfunction may have occurred within the proportioning valve unit and that the valve should be tested.

Prior to testing proportioning valve operation, ensure the front and rear brake linings are in satisfactory condition. It is also necessary to verify brakes on vehicle being tested are original equipment manufacturers (OEM), original or replacement brake shoe assemblies. The vehicles brake system is not balanced for after market brake shoe assembly lining material.

If brake shoe assembly lining material is of satisfactory condition, proceed to verify that height sensing proportioning valve actuator is properly adjusted. See Installation and Adjustment paragraph steps 1 through 6. If adjustment is satisfactory then proceed with the proportioning valve test.

To test the proportioning valve, proceed as follows:

(1) Loosen and remove the actuator assembly adjustment nut (Fig. 2 or 4). Disconnect the assembly from the valve lever and remove.

(2) Install one gauge and T of set C-4007-A in the line from either master cylinder port to the brake valve assembly.

(3) Install the second gauge of set C-4007-A to either rear brake outlet port between proportioning valve assembly and the rear brake line. Bleed both hydraulic circuits and the gauges.

(4) Have a helper exert pressure on the brake pedal (holding pressure) to get a reading on the valve inlet gauge and check the reading on the outlet gauge. The inlet pressure should be 3445 kPa (500 psi) and the outlet pressure should be 689 to 780 kPa (100-200 psi). If not, replace the valve and tighten mounting bolts to 28 N•m (250 in. lbs.) torque. If the valve tests OK install actuator assembly, adjust and **road test vehicle**.

INSTALLATION AND ADJUSTMENT (FIG. 4)

After installing a new height sensing proportioning valve, bleed both hydraulic circuits at the rear brakes.

The rubber stone/snow shield must be installed whenever the valve is serviced. This shield protects the valve and hydraulic lines from stone impact and the packing of snow and slush.

(1) Lift vehicle with a frame contact hoist or other means so that the rear suspension is hanging free with the shock absorbers disconnected from the axle. Remove the tires and wheels from the rear axle. **Be sure that the rear springs do not contact the hoist, or an improper adjustment may result.** Loosen both front spring hanger pivot bolts.

(2) Loosen adjustment nut on the actuator assembly (Fig. 4). Before adjustment, be sure that actuator assembly hook is properly seated on valve lever.

(3) Pull actuator assembly toward the spring hanger until the valve lever bottoms on the valve body, hold in this position.

(4) Tighten the adjustment nut to 5 N•m (25 in. lbs.) torque. Adjustment is now complete.

(5) Install wheel and tires and connect shock absorbers.

(6) **Lower vehicle to floor and with full weight of vehicle on the wheels,** tighten both front spring hanger pivot bolts to 129 N•m (95 ft. lbs.) torque. Road test vehicle.

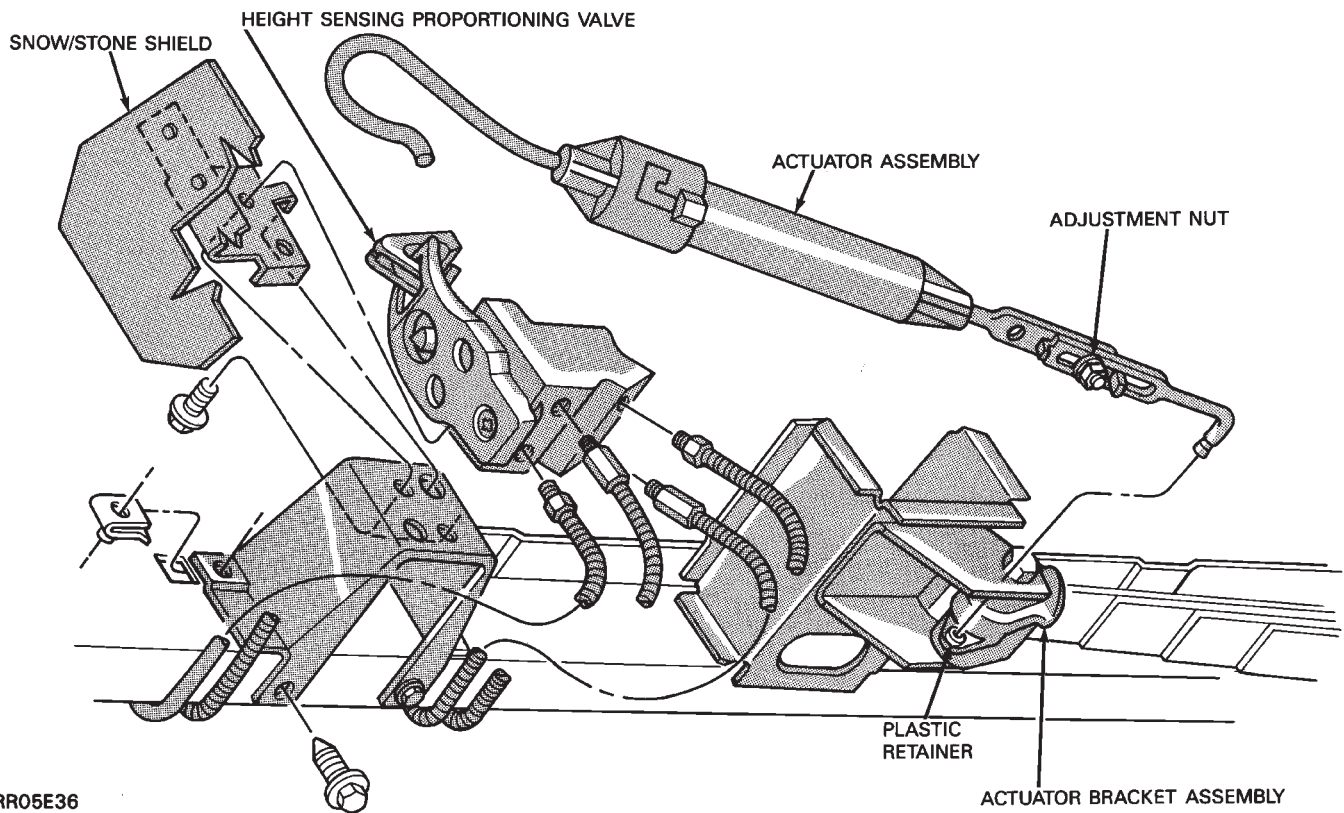

RR05E36

Fig. 4 Height Sensing Proportioning Valve Assembly

TESTING ABS PROPORTIONING VALVES

All A.B.S. components use an ISO flare. Use the correct adapters when installing gauges.

- (1) Install one gauge and (T) between the hydraulic assembly and the male end (Inlet) of the valve.
- (2) Install the second gauge at the female end (Outlet) of the valve (Fig. 5).
- (3) Have a helper exert pressure on the brake pedal (holding pressure) to get a reading on the valve inlet gauge.
- (4) Check the reading on the outlet gauge. If the inlet and outlet pressures do not agree with the follow-

ing chart, replace the valve. See (Fig. 4) in Hydraulic Control Valves Section for ABS proportioning valve identification.

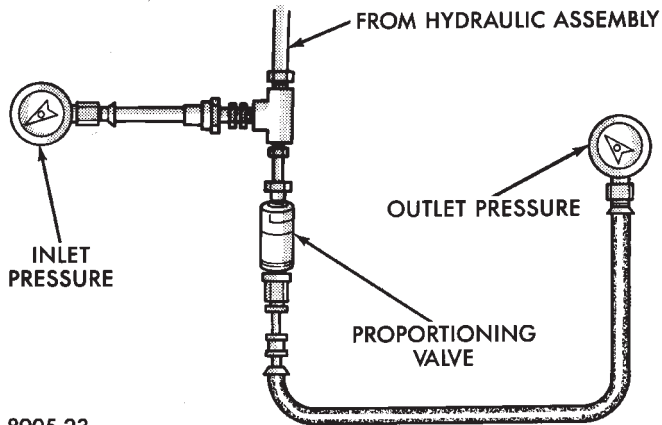

8905-23

Fig. 5 Tube Connections for ABS

PROPORTIONING VALVE PRESSURES ABS-BRAKES

Proportioning Valve	Slope	Inlet Pressure PSI	Output Pressure PSI
20 BAR*	.45	1000 PSI	560 PSI – 640 PSI
25 BAR	.45	1000 PSI	600 PSI – 680 PSI
30 BAR	.45	1000 PSI	640 PSI – 720 PSI
35 BAR	.45	1000 PSI	685 PSI – 765 PSI
40 BAR	.45	1000 PSI	725 PSI – 805 PSI
45 BAR	.45	1000 PSI	765 PSI – 845 PSI
20 BAR	.3	1000 PSI	460 PSI – 540 PSI
25 BAR	.3	1000 PSI	510 PSI – 590 PSI
30 BAR	.3	1000 PSI	560 PSI – 640 PSI
35 BAR	.3	1000 PSI	610 PSI – 690 PSI
40 BAR	.3	1000 PSI	660 PSI – 740 PSI
45 BAR	.3	1000 PSI	715 PSI – 795 PSI

*WHERE 1 BAR IS EQUAL TO 14.5 PSI

DISC BRAKES

INDEX

	page		page
General Information	33	Service Precautions	35

GENERAL INFORMATION

The single piston, floating caliper disc brake assembly (Fig. 1 and 2) consists of:

- The driving hub.
- Braking disc (rotor).
- Caliper assembly.
- Shoes and linings.
- Adapter for mounting the caliper assembly to the steering knuckle.

The double pin Kelsey-Hayes family caliper, is mounted to the adapter using bushings and sleeves and 2 through bolts threaded into the adapter (Fig. 3)

Two machined abutments on the adapter, position and align the caliper fore and aft. The guide pins and bushings control the side to side movement of the caliper. The piston seal, is designed to assist in maintaining proper brake shoe to braking disc (rotor) clearance.

The Kelsey-Hayes double pin family caliper has one anti-rattle clip attached to the top of the adapter (Fig. 1).

All of the braking force is taken directly by the adapter and the steering knuckle.

The caliper is a one piece casting with the inboard side containing a single piston cylinder bore.

The phenolic piston is 60 mm (2.36 inch) in diameter. A square cut rubber piston seal is located in a machined groove in the cylinder bore. It provides a hydraulic seal between the piston and the cylinder wall (Fig. 4).

A molded rubber dust boot installed in a groove in the cylinder bore and piston, keeps contamination from the cylinder wall and piston.

The dust boot mounts in a counter bore of the cylinder bore opening and in a groove which is machined in the outer surface of the piston (Fig. 4). This prevents contamination of the piston and the bore area.

As lining wears, reservoir level will go down. If fluid has been added, reservoir overflow may occur when the piston is pushed back into the new lining position. Overflowing can be avoided by removing a small amount of fluid from the master cylinder reservoir.

SHOE AND LINING WEAR

If a visual inspection does not adequately determine the condition of the lining, a physical check

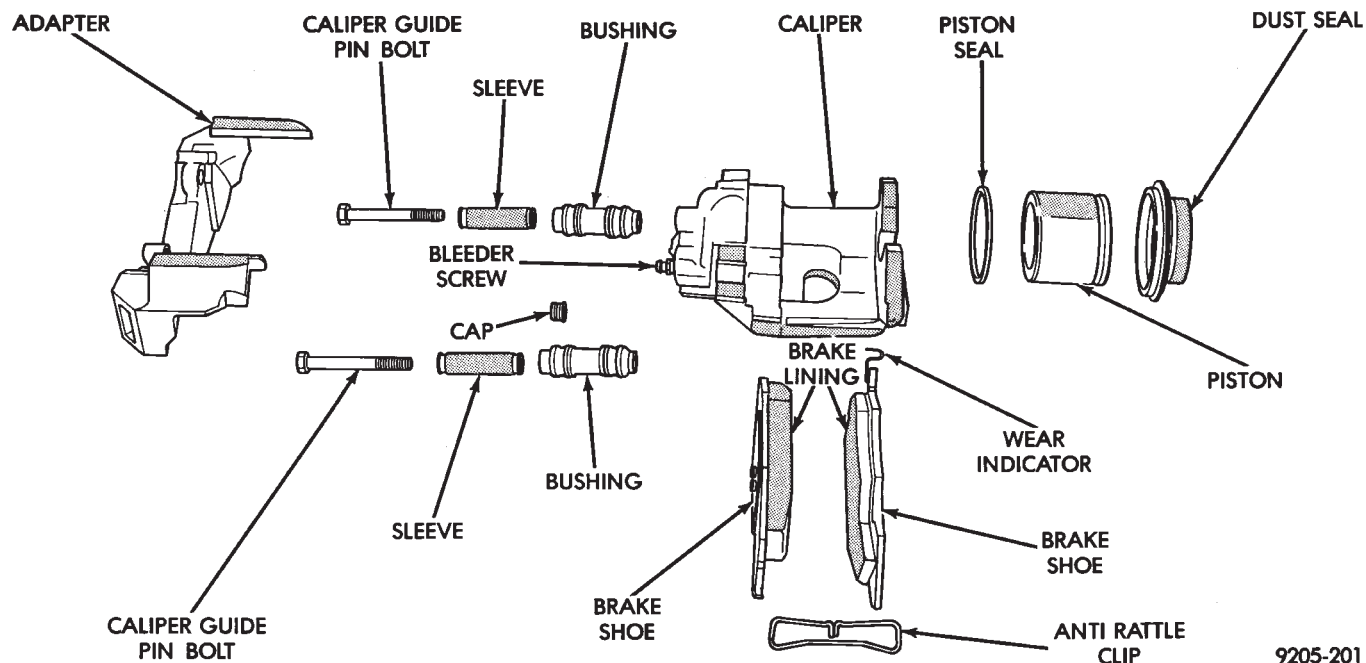
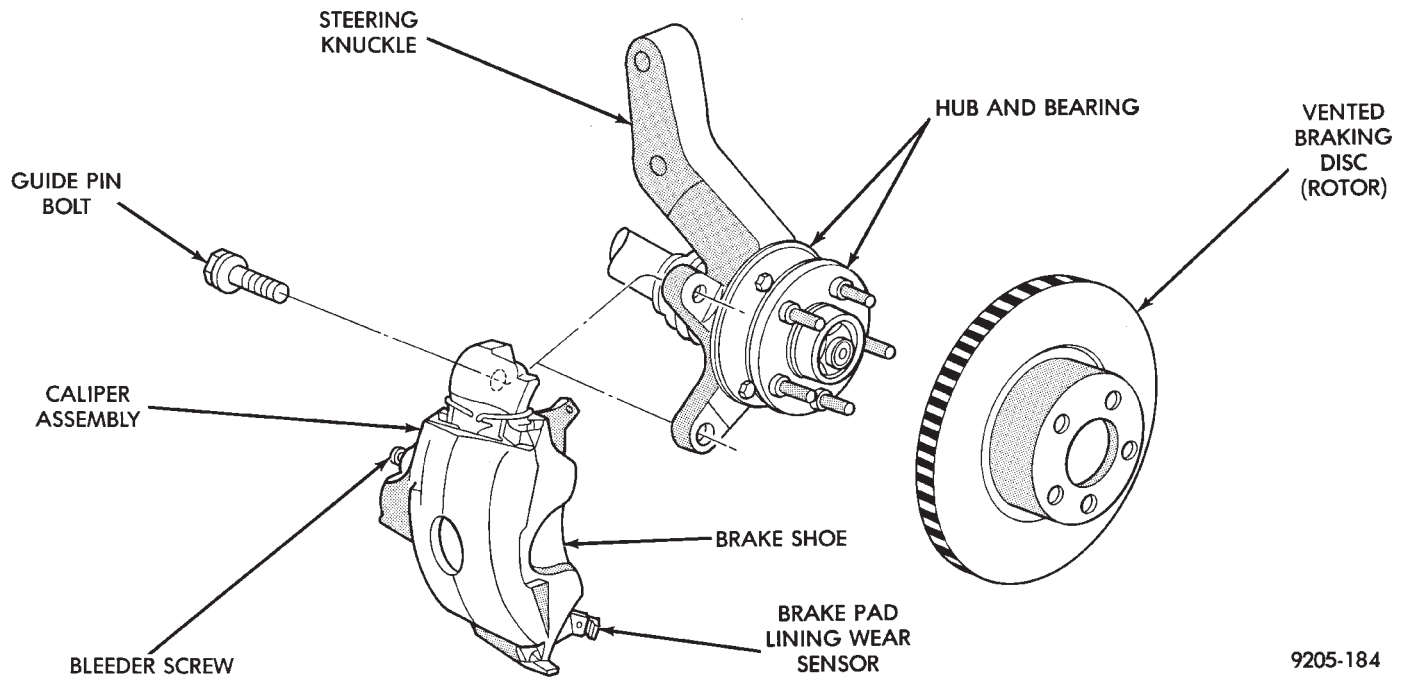
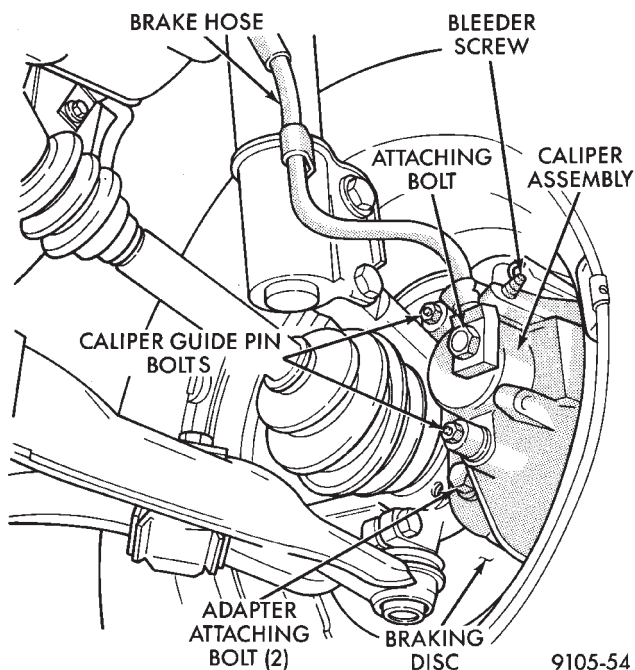

Fig. 1 Disk Brake Caliper Assembly (Family Caliper)



9205-184

Fig. 2 Front Disc Brake Assembly



9105-54

Fig. 3 Disc Brake Caliper Mounting

will be necessary. To check the amount of lining wear, remove the wheel and tire assemblies, and the calipers.

Remove the shoe and lining assemblies. (See Brake Shoe Removal).

Combined shoe and lining thickness should be measured at the thinnest part of the brake shoe assembly.

When a shoe and lining assembly is worn to a thickness of approximately 7.95 mm (0.313 inch) it should be replaced.

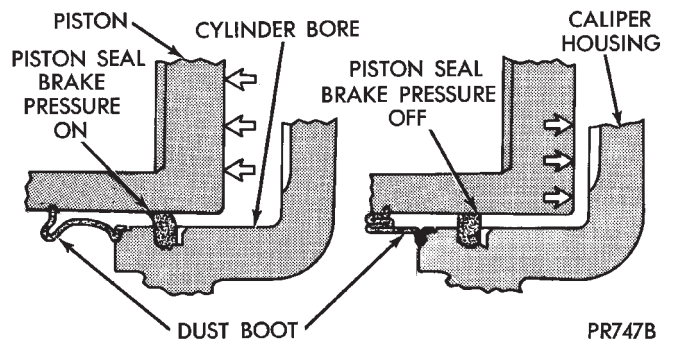

PR747B

Fig. 4 Caliper Piston Seal Function for Automatic Adjustment

Replace **both** shoe assemblies (inboard and out-board) on the front wheels. It is also necessary that **both** front wheel brake shoe assembly sets be replaced, whenever shoe assemblies on either side of the vehicle require replacement.

If a shoe assembly does not require replacement, reinstall it, making sure each shoe assembly is returned to its original position. (See Brake Shoe Installation).

SERVICE PRECAUTIONS

WARNING: DUST AND DIRT ON BRAKE PARTS GENERATED DURING THE NORMAL USE AND WEAR OF MOTOR VEHICLE BRAKE SYSTEMS CAN CONTAIN ASBESTOS FIBERS. BREATHING EXCESSIVE CONCENTRATIONS OF ASBESTOS FIBERS CAN CAUSE SERIOUS BODILY HARM, SUCH AS ASBESTOSIS AND CANCER. EXTREME CARE SHOULD BE EXERCISED WHILE SERVICING BRAKE ASSEMBLIES OR COMPONENTS.

DO NOT CLEAN BRAKE ASSEMBLIES OR COMPONENTS WITH COMPRESSED AIR OR BY DRY BRUSHING; USE A VACUUM CLEANER SPECIFICALLY RECOMMENDED FOR USE WITH ASBESTOS FIBERS. IF A SUITABLE VACUUM CLEANER IS NOT AVAILABLE, CLEANING SHOULD BE DONE WET USING A WATER DAMPENED CLOTH.

DO NOT CREATE DUST BY SANDING, GRINDING, AND/OR SHAVING BRAKE LININGS OR PADS UNLESS SUCH OPERATION IS DONE WHILE USING PROPERLY EXHAUST VENTILATED EQUIPMENT.

DISPOSE OF DUST AND DIRT SUSPECTED TO CONTAIN ANY ASBESTOS FIBERS IN SEALED BAGS

KELSEY HAYES DOUBLE PIN FAMILY CALIPER

OR CONTAINERS TO MINIMIZE DUST EXPOSURE TO YOURSELF AND OTHERS.

FOLLOW ALL RECOMMENDED PRACTICES PRESCRIBED BY THE OCCUPATIONAL SAFETY AND HEALTH ADMINISTRATION AND THE ENVIRONMENTAL PROTECTION AGENCY. FOR THE HANDLING, PROCESSING, AND DISPOSITION OF DUST OR DIRT WHICH MAY CONTAIN ASBESTOS FIBERS.

Grease or any other foreign material must be kept off the caliper assembly, surfaces of the braking disc and external surfaces of the hub, during service procedures.

Handling of the braking disc and caliper should be done in such a way as to avoid deformation of the disc and scratching or nicking the brake linings (pads).

If inspection reveals that the square sectioned caliper piston fluid seal is worn or damaged, it should be replaced immediately.

During removal and installation of a wheel and tire assembly, be careful not to strike the caliper.

Before vehicle is moved after any brake service work, be sure to obtain a firm brake pedal.

INDEX

	page		page
Assembling Caliper	40	Disassembling Caliper	38
Brake Shoe Installation	37	Service Procedures	35
Cleaning and Inspection	39		

SERVICE PROCEDURES

BRAKE SHOE REMOVAL

(1) Raise vehicle on jackstands or centered on a hoist. See Hoisting in the Lubrication and Maintenance section of this manual.

(2) Remove front wheel and tire assemblies.

(3) Remove caliper guide pin bolts (Fig. 1).

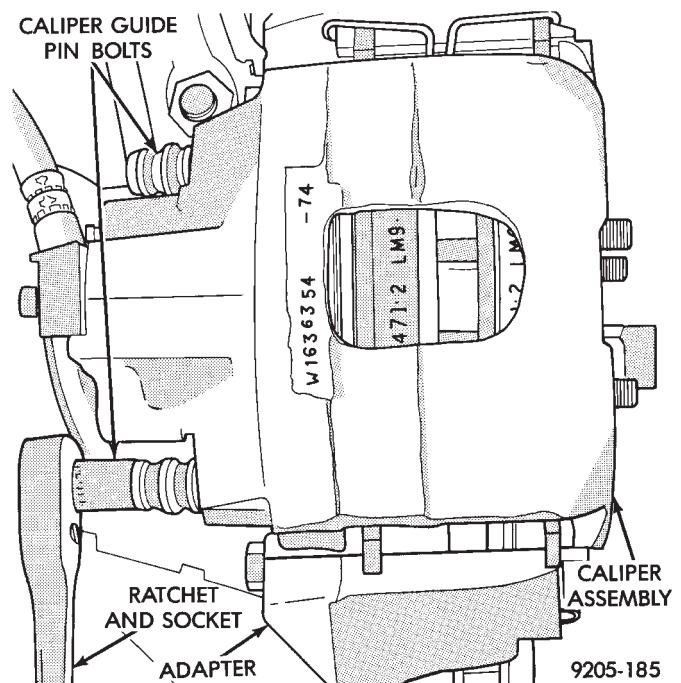

Fig. 1 Removing or Installing Caliper Guide Pin Bolts



(4) After removing the caliper guide pin bolts. Pry the caliper away from the braking disc with a pry bar or screwdriver (Fig. 2).

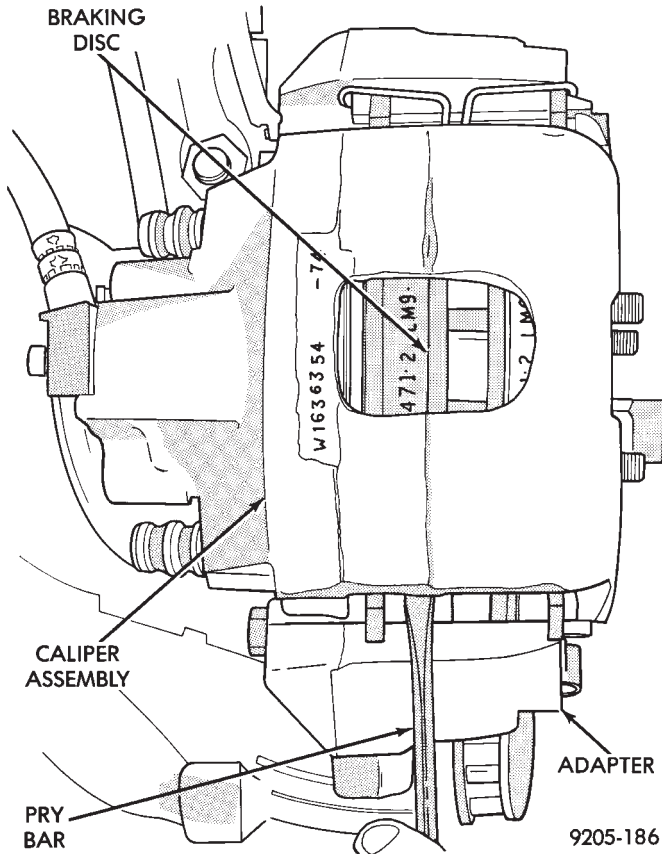

Fig. 2 Loosening Family Caliper Assembly From Adapter And Rotor

(5) Remove caliper assembly from braking disc and adapter by sliding the assembly out and away from the braking disc and adapter (Fig. 3).

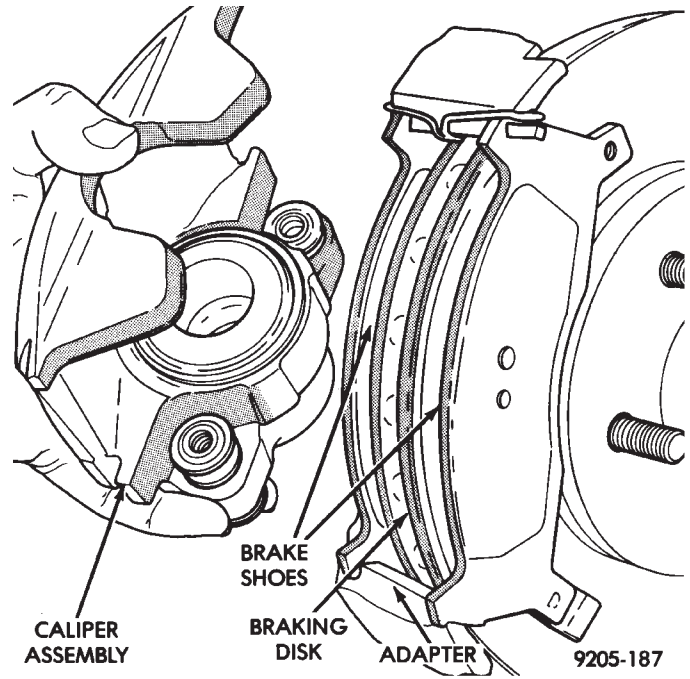

Fig. 3 Removing or Installing Caliper Assembly

(6) Support caliper firmly to prevent weight of caliper from damaging the flexible brake hose (Fig. 4).

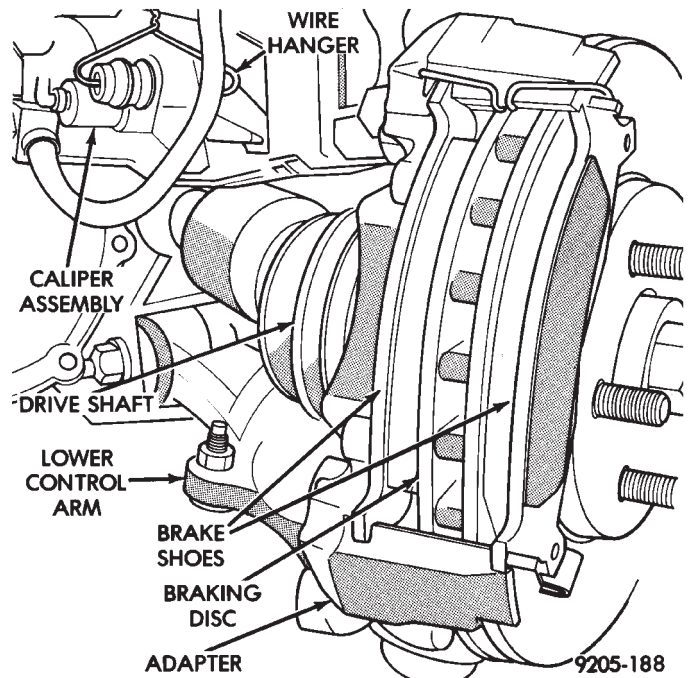

Fig. 4 Storing Caliper



(7) Remove the outboard brake shoe assembly from the caliper adapter (Fig. 5).

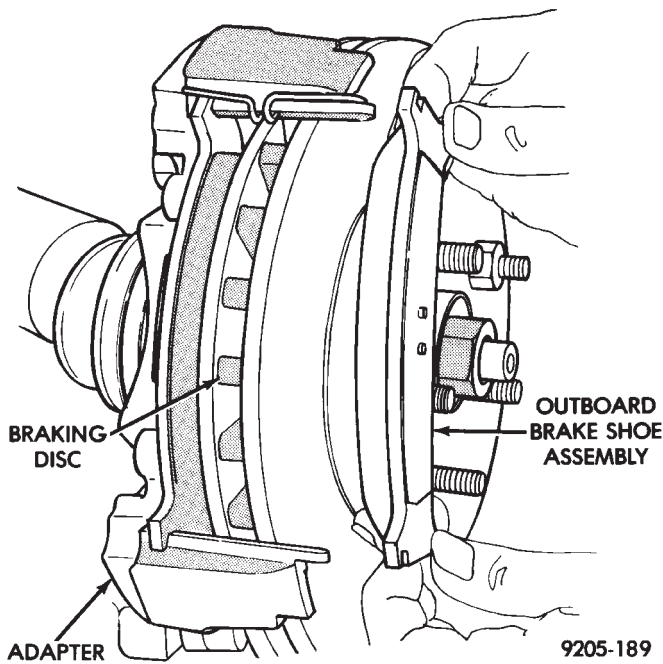

Fig. 5 Removing and Installing Outboard Shoe Assembly

(8) Remove the braking disk (rotor) from the hub by pulling it straight off the wheel mounting studs (Fig. 6).

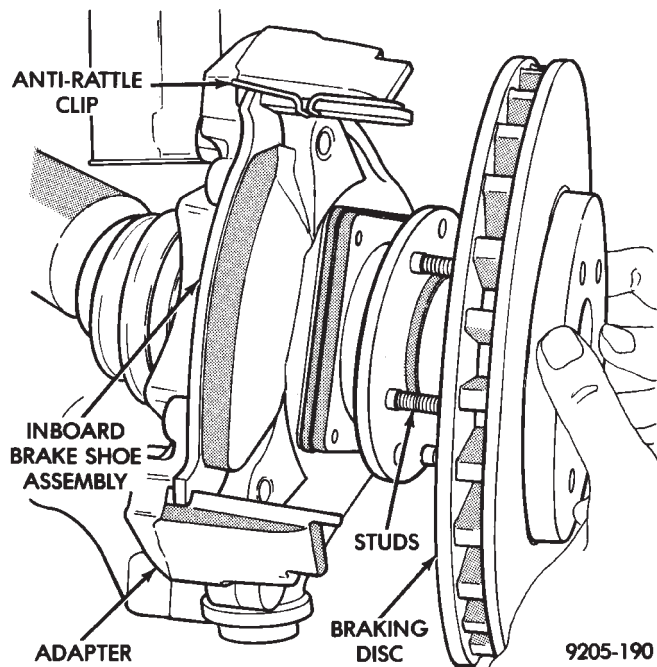

Fig. 6 Removing or Installing Braking Disc

(9) Remove the inboard brake shoe assembly by sliding it out along the bottom adapter abutment until brake shoe assembly loosens from anti-rattle clip (Fig. 7).

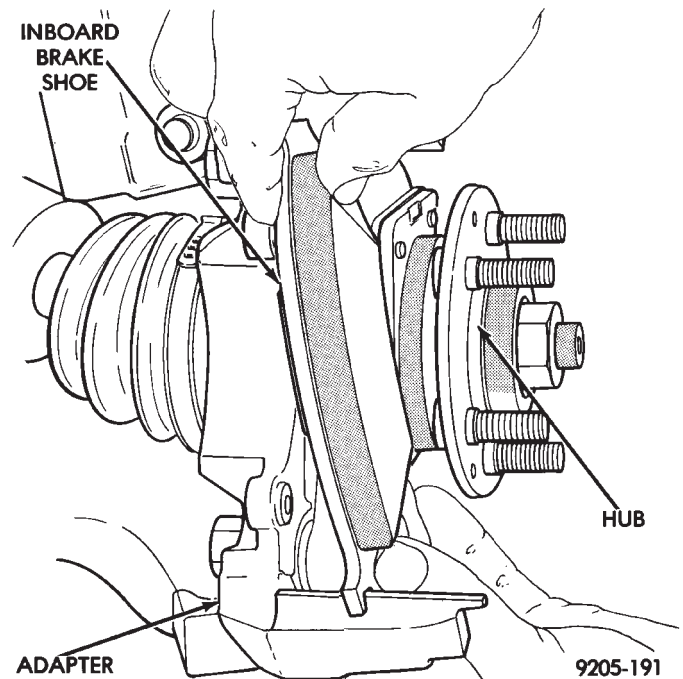

Fig. 7 Removing or Installing Inboard Shoe Assembly

(10) Remove the anti-rattle clip from the top adapter abutment (Fig. 8).

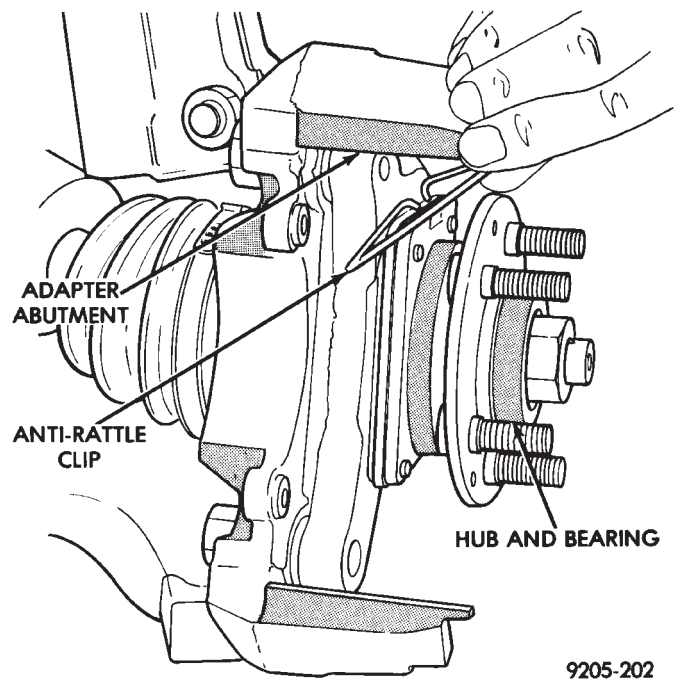

Fig. 8 Remove Or Replace Anti-Rattle Clip

BRAKE SHOE INSTALLATION

(1) Lubricate both adapter abutments with a liberal amount of Mopar® Multipurpose Lubricant, or equivalent.

(2) Install the anti-rattle clip on the upper abutment of the caliper mounting adapter (Fig. 8).

(3) Remove the protective paper from the noise suppression gasket on both the inner and outer brake shoe assemblies (if equipped).

(4) Install the new inboard brake shoe assembly on the adapter by sliding it along the adapter abutments. Be careful not to get any grease from the adapter abutment on the surface of the brake lining material, (Fig. 7). Be sure inboard brake shoe assembly is correctly positioned against anti-rattle clip (Fig. 6).

(5) Reinstall the Braking Disk on the hub, by installing it over the wheel studs until it is seated against the face of the hub (Fig. 6).

(6) Slide the new outboard brake shoe assembly on the adapter abutment, (Fig. 5).

(7) Carefully lower caliper over the braking disk and brake shoe assemblies (Fig. 3). Make sure that the caliper guide pin bolt, bushings and sleeves are clear of the adapter.

(8) Install the caliper guide pin bolts and tighten to 34 to 37 N•m (25 to 35 ft. lbs.). **Extreme caution should be taken not to cross the threads of the caliper guide pin bolts.**

(9) Install the wheel and tire assembly. Tighten the wheel mounting stud nuts in proper sequence (Fig. 9) until all nuts are torqued to half specification. This is important. Then repeat the tightening sequence to the full specified torque of 129 N•m (95 ft. lbs.).

(10) Remove jackstands or lower hoist. **Before moving vehicle, pump the brake pedal several times**

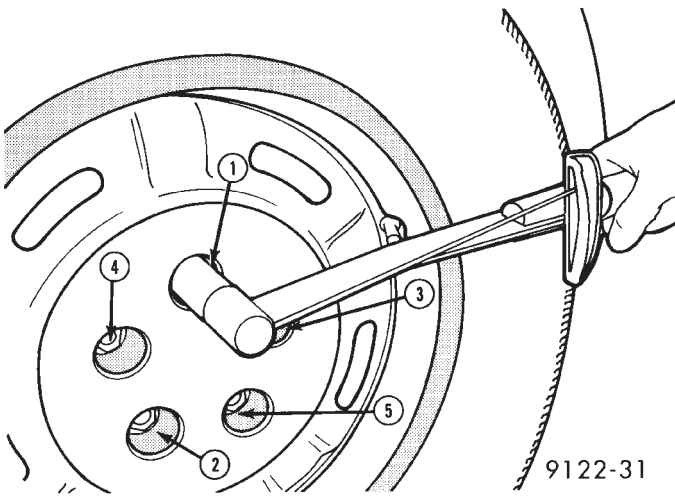

Fig. 9 Tightening Wheel Nuts

to insure the vehicle has a firm brake pedal to adequately stop vehicle..

Road test the vehicle and make several stops to wear off any foreign material on the brakes and to seat the brake shoe linings.

CLEANING AND INSPECTION

Check for piston fluid seal leaks (brake fluid in and around boot area and inboard lining) and for any ruptures of piston dust boot. If boot is damaged, or fluid leak is visible, disassemble caliper assembly and in-

stall a new seal and boot, (and piston if scored). Refer to procedures titled Disassembling Caliper.

Check the caliper dust boot and caliper pin bushings to determine if they are in good condition. Replace if they are damaged, dry, or found to be brittle. Refer to Caliper Service.

DISASSEMBLING CALIPER

(1) Remove caliper from braking disc (See Brake Shoe Removal). Hang assembly on a wire hook away from braking disc, so hydraulic fluid cannot get on braking disc (See Fig. 4 in Brake Shoe Removal). Place a small piece of wood between the piston and caliper fingers.

(2) **Carefully** depress brake pedal to hydraulically push piston fully out of bore. (Brake pedal will fall away when piston has passed bore opening.) Then prop up the brake pedal to any position below the first inch of pedal travel, this will prevent loss of brake fluid from the master cylinder.

(3) If both front caliper pistons are to be removed, disconnect flexible brake line at frame bracket after removing piston. Plug brake tube and remove piston from opposite caliper. Using the same process as above for the first piston removal.

WARNING: UNDER NO CONDITION SHOULD AIR PRESSURE BE USED TO REMOVE PISTON FROM CALIPER BORE. PERSONAL INJURY COULD RESULT FROM SUCH A PRACTICE.

(4) Disconnect brake flexible hose from the caliper. To disassemble, mount caliper assembly in a vise equipped with protective jaws.

CAUTION: Excessive vise pressure will cause bore distortion and binding of piston.

Support caliper and remove dust boot and discard (Fig. 1).

Using a plastic trim stick, work piston seal out of its groove in caliper piston bore (Fig. 2). Discard old seal. **Do not use a screwdriver or other metal tool for this operation, because of the possibility of scratching piston bore or burring edges of seal groove.**

The double pin caliper uses a sealed for life bushing and sleeve assembly. If required this assembly can be serviced using the following procedure.

(1) Push out and then pull the inner sleeve from inside of the bushing using your fingers as shown in (Fig. 3)

(2) Using your fingers collapse one side of the bushing. Then pull on the opposite side to remove the bushing from the caliper assembly (Fig. 4).

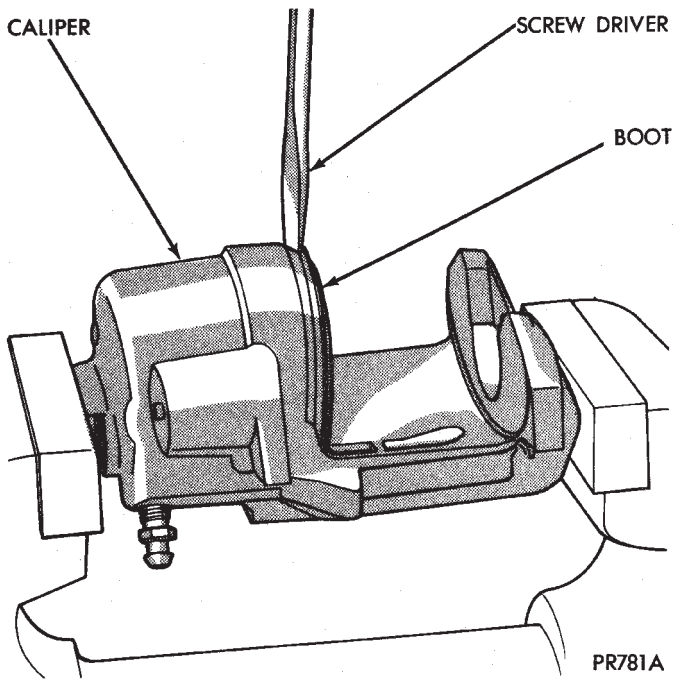

Fig. 1 Removing Piston Dust Boot

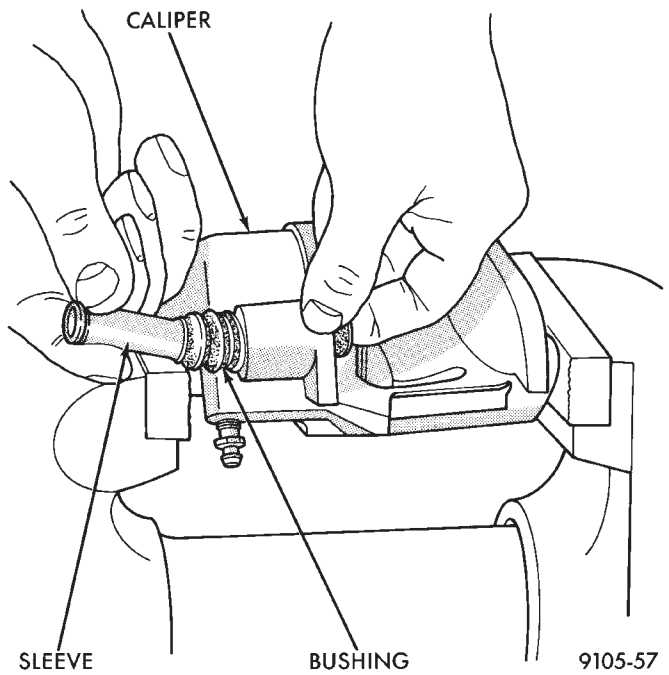

Fig. 3 Removing Inner Sleeve

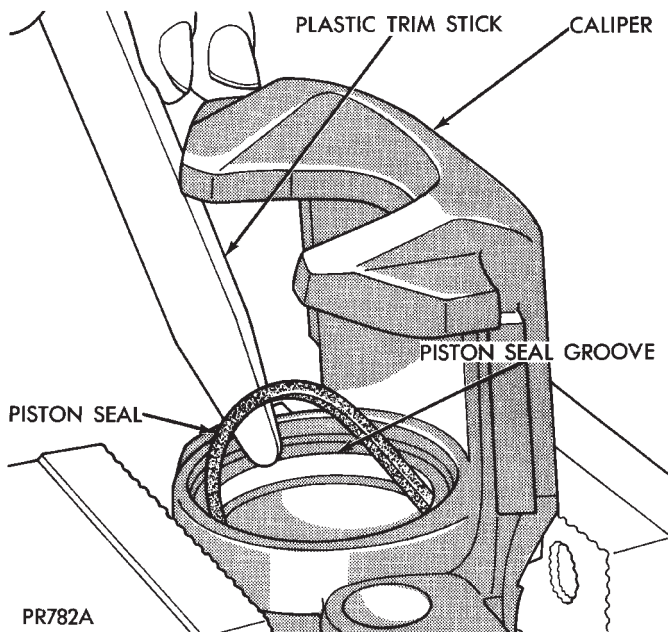

Fig. 2 Removing Piston Seal

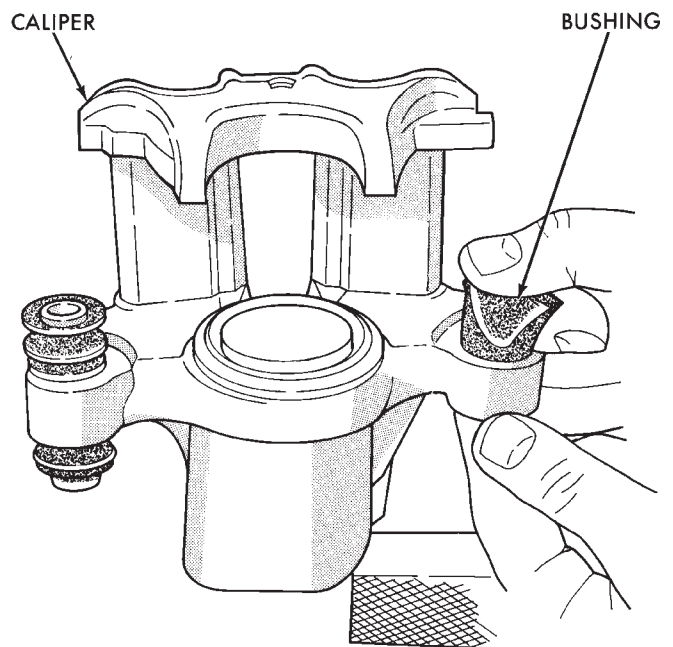

Fig. 4 Removing Bushings From Caliper

CLEANING AND INSPECTION

Clean all parts using alcohol or a suitable solvent and wipe dry. Clean out all drilled passages and bores. **(Whenever a caliper has been disassembled, a new boot and seal must be installed at assembly).**

Inspect the piston bore for scoring or pitting. Bores that show light scratches or corrosion, can usually be cleared with crocus cloth.

Bores that have deep scratches or scoring should be honed. Use Caliper Hone, Special Tool C-4095, or equivalent providing the diameter of the bore is not increased more than 0.0254 mm (0.001 inch) (Fig. 5).

If the bore does not clean up within this specification, a new caliper housing should be installed. Install a new piston if the old one is pitted or scored.

When using Caliper Honing Tool, Special Tool C-4095, coat the stones and bore with brake fluid. After honing the bore, carefully clean the seal and boot grooves with a stiff non-metallic rotary brush.

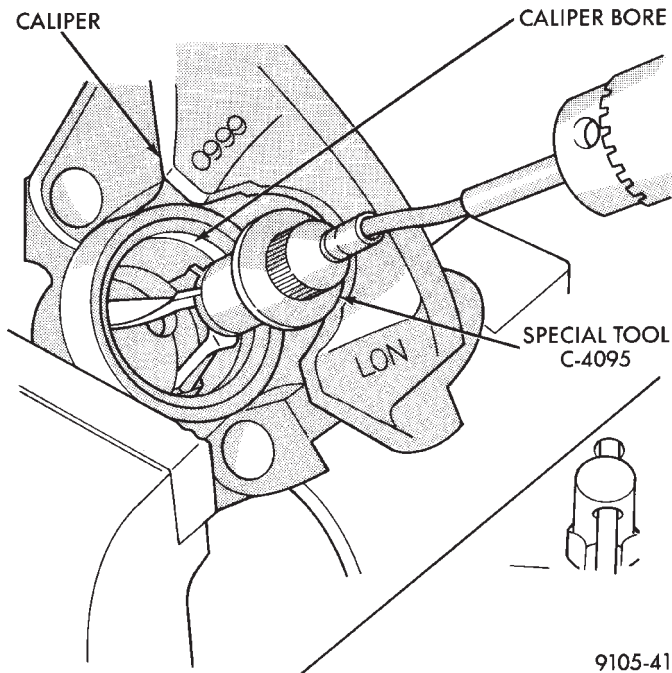

Fig. 5 Honing Piston Bore

9105-41

Use extreme care in cleaning the caliper after honing. Remove all dirt and grit by flushing the caliper with brake fluid; wipe dry with a clean, lint free cloth and then clean a second time.

ASSEMBLING CALIPER

Clamp caliper in vise (with protective caps on vise jaws).

CAUTION: Excessive vise pressure will cause bore distortion and binding of piston.

Dip new piston seal in clean brake fluid and install in the groove of the caliper bore. Seal should be positioned at one area in groove and gently worked around the groove (Fig. 1), using only your fingers until properly seated.

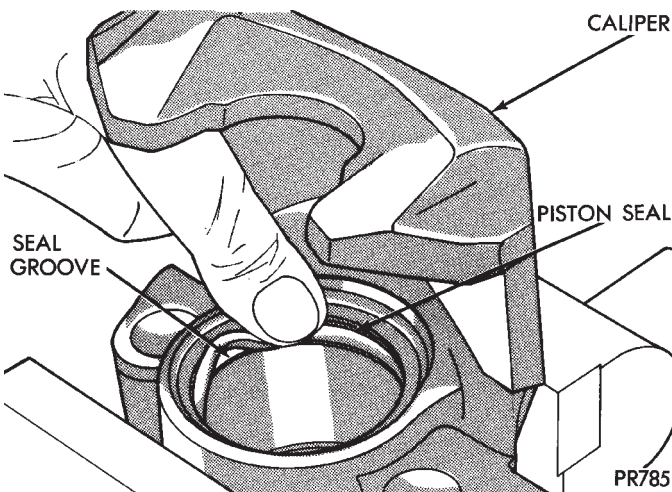

Fig. 1 Installing New Piston Seal

PR785

NEVER USE AN OLD PISTON SEAL. (Be sure that fingers are clean and seal is not twisted or rolled) (Fig. 1).

Coat new piston boot with clean brake fluid leaving a generous amount inside boot.

Position dust boot over piston after coating with brake fluid.

Install piston into caliper bore pushing it past the piston seal until it bottoms in the caliper bore (Fig. 2).

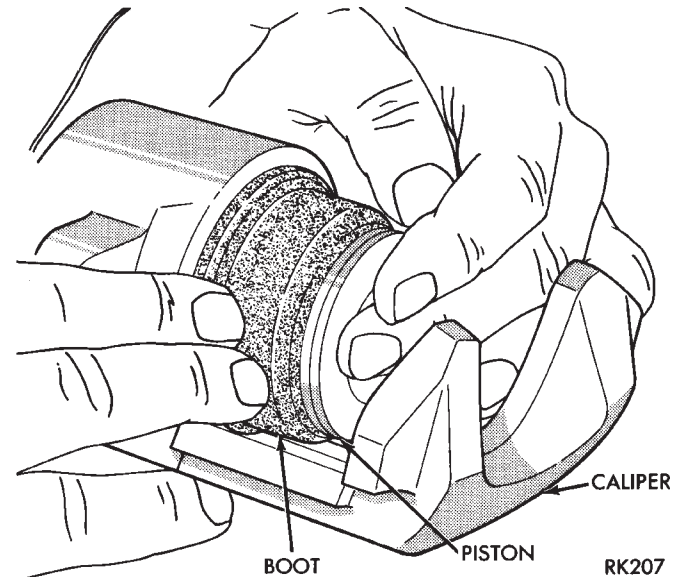

Fig. 2 Pushing Piston into Bore

CAUTION: Force must be applied to the piston uniformly to avoid cocking and binding of the piston in the bore of the caliper.

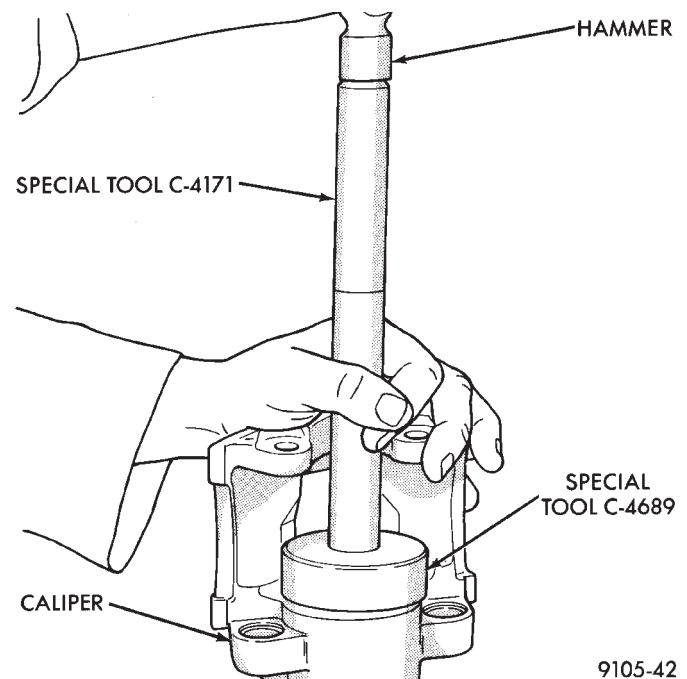
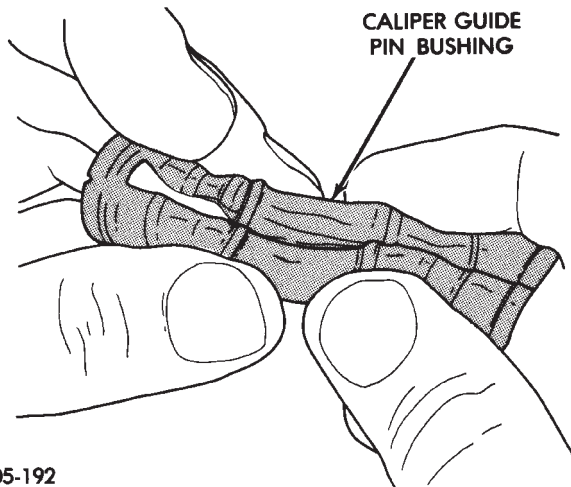

Fig. 3 Installing Dust Boot in Caliper Counterbore

9105-42



9205-192

Fig. 4 *Folded Caliper Guide Pin Bushing*

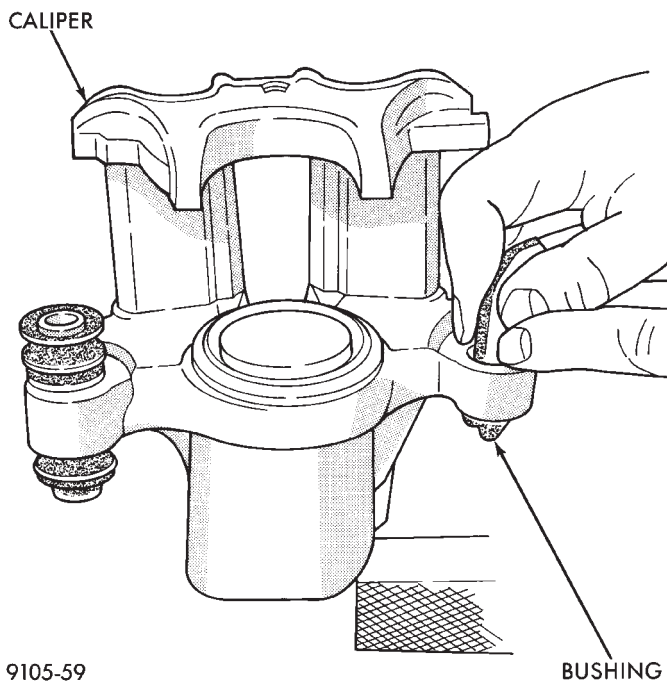

9105-59

Fig. 5 *Installing Caliper Guide Pin Sleeve Bushings*

Position dust boot in counterbore of the caliper piston bore.

Using a hammer and Installer Piston Caliper Boot, Special Tool C-4689 and Handle, Special Tool C-4171, drive boot into counterbore of the caliper (Fig. 3).

Use the following steps, to install the Guide Pin Sleeve Bushings into the caliper assembly.

(1) Fold the bushing in half lengthwise at the solid middle section of the bushing (Fig. 4).

(2) Using your fingers insert the folded bushing into the caliper assembly (Fig. 5). **Do not use a sharp object to perform this step do to possible damage to the bushing.**

(3) Unfold the bushing using your fingers or a wooden dowel until the bushing is fully seated into the

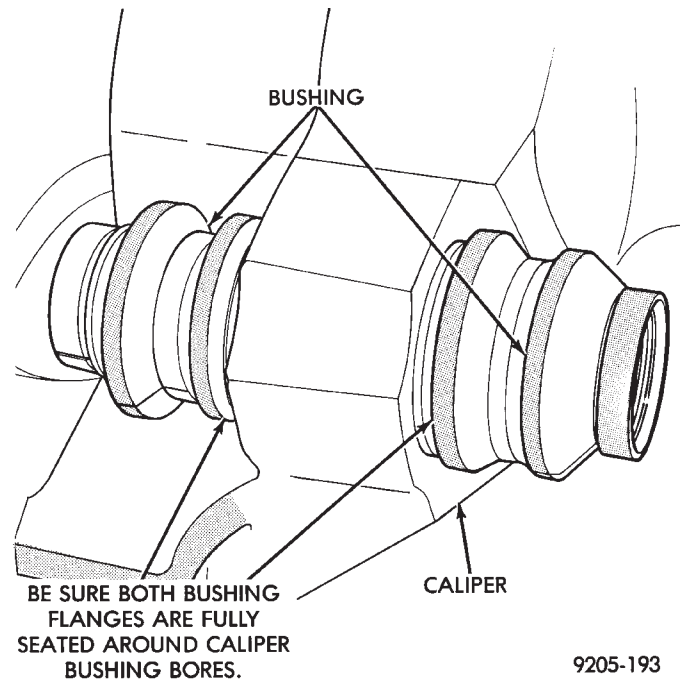

9205-193

Fig. 6 *Bushing Correctly Installed In Caliper*

caliper assembly. Flanges should be seated evenly on both sides of the bushing hole in the caliper assembly (Fig. 6).

Install the Guide Pin Sleeve into the guide bushing using the following procedure.

(1) Install the sleeve into one end of the bushing until the seal area of the bushing is past the seal groove in the sleeve (Fig. 7).

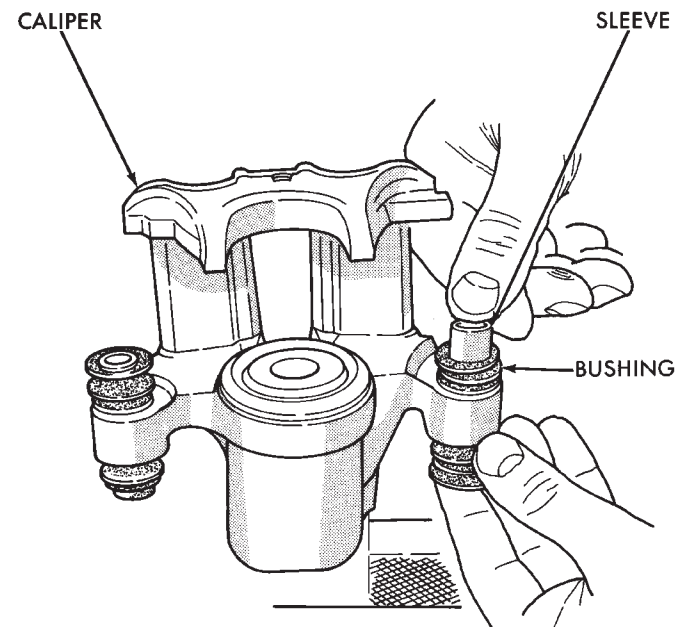

9105-60

Fig. 7 *Installing Caliper Sleeves*

(2) Holding the convoluted end of the bushing with one hand. Push the sleeve through the bushing (Fig.



7) until the one end of the bushing is fully seated into the seal groove on the one end of the sleeve.

(3) Holding the sleeve in place work the other end of the bushing over the end of the sleeve and into the seal groove (Fig. 8). Be sure the other end of the bushing did not come out of the seal groove in the sleeve.

(4) When the sleeve is seated properly into the bushing. The sealed for life bushing can be held between your fingers and easily slid back and forth without the bushing seal unseating from the sleeve.

Before installing caliper assembly on vehicle, inspect braking disc. If any conditions as described in Checking Braking Disc for Runout and Thickness are present the braking disc, must be replaced or refaced. If the braking disc does not require any servicing, install caliper assembly.

Install brake hose onto caliper using banjo bolt. Torque the brake hose to caliper assembly banjo bolt to 33 N•m (24 ft. lbs.). **New seal washers MUST always be used when installing brake hose to caliper.**

Bleed the brake system (see Bleeding Brake System).

BRAKE DISC (ROTOR)

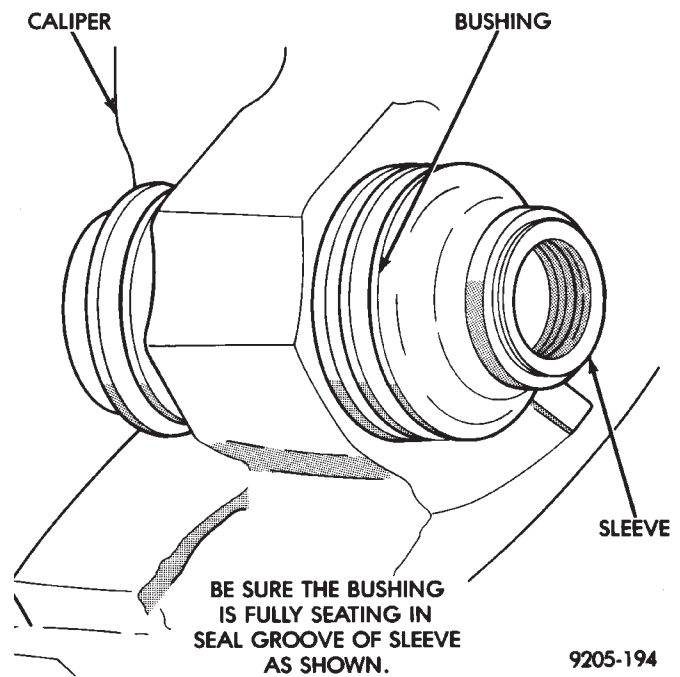

Fig. 8 Installed Caliper Bushing Sleeve

INDEX

	page		page
Braking Disc Removal	44	Installing Braking Disc	44
General Information	42	Refinishing Braking Disc	44
Inspection Diagnosis	42	Service Procedures	43

GENERAL INFORMATION

Any servicing of the braking disc requires extreme care to maintain the braking disc within service tolerances to ensure proper brake action.

CAUTION: If the braking disk (rotor) needs to be replaced with a new part. The protective coating on the braking surfaces of the rotor **MUST BE REMOVED** with an appropriate solvent, to avoid contamination of the brake shoe linings.

When replacing a rotor with a new part do **NOT** reface the new rotor. Rotor already has the required micro finish when manufactured, only remove the protective coating.

INSPECTION DIAGNOSIS

Before refinishing or refacing a braking disc, the disc should be checked and inspected for the following conditions:

- Braking surface scoring, rust, impregnation of lining material and worn ridges.
- Excessive lateral rotor runout or wobble.
- Thickness variation (Parallelism).

Dishing or distortion (Flatness).

If a vehicle has not been driven for a period of time. The discs will rust in the area not covered by the brake lining and cause noise and chatter when the brakes are applied.

Excessive wear and scoring of the disc can cause temporary improper lining contact if ridges are not removed before installation of new brake shoe assemblies.

Some discoloration or wear of the disc surface is normal and does not require resurfacing when linings are replaced.

Excessive runout or wobble in a disc can increase pedal travel due to piston knock back. This will increase guide pin bushing wear due to tendency of caliper to follow disc wobble.

Thickness variation in a disc can also result in pedal pulsation, chatter and surge due to variation in brake output. This can also be caused by excessive runout in braking disc or hub.

Dishing or distortion can be caused by extreme heat and abuse of the brakes.

SERVICE PROCEDURES

CHECKING BRAKING DISC FOR RUNOUT AND THICKNESS

On vehicle, braking disc (rotor) runout is the combination of the individual runout of the hub face and the runout of the disc. (The hub and disc are separable). To measure runout on the vehicle, remove the wheel and reinstall the lug nuts tightening the disc to the hub. Mount Dial Indicator, Special Tool C-3339 with Mounting Adaptor, Special Tool SP-1910 on steering arm. Dial indicator plunger should contact disc (braking surface) approximately one inch from edge of disc (See Fig. 1). Check lateral runout (both sides of disc) runout should not exceed 0.13 mm (0.005 inch).

If runout is in excess of the specification, check the

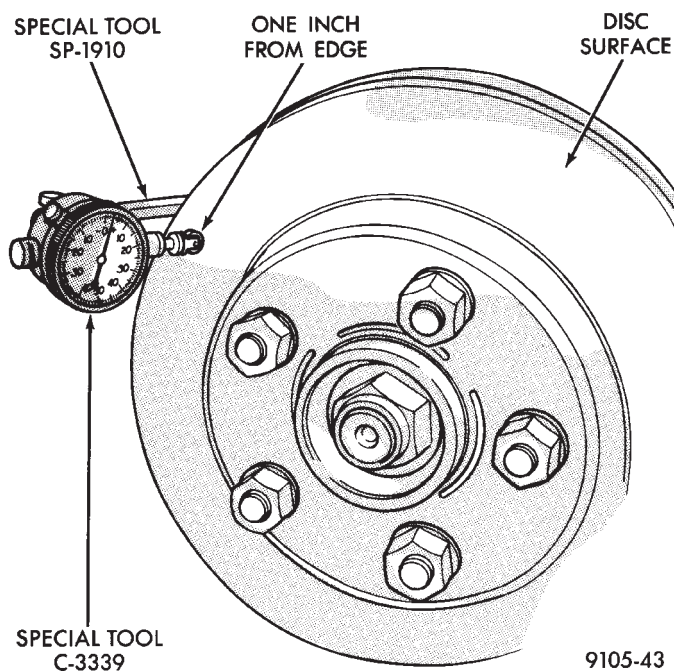

Fig. 1 Checking Braking Disc for Runout

lateral runout of the hub face. Before removing disc from hub, make a chalk mark across both the disc and one wheel stud on the high side of runout. So you'll know exactly how the disc and hub was originally mounted (Fig. 2). Remove disc from hub.

Install Dial Indicator, Special Tool C-3339 and Mounting Adaptor, Special Tool SP-1910 on steering knuckle. Position stem so it contacts hub face near outer diameter. Care must be taken to position stem outside the stud circle but inside the chamfer on the hub rim. **Clean hub surface before checking.** (See Fig. 3)

Runout should not exceed 0.08 mm (0.003 inch). If runout exceeds this specification, hub must be replaced. See Suspension Group 2. If hub runout does not exceed this specification, install disc on hub with chalk marks two wheel studs apart (Fig. 4). Tighten nuts in

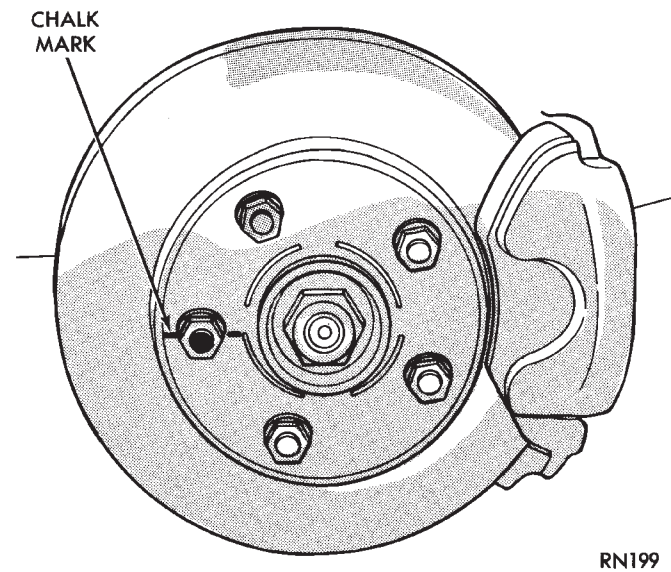

Fig. 2 Marking Braking Disc and Wheel Stud

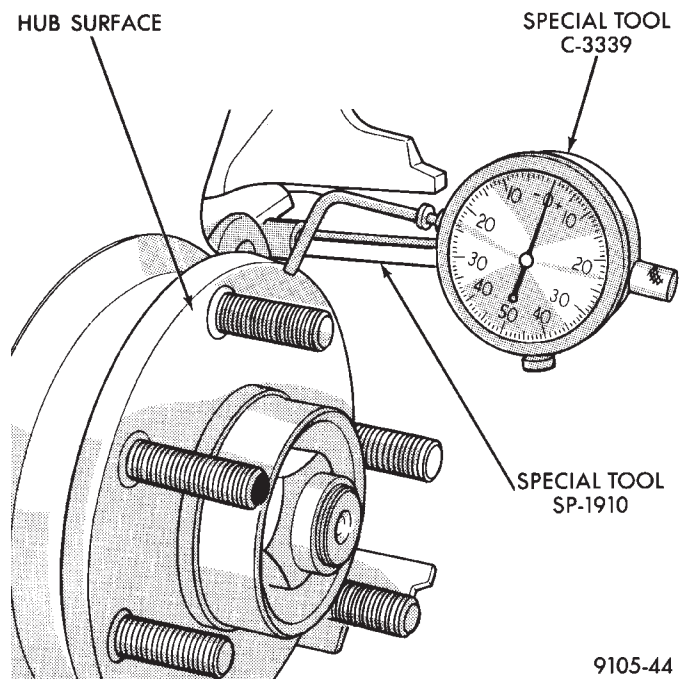

Fig. 3 Checking Hub for Runout

the proper sequence and torque to specifications. Finally, check runout of disc to see if runout is now within specifications.

If runout is not within specifications. Install a new braking disc or reface disc, being careful to remove as little as possible from each side of disc. Remove equal amounts from each side of disc. Do not reduce thickness below minimum thickness cast into the unmachined surface of the rotor.

Thickness variation measurements of disc should be made in conjunction with runout. Measure thickness of disc at 12 equal points with a micrometer at a radius approximately 25.4 mm (1 inch) from edge

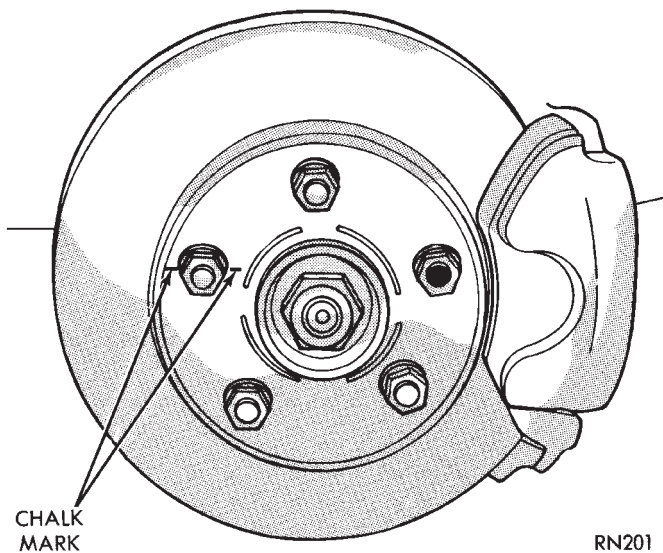

Fig. 4 Index Braking Disc and Wheel Stud

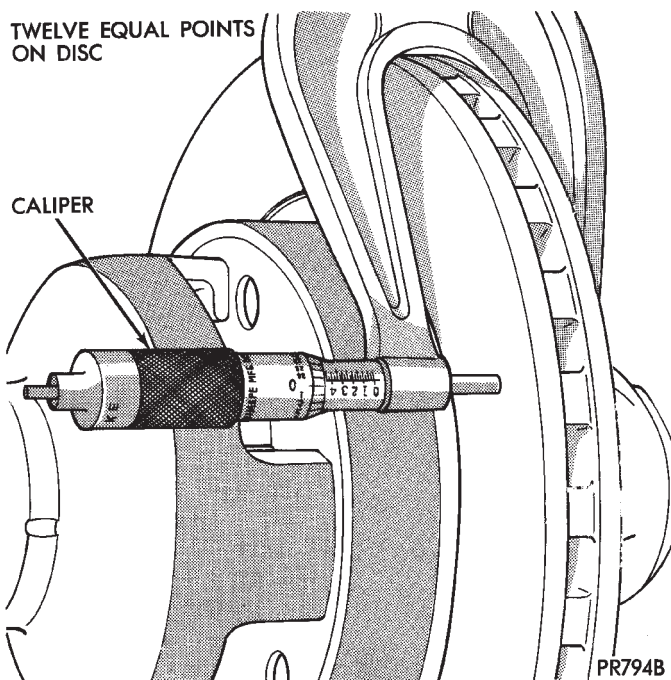

Fig. 5 Checking Disc for Thickness

of disc (Fig. 5). If thickness measurements vary by more than 0.013 mm (0.0005 inch) disc should be removed and resurfaced (Figs. 6 and 7), or a new disc installed. If cracks or burned spots are evident in the disc, disc must be replaced.

Light scoring and/or wear is acceptable. If heavy scoring or warping is evident, the disc must be refinished or replaced (See Refinishing/Refacing Braking Disc). If cracks are evident in the disc, replace the disc.

BRAKING DISC REMOVAL

(1) Raise vehicle on hoist or jackstands. Remove wheel and tire assembly.

(2) Remove caliper assembly, as described under Brake Shoe Removal in this Group, (but do not discon-

nect brake line). Suspend caliper from wire hook or loop to avoid strain on flexible hose.

(3) Remove braking disc from the hub.

INSTALLING BRAKING DISC

(1) Slide braking disc on hub. Clean both sides of braking disc with alcohol or suitable solvent.

(2) Install caliper assembly, as described in Brake Shoe Installation paragraph.

REFINISHING BRAKING DISC

REFACING BRAKING DISC

Refacing of the braking disc is not required each time the shoe assemblies are replaced.

If the braking disc surface is deeply scored or warped or there is a complaint of brake roughness or pulsation the rotor should be resurfaced or refaced (Figs. 6 and 7).

When refacing a braking disc the required 0.10 mm (0.004 inch) TIR (Total Indicator Reading) and 0.013 mm (0.0005 inch) thickness variation limits **MUST BE MAINTAINED**. **Extreme care** in the operation of braking disc turning equipment is required.

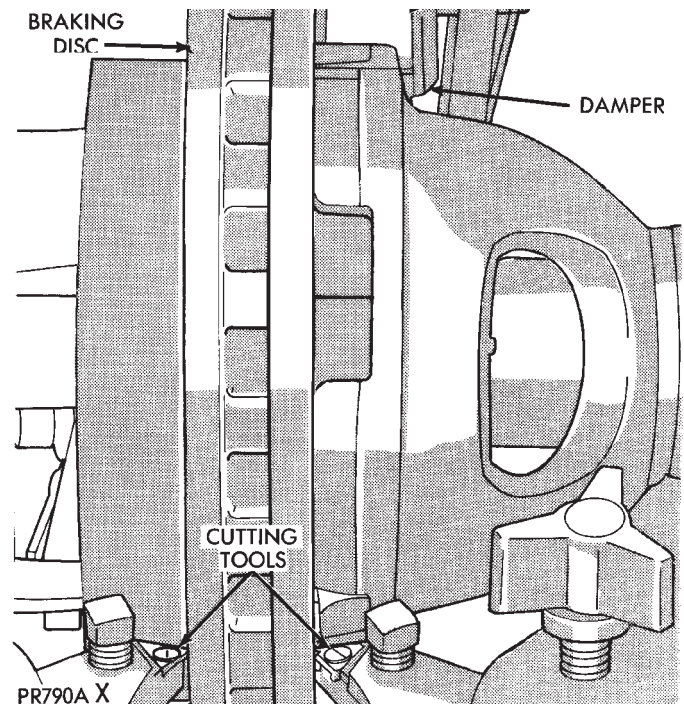

Fig. 6 Refacing Braking Disc

The collets, shafts and adapters in the lathe and the bearing cups in the rotor **MUST** be clean and free from any chips or contamination.

When mounting the disc on the lathe, strict attention to the lathe manufacturer's instructions is required.

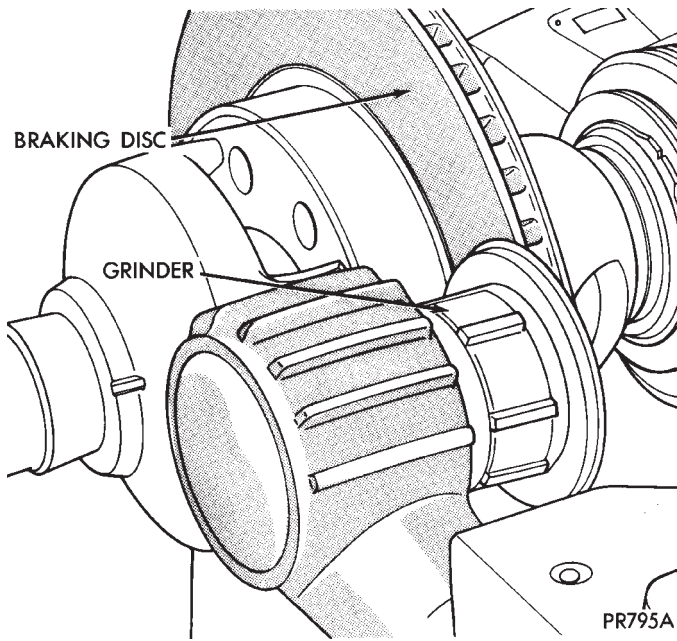

Fig. 7 Resurfacing Braking Disc (Final Finish)

If the disc is not mounted properly the run-out will be worse after refacing than before refacing.

The use of a double straddle cutter (Fig. 6) that machines both sides of the disc at the same time is highly recommended.

RESURFACING BRAKING DISC

This operation can be used when the disc surface is rusty or has lining deposits.

A sanding disc attachment will remove surface contamination without removing much braking disc material.

It will generally follow variations in thickness that are in the disc.

The following chart shows the location of measurements and specifications when servicing the braking disc.

All braking discs have markings for minimum allowable thickness cast on an un-machined surface (Fig. 8). This surface may be as shown in (Fig. 8) or on an alternate surface.

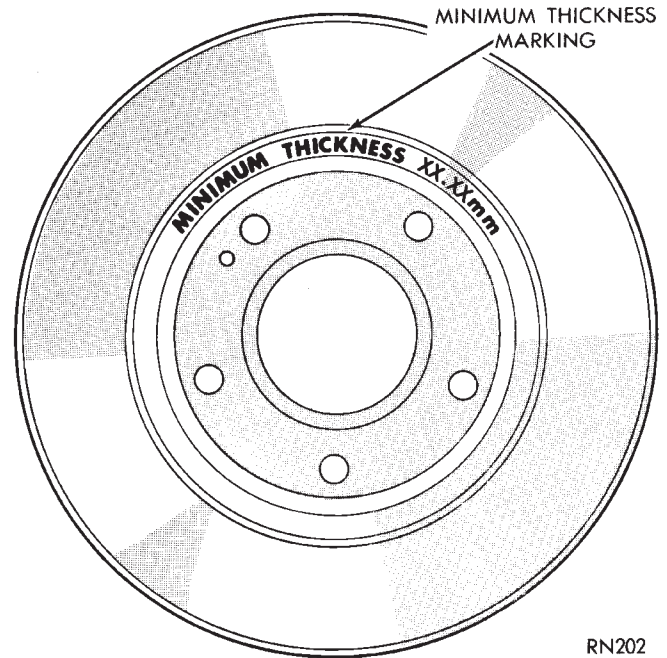

Fig. 8 Minimum Thickness Markings

This marking includes 0.76 mm (0.030 inch) allowable disc wear beyond the recommended 0.76 mm(0.030 inch) of disc refacing.

BRAKING DISC (ROTOR) REFINISHING LIMITS

	Thickness	Minimum Thickness	Thickness Variation	Disc Runout*	Micro Finish
Braking Disc	22.13-21.87 mm (.870-.861 in.)	20.4 mm (.803 in.)	.013 mm (.0005 in.)	.13 mm (.005 in.)	15-80 RMS

*TIR – Total Indicator Reading (measured on vehicle)

PARKING BRAKES

INDEX

	page		page
Front Parking Brake Cable	48	Rear Parking Brake Cable	49
General Information	1	Service Procedures	48
Parking Brake Pedal Assembly	48		

GENERAL INFORMATION

The rear wheel service brakes also act as parking brakes. The brake shoes are mechanically operated by an internal lever and strut connected to a flexible steel cable. The different length rear cables are connected to the front cable by an equalizer/adjuster assembly that is enclosed in a covered anchor bracket. The front cable extends to the parking brake pedal assembly (Figs. 1 and 4).

The parking brake cables are constructed of special materials and use unique construction with internal seals. This helps to provide good corrosion protection in severe environments and resistance to freezing in cold wet climates. Ease of and more accurate parking brake adjustment is provided by using the bent nail adjuster.

Cable routing and brake shoe actuation (for the parking brake) is as follows. The right rear cable enters the support from the rear. The internal lever is attached to the primary (front) shoe where it pivots to push the strut into the secondary (rear) shoe. The left brake is traditional, the cable enters the support from the front. The lever is attached to the secondary (rear) shoe to push the strut into the primary (front) shoe.

The left and right brake shoes look similar, **BUT THEY ARE NOT INTERCHANGEABLE.** The backing plates and cables are color coded; left is black, right is grey.

9205-195

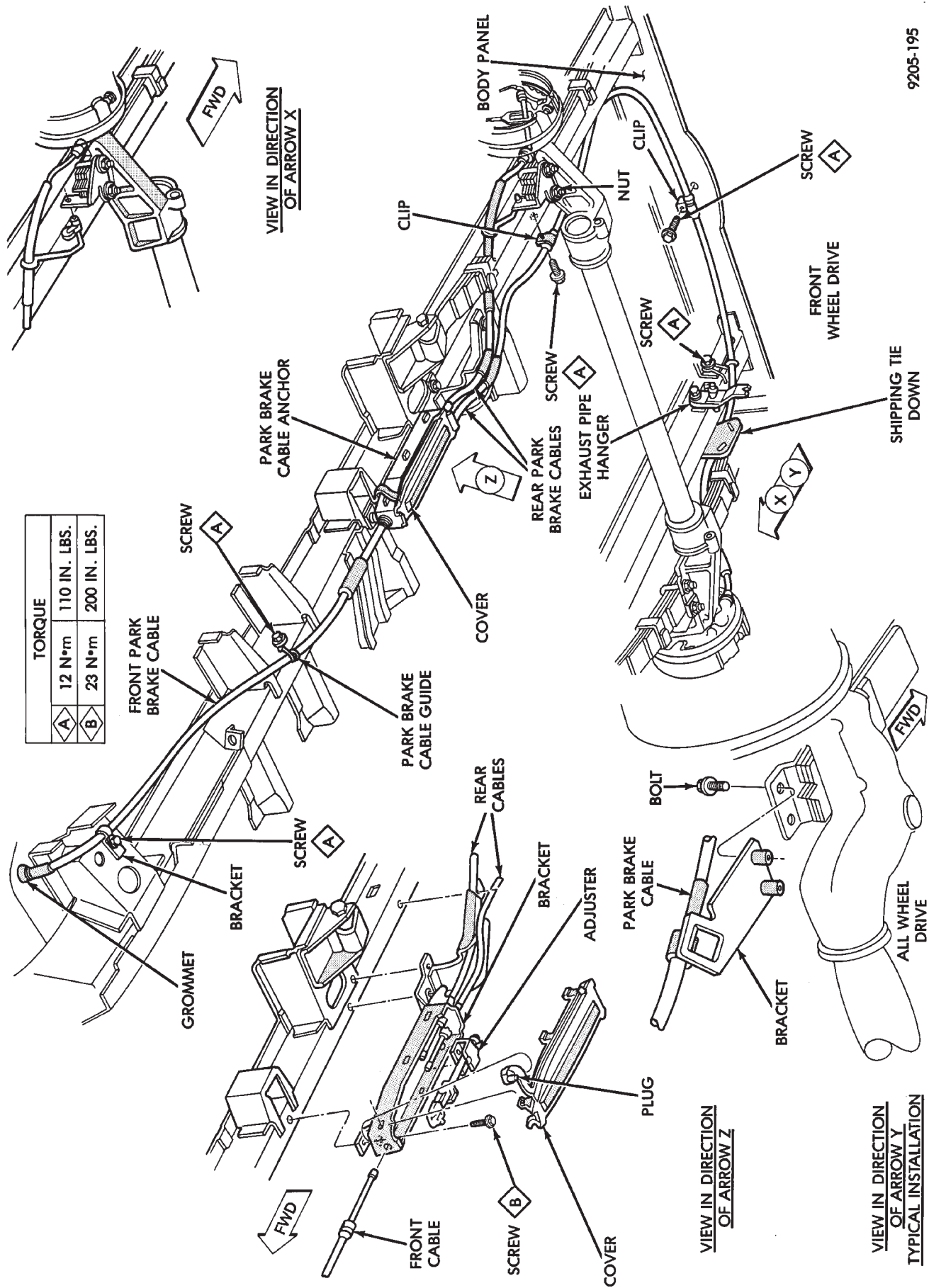

Fig. 1 Parking Brake Cable Routing F.W.D. & A.W.D.

SERVICE PROCEDURES

ADJUSTING PARKING BRAKE

The service brakes must be properly adjusted before adjusting the parking brake.

Remove plastic cover by pressing in the fingers of the cover through holes in bracket (Fig. 1).

Before loosening cable adjusting nut, clean threads with brush and lubricate with grease. Do not use a metal wire brush because it will scratch off plating and coating.

Release the parking brake pedal then back off cable adjusting nut so there is slack in the cable.

Push parking brake pedal all the way to the floor.

Mark bent nail adjuster approximately 6 mm (1/4 inch) from bracket (Fig. 2).

Tighten adjusting nut until mark moves into alignment with edge of bracket. **Important:** Replace bent nail with a new part if nail end hook has moved all the way to the bracket.

Replace plastic cover and tethered plug.

Apply and release the parking brake to see that the rear wheels rotate freely without dragging.

CAUTION: The threaded rod, washer and nut of the adjuster are made of stainless steel. Do not use a non-stainless steel washer or nut because an electrochemical reaction could occur. This could cause highly accelerated corrosion leading to failure of the washer or nut.

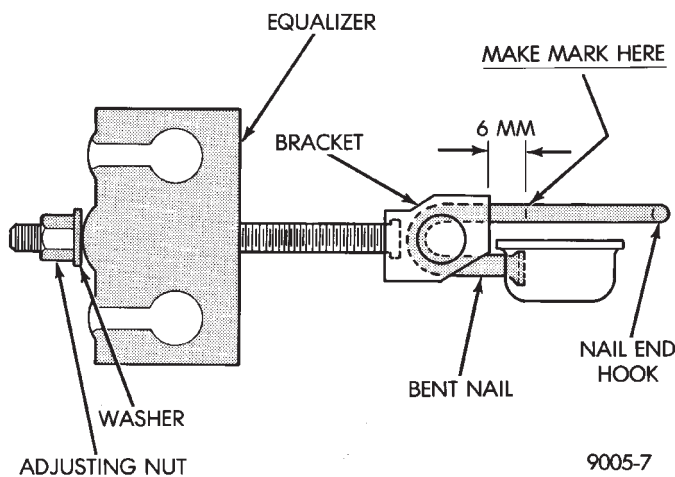

Fig. 2 Equalizer/Bent Nail Adjuster Assembly

PARKING BRAKE PEDAL ASSEMBLY

REMOVE

Loosen cable adjusting nut and disconnect front cable from adjuster (Fig. 2).

Remove sill molding/cowl side scuff panel and steering column cover. Increase access by removing fuse box, if required.

Disconnect the electrical connector for the brake light switch. Remove pedal assembly to body attaching bolts (Fig. 3).

Remove front cable strand button from clevis. Tap cable housing end fitting out of assembly (Fig. 3).

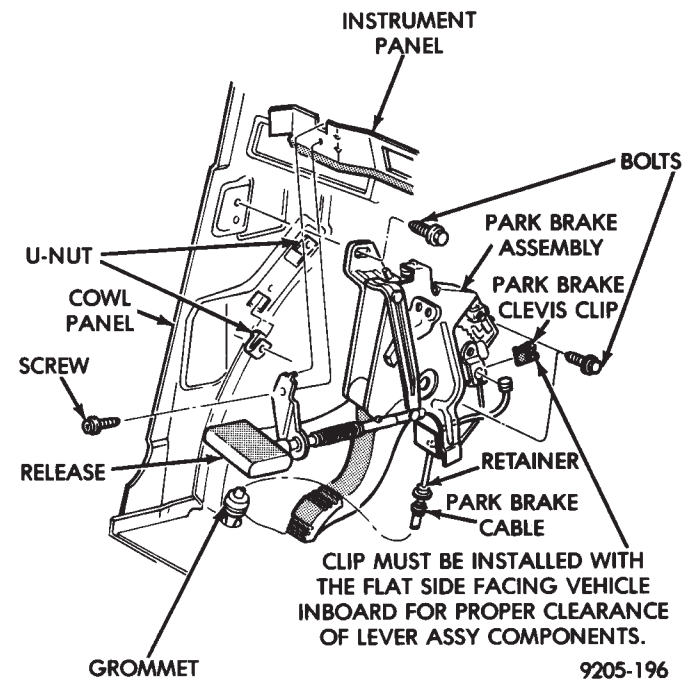

Fig. 3 Parking Brake Pedal Remove And Install

INSTALL

Install cable retainer into pedal assembly bracket (Fig. 3).

Install cable into retainer and strand button into clevis (Fig. 3).

Bolt pedal assembly into place. Tighten pedal assembly attaching bolts to 28 N•m (250 in. lbs.). Install electrical connector for the brake light switch.

Install fuse box, steering column cover and sill molding/cowl side scuff panel.

Connect front cable and adjust parking brake (Fig. 2). See Adjusting Parking Brake in this section of the service manual for the correct adjusting procedure.

FRONT PARKING BRAKE CABLE

REMOVE

Loosen cable adjusting nut and disengage front cable from adjuster. Remove cable housing retainer from anchor bracket, by sliding a 14 mm box wrench over cable retainer and compressing the three fingers. Alternate method is to use an aircraft type hose clamp and screwdriver. This is similar to the method shown for removing the parking brake cable from the support plate (Fig. 4).

Remove cable guide brackets from frame rail and loosen cable housing at pedal assembly.

Lift floor mat for access to floor pan and force seal out of hole (into vehicle).

Pull cable end forward and disconnect button from clevis. Tap cable housing end fitting out of pedal assembly bracket.

Pull cable assembly through hole.

INSTALL

Pass cable assembly through hole in floor from inside vehicle (Fig. 3).

Install cable retainer into brake pedal assembly bracket and then install cable housing end fitting into retainer.

Engage cable strand button into clevis.

Install floor pan seal and floor mat.

Insert brake cable and housing into anchor bracket making certain that housing retainer fingers lock the housing firmly into place.

Install cable guide brackets.

Assemble adjuster to front cable.

Adjust parking brake.

REAR PARKING BRAKE CABLE

REMOVE

With vehicle jacked up on suitable hoist remove wheel and tire.

Back off cable adjusting nut to provide slack and disconnect rear cable from equalizer bracket.

To remove cable from anchor bracket. Remove cable housing retainer from anchor bracket by sliding a 14 mm box wrench over retainer end compressing the three fingers. Alternate method is to use an aircraft type hose clamp and screwdriver. This is similar to the method shown for removing the brake cable from the brake support plate (Fig. 4).

Remove cable wrap-around clips where applicable.

Disconnect cable guide wires where applicable.

Remove brake drum and hub from spindle.

Disconnect cable from brake internal lever.

Remove park brake cable housing retainer from the brake support plate. Use the same method for removing cable retainer from brake support plate as was

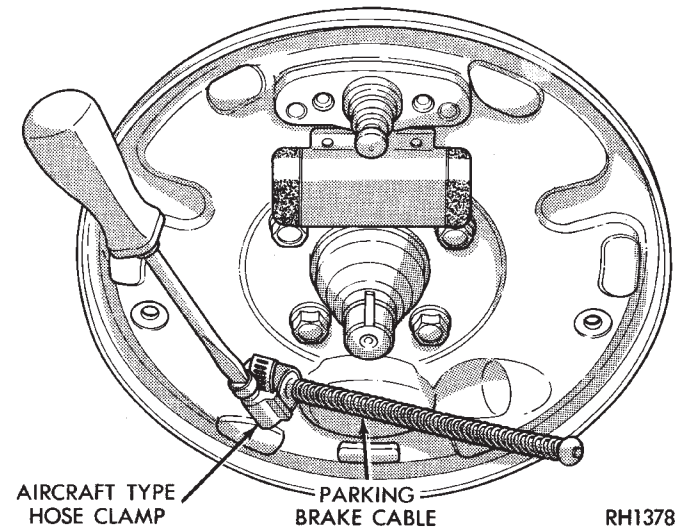

Fig. 4 Removing Brake Cable from Brake Support Plate

used above for the cable anchor bracket.

INSTALL

Insert park brake cable into hole in the brake support plate. Attach park brake cable to park brake internal lever attached to brake shoe.

Insert cable housing retainer into brake support plate making certain that cable housing retainer fingers lock the housing and retainer firmly into place.

Install brake drum, wheel and tire.

Insert cable housing retainer into anchor bracket making certain that cable housing retainer fingers lock the housing firmly into place.

Attach cable guide wires and wrap-around clips where applicable.

Connect equalizer bracket.

Adjust service brakes and then adjust parking brake.

MASTER CYLINDER

INDEX

	page	page	
General Information	49	Service Procedures	50
Reservoir Replacement	50		

GENERAL INFORMATION

The tandem master cylinder (Fig. 1) has a glass reinforced nylon reservoir and an anodized aluminum body.

CAUTION: Do not hone the bore of the cylinder, as this will remove the anodized surface.

The master cylinder reservoir is indexed to prevent installation in the wrong direction. The cap diaphragms are slit to allow pressure to equalize.

The secondary outlet tube from the master cylinder is connected to the proportioning valve mounted under the master cylinder. The front part of this valve supplies the right rear and left front brakes.



The primary outlet tube from the master cylinder is also connected to the proportioning valve. The back part of this valve supplies the right front and left rear brakes.

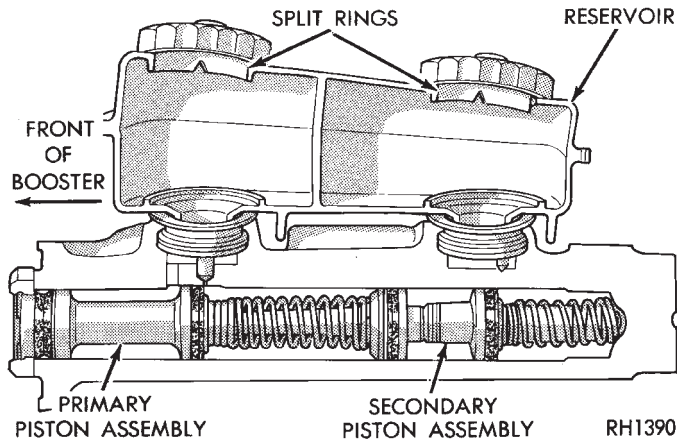

Fig. 1 Aluminum Master Cylinder

RESERVOIR REPLACEMENT

See Master Cylinder Removal.
 Clean master cylinder housing and fluid reservoir.
 Remove caps and empty brake fluid from reservoir.
 Position master cylinder in vise.
 Rock fluid reservoir from side to side and remove from master cylinder housing (Fig. 2).

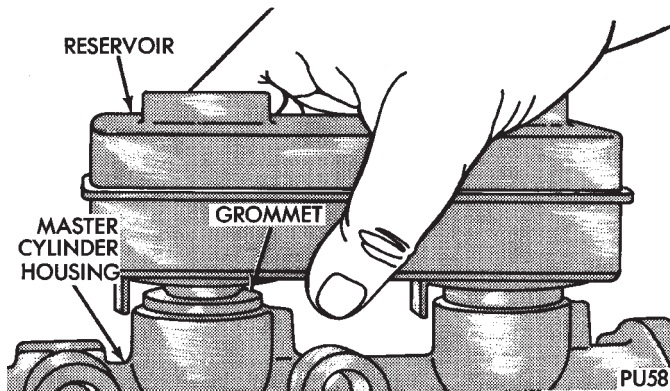

Fig. 2 Removing Reservoir Do not pry fluid reservoir off master cylinder housing using a tool, damage to the fluid reservoir may result.

Remove master cylinder housing-to-fluid reservoir grommets (Fig. 3).

Install new master cylinder housing-to-fluid reservoir grommets in master cylinder housing.

Lubricate fluid reservoir mounting areas with brake fluid. Place reservoir in position over grommets. Seat fluid reservoir onto master cylinder housing, by applying downward pressure while using a side to side rocking motion until reservoir is fully seated in grommets.

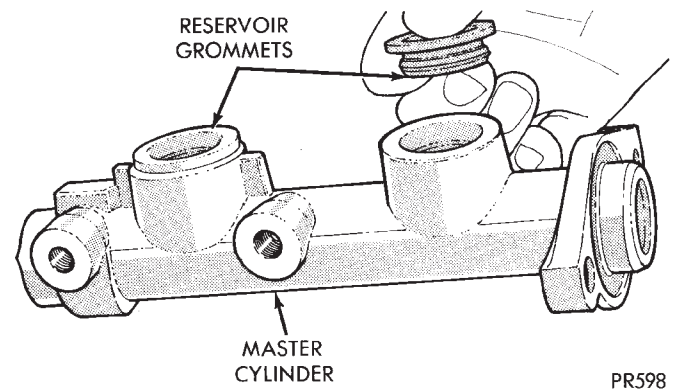

Fig. 3 Removing Grommets

Be sure reservoir is positioned properly. All lettering should be properly read from the left side of the master cylinder.

Make sure bottom of reservoir touches top of grommet.

SERVICE PROCEDURES

MASTER CYLINDER

REMOVE

Disconnect primary and secondary brake tubes from master cylinder housing. Install plugs at brake tube outlets.

Remove 2 nuts (Fig. 4) attaching master cylinder housing to power brake booster unit.

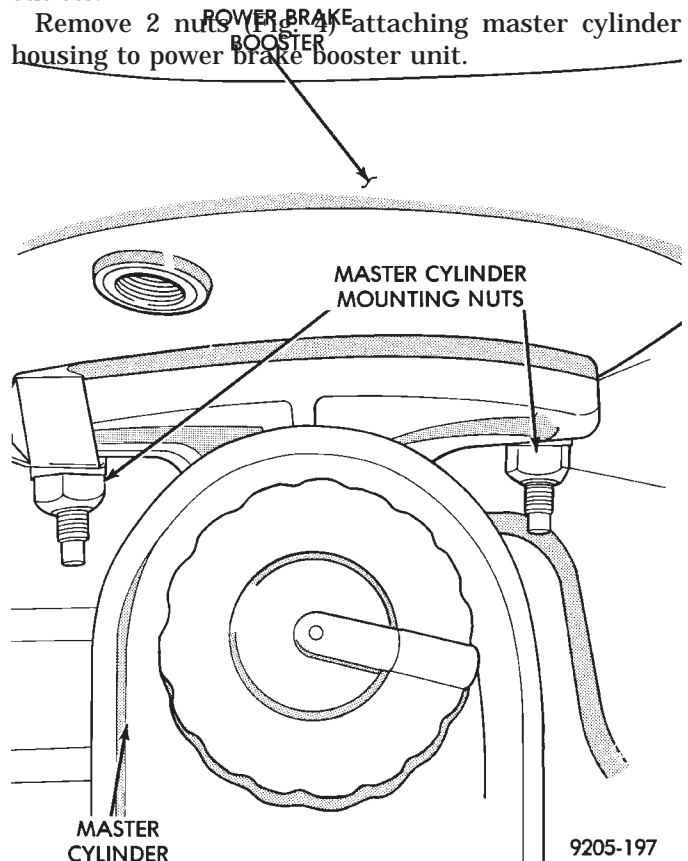

Fig. 4 Master Cylinder Mounting

Slide master cylinder straight out, and away from power brake booster unit.

BLEEDING MASTER CYLINDER

Clamp master cylinder in vise and attach Bleeding Tubes, Special Tool C-4546 (Fig. 5).

Use a residual valve on outlet of each bleeder tube, to keep air from being drawn back up tube and into master cylinder.

Fill both reservoirs to the appropriate full mark, with approved brake fluid.

Depress push rod slowly and then allow pistons to return. Repeat several times until all air bubbles are expelled (Fig. 5).

Remove bleeding tubes from master cylinder. Plug outlet ports on master cylinder and install caps on fluid reservoir.

Remove master cylinder from vise and install master cylinder back on the power brake unit.

It is not necessary to bleed the entire hydraulic system after replacing the master cylinder. Providing that the master cylinder had been thoroughly bled of all air and filled with approved brake fluid before installing it on the vehicle.

INSTALL

Position master cylinder over studs on power brake unit, align push rod with master cylinder piston.

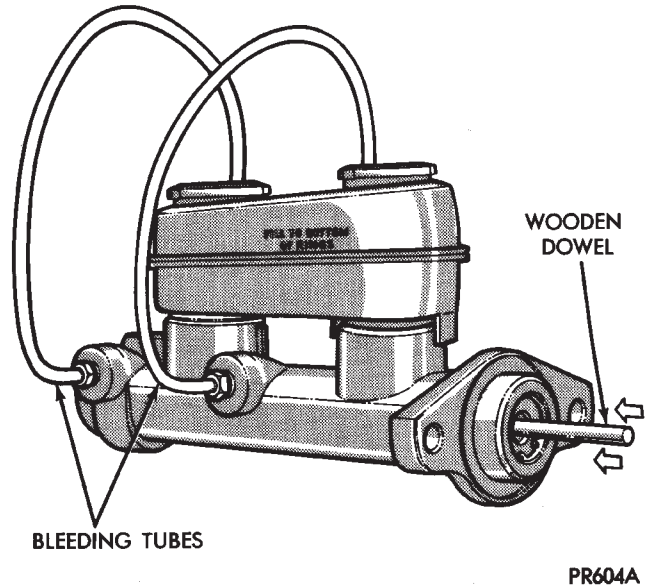

Fig. 5 Bleeding Master

Install master cylinder to power brake unit attaching nuts (Fig. 4) and tighten to 28 N•m (250 in. lbs.).

Connect brake tubes to master cylinder outlet ports. Tighten the brake tube to master cylinder fittings to 17 N•m (145 in. lbs.).

POWER BRAKES

INDEX

	page		page
General Information	51	Service Procedures	52

GENERAL INFORMATION

A 270 mm power brake booster assembly is used on these vehicles (Fig. 1 and 2).

The purpose of the power brake booster is to reduce the amount of force applied to the brake pedal, to obtain the required hydraulic pressure in the brake system to stop the vehicle.

The power brake booster can be identified if required, by the tag attached to the body of the booster assembly (Fig. 1). This tag contains the following information. The production part number of the power booster assembly, the date it was built and who manufactured it.

The power brake booster assembly is not a repairable part and must be replaced as a complete unit if it is found to be faulty in any way. The power booster vacuum check valve is not repairable but can be replaceable as an assembly.

The power brake booster is vacuum operated. The vacuum is supplied from the intake manifold through the power brake booster check valve (Fig. 1).

As the brake pedal is depressed, the power booster input rod moves forward. This opens and closes valves in the power booster, creating a vacuum on one side of a diaphragm and allowing atmospheric pressure to enter on the other. This difference in pressure forces the output rod of the power booster out against the primary piston of the master cylinder. As the pistons in the master cylinder move forward this creates the hydraulic pressure in the brake system.

Different systems and engine combinations require different vacuum hose routings. The hose is needed to supply the power brake unit with a vacuum signal from the engine's intake manifold. This vacuum signal is required for the proper operation of the power brake unit. Below is listed the different hose routing requirements and routing illustrations.

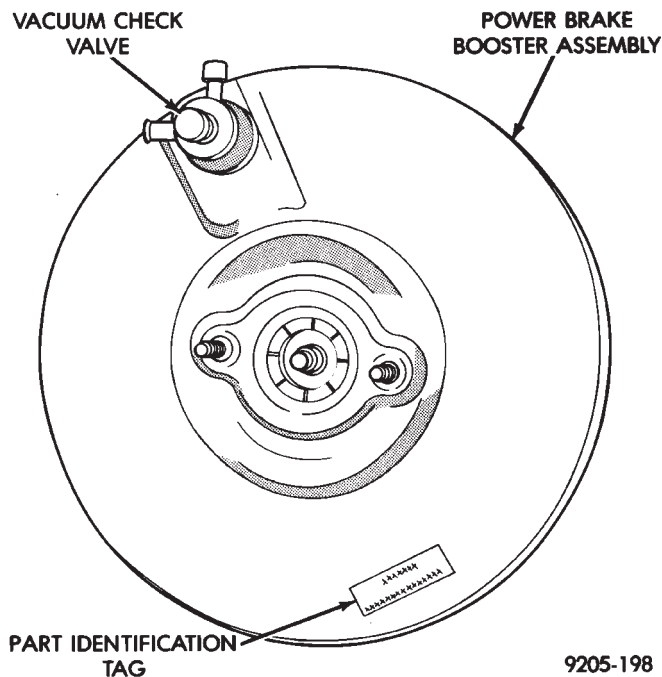

9205-198

Fig. 1 Power Brake Booster Identification

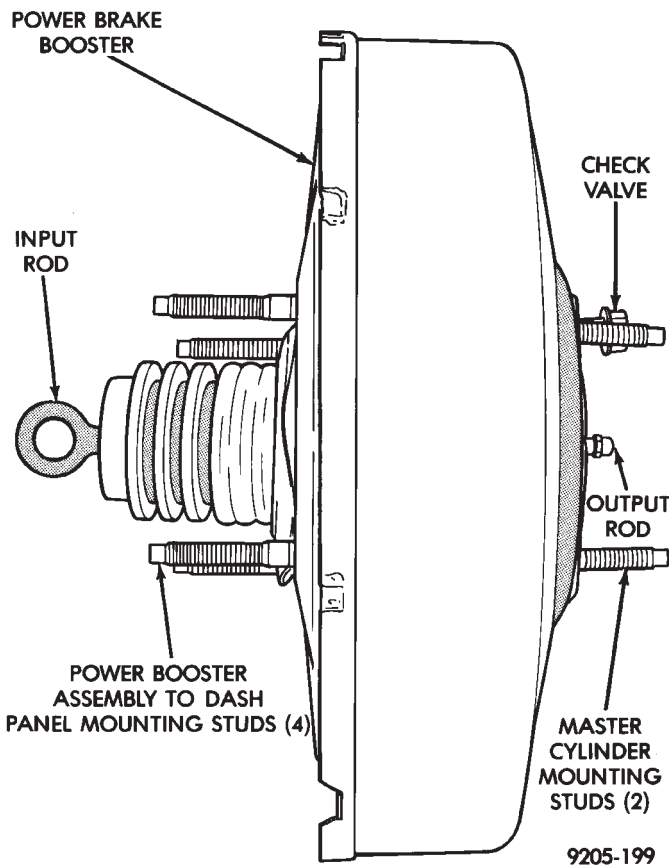

9205-199

Fig. 2 Power Brake Booster Assembly

Vehicles equipped with the Chrysler 2.5L engine use a charcoal filter in the hose between the booster and the throttle body (Fig. 3).

Vehicles equipped with the optional 3.0L and 3.3L

engine use a preformed vacuum hose connected directly to the intake manifold (Fig. 4 and 5).

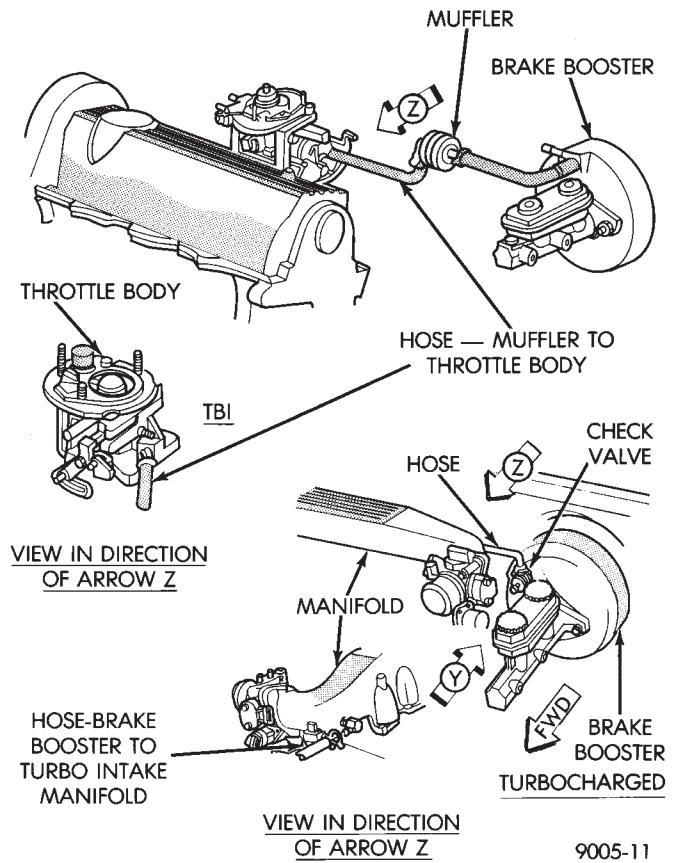

9005-11

Fig. 3 Power Brake Unit/Vacuum Hose Connections 2.5L TBI and 2.5L Turbocharged Engines

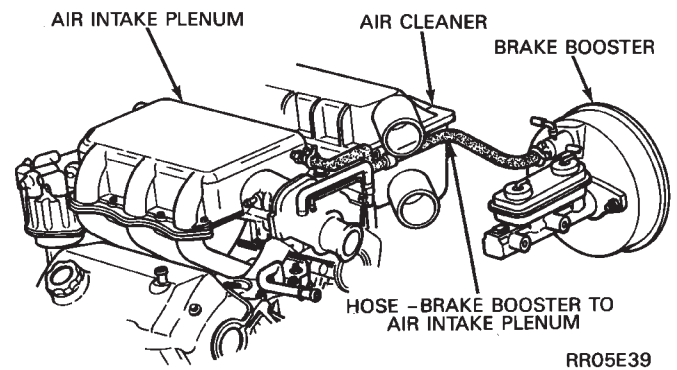

RR05E39

Fig. 4 Power Brake Unit/Vacuum Hose Connections 3.0L Engine

SERVICE PROCEDURES

POWER BRAKE BOOSTER ASSEMBLY

REMOVE

(1) Remove the 2 nuts (Fig. 6) attaching master cylinder assembly to power brake unit.

(2) Carefully slide master cylinder off mounting studs with brake lines attached, and allow the assembly to rest against fender shield.

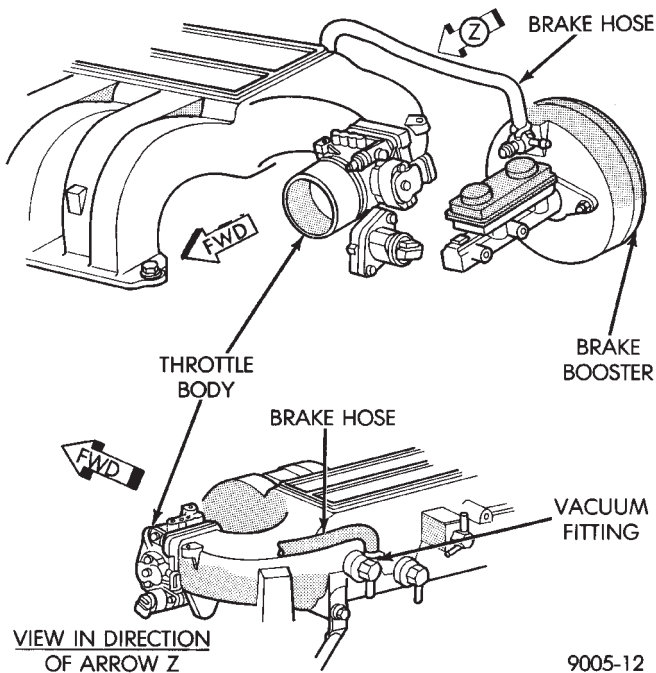

Fig. 5 3.3L Engine Power Brake Unit/Vacuum Hose Connections

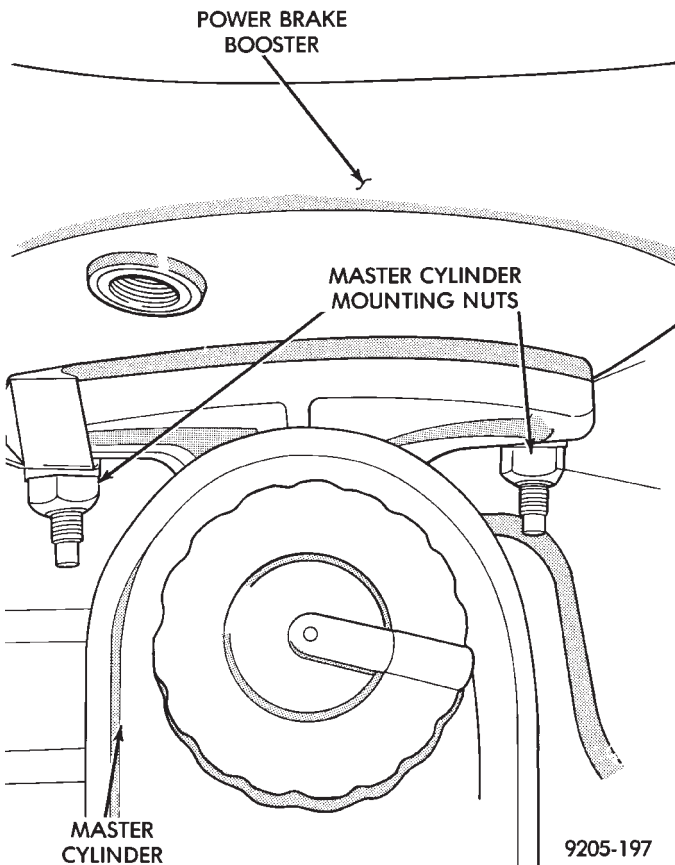

Fig. 6 Master Cylinder Mounting

(3) Disconnect vacuum hose from power brake booster check valve (Fig. 1). **DO NOT REMOVE CHECK VALVE FROM POWER BRAKE BOOSTER.**

(4) From under instrument panel, position a small screwdriver between the center tang on the power brake booster input rod to brake pedal pin retaining clip.

(5) Rotate screwdriver enough to allow retainer clip center tang to pass over end of brake pedal pin and pull retainer clip off pin. **Discard retainer clip it is not to be reused, replace only with a new retainer clip.**

(6) Remove the four nuts that attach the power brake booster to the vehicle dash panel. Nuts are accessible from under the dash panel in the area of the steering column and pedal bracket (Fig. 7).

(7) Unfasten brackets on steel heater water line at

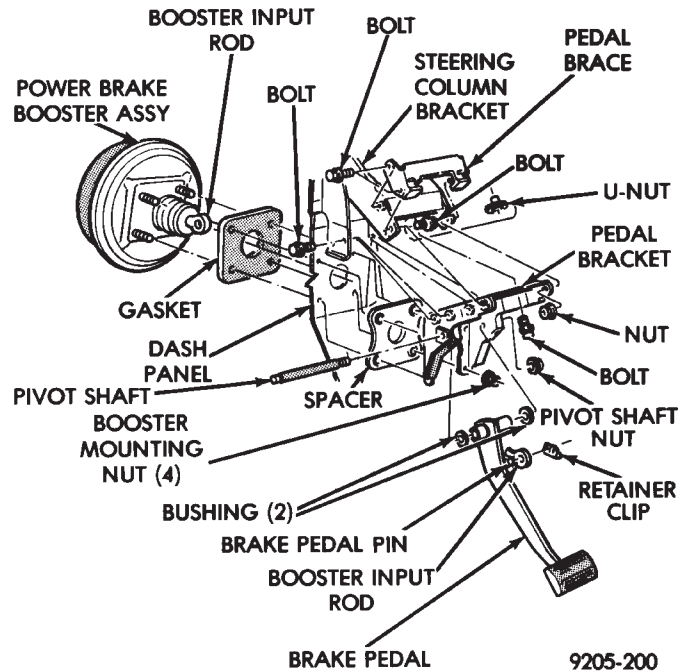

Fig. 7 Power Brake Booster Mounting

dash panel and left frame rail. **On Manual Transmission vehicles**, unfasten clutch cable bracket at shock tower and move aside.

(8) Slide the power brake unit up and to the left (mounting holes are slotted) on the dash panel, then tilt inboard and up to remove.

CAUTION: Do not attempt to disassemble power brake unit as this booster is serviced **ONLY** as a complete assembly.

INSTALL

(1) Position power brake booster onto dash panel.
 (2) Install and tighten the 4 power brake booster to dash panel mounting nuts (Fig. 7) to 29 N•m (250 in. lbs.) torque.

(3) Install steel heater water line and clutch cable bracket, if so equipped.

(4) Carefully position master cylinder on power brake unit.

(5) Install and tighten the 2 master cylinder to power booster mounting nuts (Fig. 6) to 29 N•m (250 in. lbs.) torque.

(6) Connect vacuum hose onto the check valve, located on the power brake unit.

(7) Using lubriplate, or equivalent, coat the bearing surface of pedal pin (Fig. 7).

(8) Connect power brake booster input rod to brake pedal pin and install a NEW retainer clip. **Use only a new retainer clip DO NOT USE the old clip.**

(9) Check stop light operation.

WHEEL BEARINGS

FRONT WHEEL BEARINGS

Front wheel drive vehicles are equipped with permanently sealed front wheel bearings. There is no periodic lubrication or maintenance recommended for these units. However if during servicing of the brake system, service to the front wheel bearing is required refer to Group 2, Suspension in this service manual.

REAR WHEEL BEARINGS (FRONT WHEEL DRIVE)

NORMAL SERVICE

The lubricant in the rear wheel bearings should be inspected whenever the hubs are removed to inspect or service the brake system, or every 30,000 miles (48 000 km). The bearing should be cleaned and repacked with a High Temperature Multipurpose E.P. Grease whenever the brake drums are resurfaced.

INSPECTION

Check lubricant to see that it is adequate in quantity and quality. If the grease is low in quantity, contains dirt, appears dry or milky in appearance, the bearings must be cleaned and repacked. **Do not add grease to a lubricated wheel bearing, it must be cleaned and completely repacked. Mixing of different types of greases in wheel bearings should be avoided since it may result in excessive thinning and leakage of the grease.**

REMOVAL AND INSTALLATION

For the servicing, removal and installation of the rear wheel bearings follow the procedure listed below.

(1) Remove the rear tire and wheel assembly.
 (2) Remove grease cap, cotter pin, nut lock, nut, thrust washer and outer wheel bearing.

(3) Carefully slide hub or drum from spindle. **Do not drag inner bearing or grease seal over stub axle (thread, bearing, and oil seal may be damaged.)** Using an appropriate tool remove the grease seal and inner bearing from the drum or hub. Discard grease seal, a new seal should be used when reinstalling the inner bearing. (See Fig. 1)

(5) Thoroughly clean all old grease from the outer and inner bearings, bearing cups and hub cavity (See Fig. 1). **To clean bearings, soak them in an appropriate cleaning solvent. Strike the flat surface of the bearing inner race against a hardwood block several times, to loosen grease. Immerse the bearings in solvent between blows to jar loose**

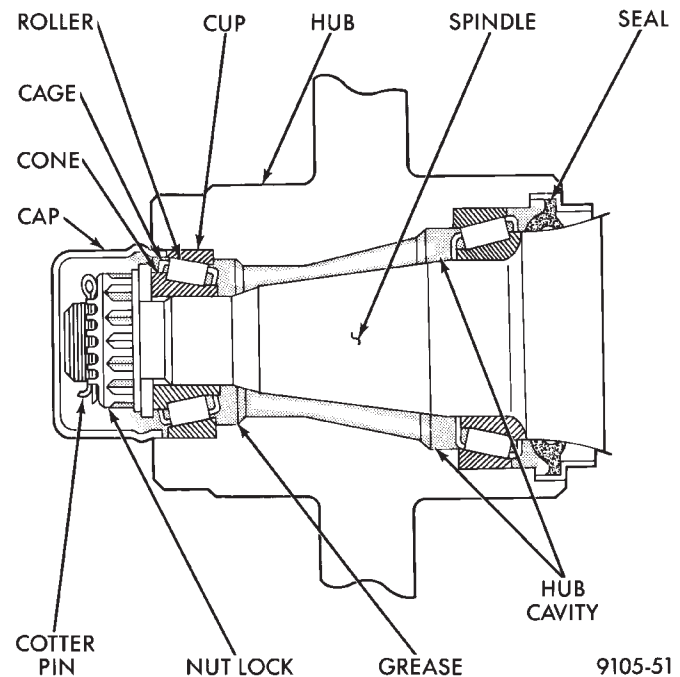

Fig. 1 Rear Wheel Bearings

and wash old particles of hardened grease from bearings. Repeat this operation until bearings are clean. Bearings can be dried using compressed air but do not spin the bearings. After cleaning, oil the bearings with engine oil. Insert the bearing into its appropriate cup, apply pressure to the bearing while rotating it to test them for pitting and roughness. Replace all worn or defective bearings. If bearing shows signs of pitting or roughness they should be replaced. Bearings must be replaced as a set, both the cup and the bearing need to be replaced at the same time. If bearings are suitable for further use, remove engine oil from bearings using appropriate solvent and dry bearings. Repack the bearings using a Multi-Purpose NLGI, Grade 2 EP Grease such as Mopar® or equivalent, and place them in a clean covered container until ready for installation. If a bearing packer is not available, hand pack grease into all cavities between bearing cage and rollers.

(6) If bearings and cups are to be replaced, remove cups from the drum or hub using a brass drift or suitable remover.



(7) Replace bearing cups with appropriate installing tool.

(8) Install inner bearing in grease coated hub and bearing cup, and install new grease seals using the appropriate seal installer.

(9) Coat outer hub cavity and cup with grease.

(10) Before installing hub or drum assembly, inspect stub axle and seal surface for burrs or roughness, and smooth out all rough surfaces.

(11) Coat the stub axle with Multi-Purpose NLGI, Grade 2 EP grease such as Mopar® or equivalent.

(12) Carefully slide the hub or drum assembly onto the stub axle. **Do not drag seal or inner bearing over the threaded area of the stub axle.**

(13) Install outer bearing, thrust washer and nut.

(14) Tighten the wheel bearing adjusting nut to 27 to 34 N•m (240 to 300 in. lbs.) while rotating hub or drum assembly. This seats the bearings.

(15) Back off adjusting nut 1/4 turn (90°) then tighten adjusting nut only finger tight.

(16) Position the nut lock over the bearing adjusting nut with one pair of slots in line with the cotter pin hole in the stub axle. Install cotter pin.

(17) Install the grease caps and the wheel and tire assemblies. Tighten wheel stud nuts to 115 N•m (85 ft. lbs.) on all models. Reinstall wheel covers if so equipped.

ANTI-LOCK BRAKE SYSTEM (BENDIX ANTI-LOCK 10 AS BODY FWD/AWD)

INDEX

	page		page
ABS Braking System Diagnosis	71	Anti-Lock Operation and Performance	58
ABS Controller Anti-Lock Brake (CAB) Service Precautions	72	Anti-Lock System Relays and Warning Lamps ...	67
ABS Equipped Vehicle Performance	58	Controller Anti-Lock Brake (CAB)	65
ABS Hydraulic Circuits and Valve Operation	69	General Information	56
ABS System Diagnostic Connector	65	General Service Precautions	75
ABS System Diagnostic Features	75	Major ABS Components	57
ABS System General Service Precautions	72	Mechanical Diagnostics and Service Procedures ..	73
ABS System Self-Diagnostics	59	On Car Electronic ABS Component Service	85
Anti-Lock Brake System Components	60	On Car Hydraulic ABS Component Service	75
Anti-Lock Brake System Definitions	56	Warning Systems Operation	59

GENERAL INFORMATION

The purpose of the Anti-Lock Brake System (ABS) (Fig. 1) is to prevent wheel lock-up under heavy braking conditions on almost any type of road surface. Anti-Lock Braking is desirable because a vehicle that is stopped without locking the wheels will retain directional stability and some steering capability. This allows the driver to retain greater control of the vehicle during heavy braking.

ANTI-LOCK BRAKE SYSTEM DEFINITIONS

In this section of the manual several abbreviations are used for the components that are in the Anti-Lock Braking System. They are listed below for your reference.

- CAB—Controller Anti-Lock Brake
- ABS—Anti-Lock Brake System
- PSI—Pounds per Square Inch (pressure)
- WSS—Wheel Speed Sensor

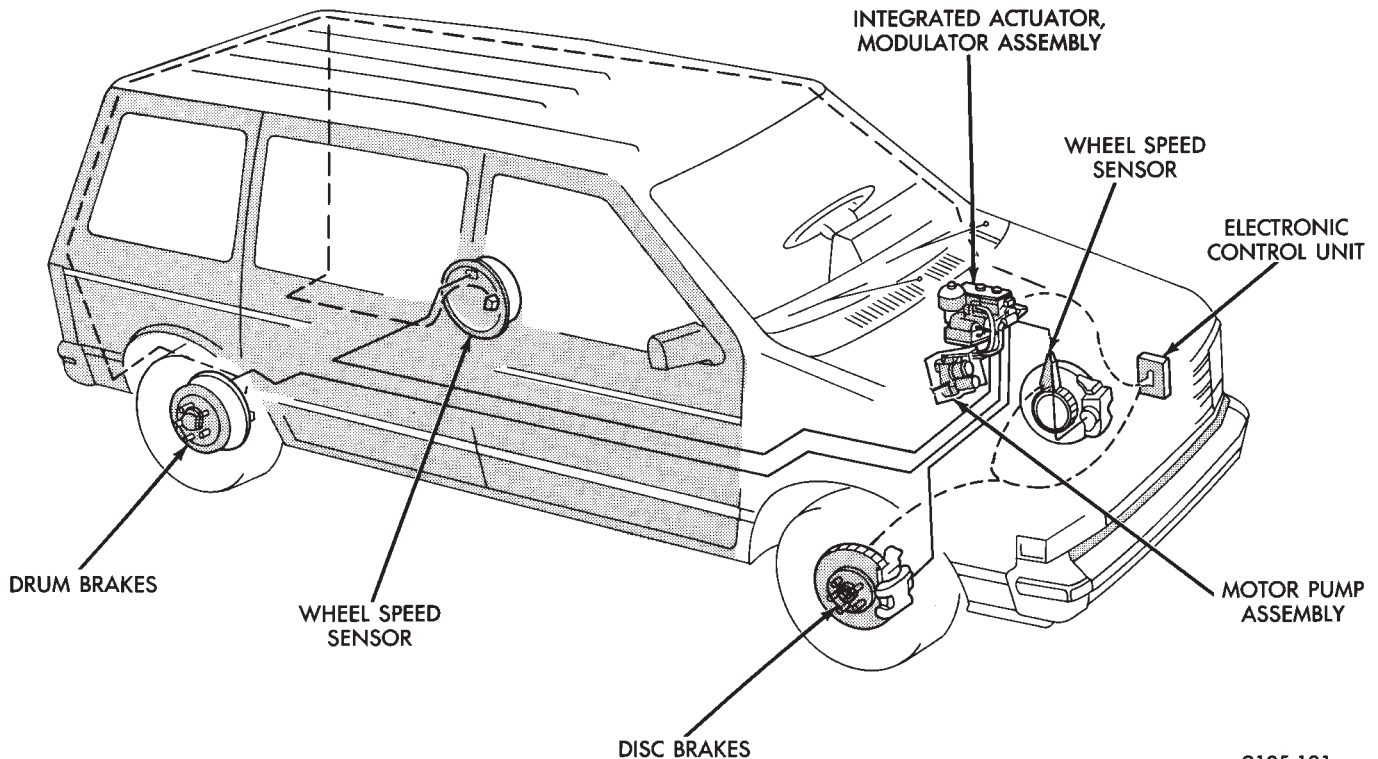
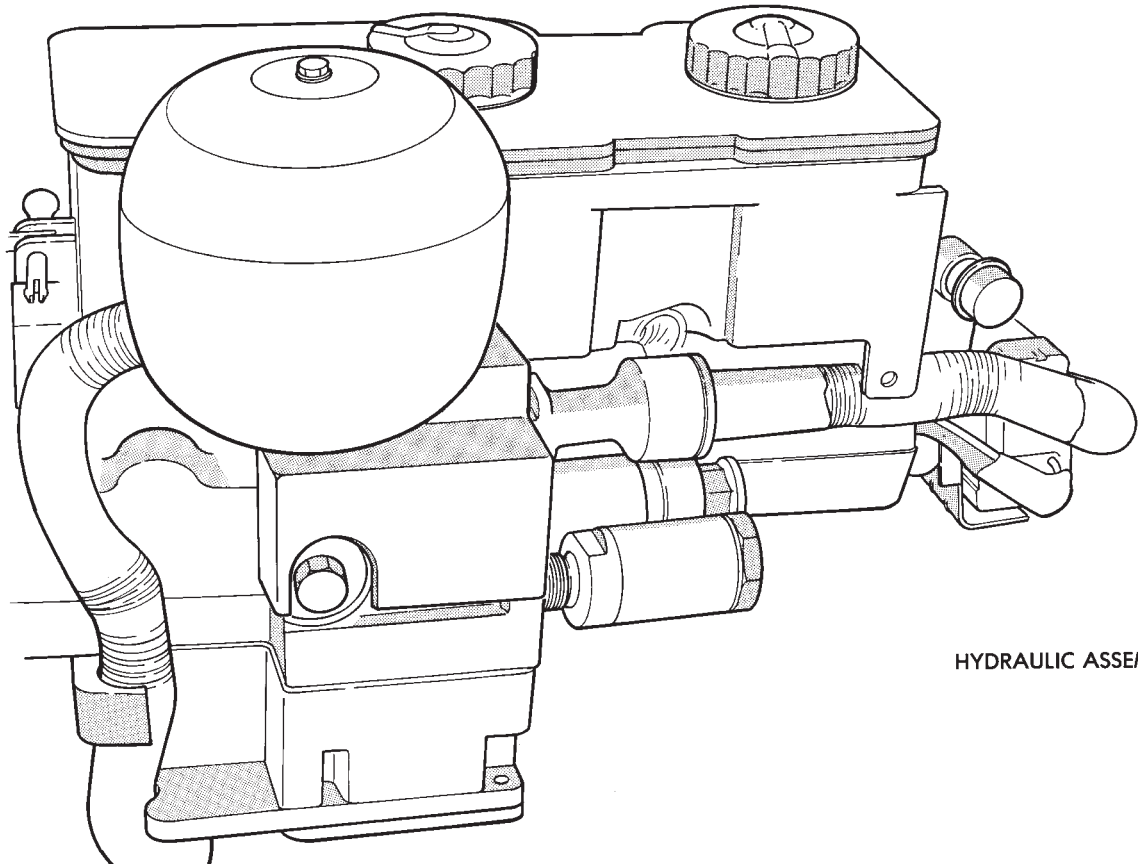

Fig. 1 Four-Wheel Anti-Lock Brake System



HYDRAULIC ASSEMBLY

9205-207

Fig. 1 ABS Hydraulic Assembly

MAJOR ABS COMPONENTS

The following is a list of major system components. Details of all components can be found later in this section.

HYDRAULIC ASSEMBLY

The Hydraulic Assembly (Fig. 1) provides the function of an integral master cylinder and hydraulic booster assembly, and contains the wheel circuit valves used for brake pressure modulation.

WHEEL SPEED SENSORS

A Wheel Speed Sensor (Fig. 2) is located at each wheel to transmit wheel speed information to the Controller Anti-Lock Brake (CAB).

CONTROLLER-ANTI-LOCK BRAKE (CAB)

The CAB (Fig. 3) is a small control computer that receives wheel speed information, controls Anti-Lock operation and monitors system operation.

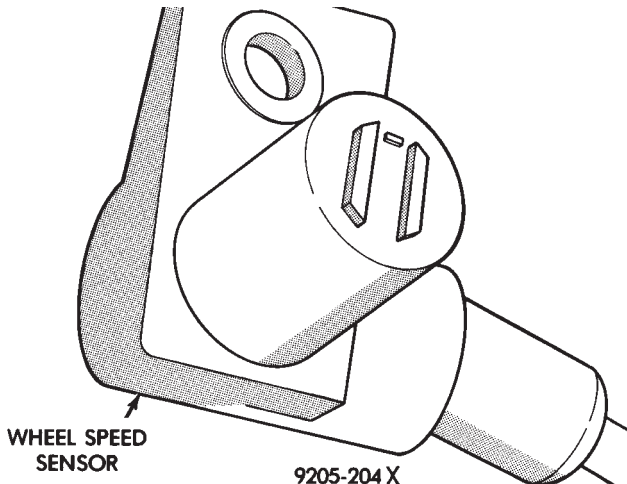

WHEEL SPEED SENSOR

9205-204 X

Fig. 2 Wheel Speed Sensor

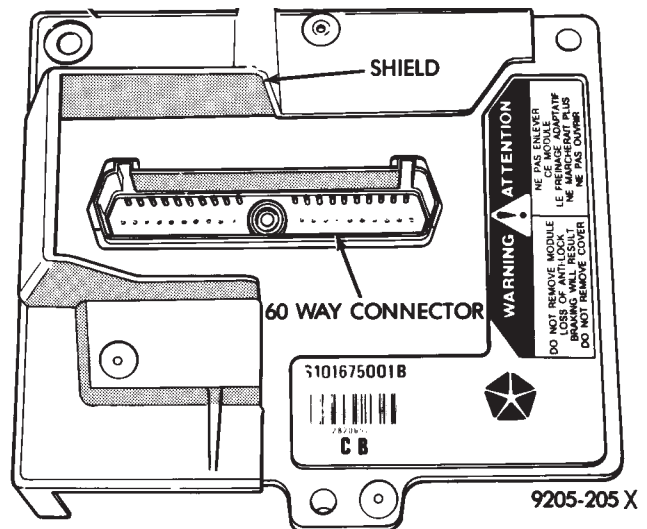

SHIELD

60 WAY CONNECTOR

WARNING ATTENTION

NE PAS ENLEVER LE PARE-CHOC. LE FREINAGE ADAPTIF NE MARCHE PAS. NE PAS ENLEVER LE PARE-CHOC. LE FREINAGE ADAPTIF NE MARCHE PAS.

DO NOT REMOVE SHIELD. BRAKING WILL RESULT. DO NOT REMOVE COVER.

9101675001B

C B

9205-205 X

Fig. 3 (CAB) Controller Anti-Lock Brake Module

PUMP/MOTOR ASSEMBLY

The Pump/Motor Assembly (Fig. 4) is an electrically driven pump. It takes low pressure brake fluid from the hydraulic assembly reservoir and pressurizes it for storage in the accumulators for power assist and Anti-Lock braking.

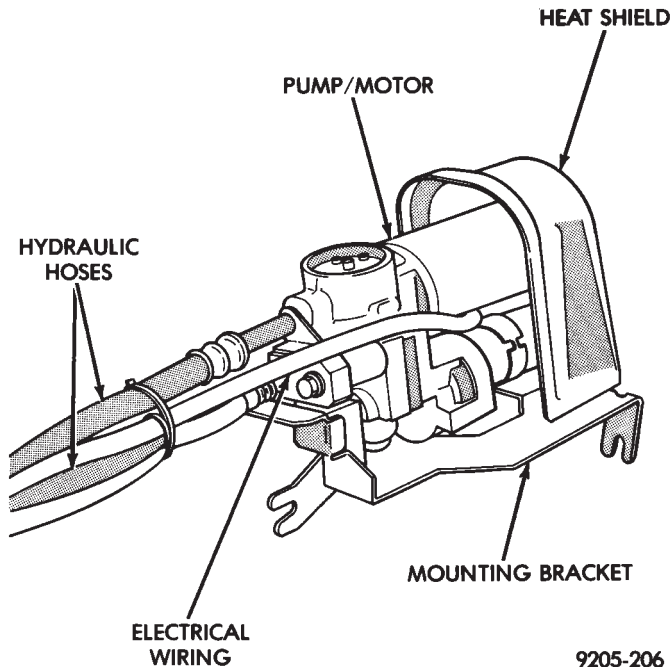

Fig. 4 ABS Pump/Motor Assembly

ANTI-LOCK OPERATION AND PERFORMANCE

NORMAL BRAKING SYSTEM FUNCTION

Under normal braking conditions, the ABS System functions much the same as a standard brake system with a diagonally split master cylinder. The primary difference is that power assist is provided by hydraulic power assist instead of the conventional vacuum assist.

If a wheel locking tendency is noticed during a brake application, the system will enter Anti-Lock mode. During Anti-Lock braking, hydraulic pressure in the four wheel circuits is modulated to prevent any wheel from locking. Each wheel has a set of electrical solenoid valves and a hydraulic line to provide modulation, although for vehicle stability, both rear wheel valves receive the same electrical signal. The system can build, hold or reduce pressure at each wheel. Depending on the signals generated by the wheel speed sensors (WSS) at each wheel and received at the Controller-Anti-Lock Brake (CAB).

The ABS system represents the current state-of-the-art in vehicle braking systems and offers the driver increased safety and control during braking. This is accomplished by a sophisticated system of electrical and hydraulic components. That differ from conventional vacuum boosted hydraulic actuation systems. Because, there are several performance characteristics that may at first seem different but should be consid-

ered normal. These characteristics are discussed below. More technical details are discussed further in this section.

PEDAL FEEL

The ABS System uses hydraulic power assist for both normal power assisted braking and to provide a source of high pressure hydraulic fluid during Anti-Lock Braking. In general, pedal feel will be similar to that of a conventional vacuum boosted brake system. If during an Anti-Lock stop additional force is applied to the brake pedal, or the brake pedal is released and reapplied rapidly. The driver may notice a very hard pedal feel. This is due to normal isolation of the master cylinder during A.B.S. operation as wheel brake pressure is fed from the hydraulic booster.

ANTI-LOCK OPERATION

During Anti-Lock Braking, brake pressures are modulated by cycling electric valves. The cycling of these valves can be heard as a series of popping or ticking noises. In addition, the cycling may be felt as a pulsation in the brake pedal, although no pedal movement will be noticed. If Anti-Lock operation occurs during hard braking. Some pulsation may be felt in the vehicle body due to fore and aft movement of the vehicles suspension as brake pressures are modulated.

Although ABS operation is available at virtually all vehicle speeds. It will automatically turn off at speeds below 3 to 5 mph. Therefore wheel lock-up may be perceived at the very end of an Anti-Lock stop and should be considered normal.

TIRE NOISE & MARKS

Although the ABS system prevents complete wheel lock-up, some wheel slip is desired to achieve optimum braking performance. During brake pressure modulation, as brake pressure is increased, wheel slip is allowed to reach up to 30%. This means that the wheel rolling velocity is 30% less than that of a free rolling wheel at a given vehicle speed. This slip may result in some tire chirping, depending on the road surface. This sound should not be interpreted as total wheel lock-up.

Complete wheel lock-up normally leaves black tire marks on dry pavement. However, Anti-Lock Braking will not leave dark black tire marks since the wheel never reaches a locked condition. Tire marks may however be noticeable as light patched marks.

ABS EQUIPPED VEHICLE PERFORMANCE

Anti-Lock Brakes provide the driver with some steering control during hard braking. However there are conditions where the system does not provide any benefit. In particular, hydroplaning is still possible

when the tires ride on a film of water, resulting in the tire leaving the road surface rendering the vehicle almost uncontrollable. In addition, extreme steering maneuvers at high speed or high speed cornering beyond the limits of tire adhesion to the road surface may cause vehicle skidding, independent of vehicle braking. So, the ABS system is termed Anti-Lock instead of Anti-Skid.

One of the significant benefits of the ABS system is that of maintaining steering control during hard braking or during braking on slippery surfaces. It is therefore possible to steer the vehicle while braking on almost any road surface.

ABS SYSTEM SELF-DIAGNOSTICS

The ABS system has been designed with Self Diagnostic Capability. There are two self checks the systems performs every time the vehicle is started. First, when the key is turned on the system performs an electrical check called Start-Up Cycle. During this check, the Red Brake Warning Lamp and the Amber Anti-Lock Warning Lamp are illuminated. Then turned off at the end of the test, after about 1 to 2 seconds. When the vehicle reaches a speed of about 3 to 4 miles per hour. The system performs a functional check called Drive-Off. During Drive-Off, hydraulic valves are activated briefly to test their function. Drive-Off can be detected as a series of rapid clicks upon driving off the first time the car is started. If the brake pedal is applied during Drive-Off, the test is by-passed. Both of these conditions are a normal part of the system self test. Most fault conditions will set a ABS Fault Code in the (CAB), which can be retrieved to aid in fault diagnosis. Details can be found in Diagnosis Section.

WARNING SYSTEMS OPERATION

The ABS system uses two methods for notifying the driver of a system malfunction. These include the standard Red Brake Warning Lamp and an Amber Anti-Lock Warning Lamp, both located in the instrument cluster. The purpose of these two lamps are discussed in detail below.

RED BRAKE WARNING LAMP

The Red Brake Warning Lamp, located in the instrument cluster, will Turn On to warn the driver of brake system conditions that may result in reduced braking ability. The lamp is also turned on when the parking brake is not fully released. Conditions which may cause the Red Brake Warning Lamp to Turn On include:

- Parking brake not fully released. If the parking brake is applied or not fully released. The switch on the parking brake pedal assembly will ground the Red Brake Warning Lamp circuit and cause the lamp to turn on. On vehicles equipped with mechanical instru-

ment clusters, the Amber Anti-Lock Lamp will turn on if the vehicle is driven above 3 miles per hour with the Parking Brake applied.

- Low brake fluid. The fluid level sensor in the hydraulic assembly reservoir will ground the Red Brake Warning Lamp circuit if low brake fluid level is detected. In addition, ABS will be deactivated above 3 miles per hour and the Amber Anti-Lock Warning Lamp will be illuminated. If the vehicle is equipped with EVIC, a low fluid condition will also cause the Low Brake Fluid message to appear.

- Low accumulator pressure. In the event of low accumulator pressure, the dual function pressure switch in the hydraulic assembly will signal the (CAB) to ground the Red Brake Warning Lamp circuit. This will cause the Red Brake Warning Lamp to turn on. Low accumulator pressure may result in loss of power assist.

- Hydraulic assembly or (CAB) faults. The hydraulic assembly or (CAB) may turn on the Red Brake Warning Lamp. If certain faults are detected in either the hydraulic assembly or the (CAB), or the normal brake system.

- Bulb check. As a bulb check, the Red Brake Warning Lamp will illuminate whenever the ignition switch is placed in the crank position.

- **Illumination of the red Brake Warning Lamp may indicate reduced braking ability. A vehicle that has the Red Brake Warning Lamp ON should not be driven except to do diagnostic procedures described in Section 2 of this manual. Most conditions that turn on the Red Brake Warning Lamp will also turn on the Amber Anti-Lock Warning Lamp, consequently disabling the Anti-Lock function.**

ANTI-LOCK WARNING LAMP

The Anti-Lock Warning Lamp is located in the instrument cluster and is Amber in color. The Amber Anti-Lock Warning Lamp is illuminated when the (CAB) detects a condition that results in a shutdown of Anti-Lock function. The Amber Anti-Lock Warning Lamp is normally on until the (CAB) completes its self tests and turns the lamp off. For example, if the (CAB) is disconnected, the lamp is on.

Display of the Amber Anti-Lock Warning Lamp without the Red Brake Warning Lamp indicates only that Anti-Lock function has been disabled. Power assisted normal braking is unaffected.

NORMAL OPERATION OF WARNING LAMPS

With the ignition in the Crank position, the Red Brake Warning Lamp will turn on as a bulb check. The Amber Anti-Lock Warning Lamp will turn on for as little as 1 second to as long as 30 seconds.

If the car has not been started for several hours, for example after sitting overnight. The Red Brake Warning Lamp and the Amber Anti-Lock Warning

Lamp may both be turned on for as long as 60 seconds after turning the ignition on. This condition is caused by the loss of accumulator charge when the vehicle is parked for extended periods, particularly in cold weather. When the key is then turned on. The Pump/Motor assembly must recharge the hydraulic accumulator to its normal operating pressure. As recharging is completed, both warning lamps will remain on until accumulator pressure reaches about (1,000 psi). Both lamps should remain off at all other times, indicating normal operation.

ANTI-LOCK BRAKE SYSTEM COMPONENTS

The following is a detailed description of the Anti-Lock Brake System components. For information on servicing the other Non-ABS related components that may be referred to in this section. See the Standard Brakes Section that refers to the specific component.

HYDRAULIC ASSEMBLY

The ABS system uses an integral Hydraulic Assembly (Fig. 1) which includes a Booster/Master Cylinder, Modulator, Hydraulic Bladder Accumulator and Fluid Reservoir. The Hydraulic Assembly is located on the dash panel cowl on the drivers side of the vehicle. The following is a description of the components that make up the Hydraulic Assembly.

HYDRAULIC ASSEMBLY BRAKE FLUID RESERVOIR

A one piece Fluid Reservoir is attached to the hydraulic assembly with rubber seals. The Fluid Reservoir (Fig. 1) is internally separated into three fluid sections. Most of the brake fluid is contained in the Fluid Reservoir and hydraulic bladder accumulator (Fig. 1) Additional fluid is contained in the pump/motor assembly accumulator.

BOOSTER/MASTER CYLINDER

The Booster/Master Cylinder portion of the hydraulic assembly is an integral component and should never be disassembled.

The Booster/Master Cylinder uses a diagonally split configuration during normal braking. The two circuits are hydraulically isolated so a leak or malfunction in one circuit will allow continued braking ability in the other.

When force is applied to the brake pedal, the input pushrod applies force to the boost control valve. As the boost control valve is moved, it allows the pressurized fluid from the accumulator to flow into the master cylinder booster chamber. The pressure generated in the booster is directly proportioned to the brake pedal force exerted by the driver. This pressure in the booster servo in turn applies pressure to the primary master cylinder piston that in turn ap-

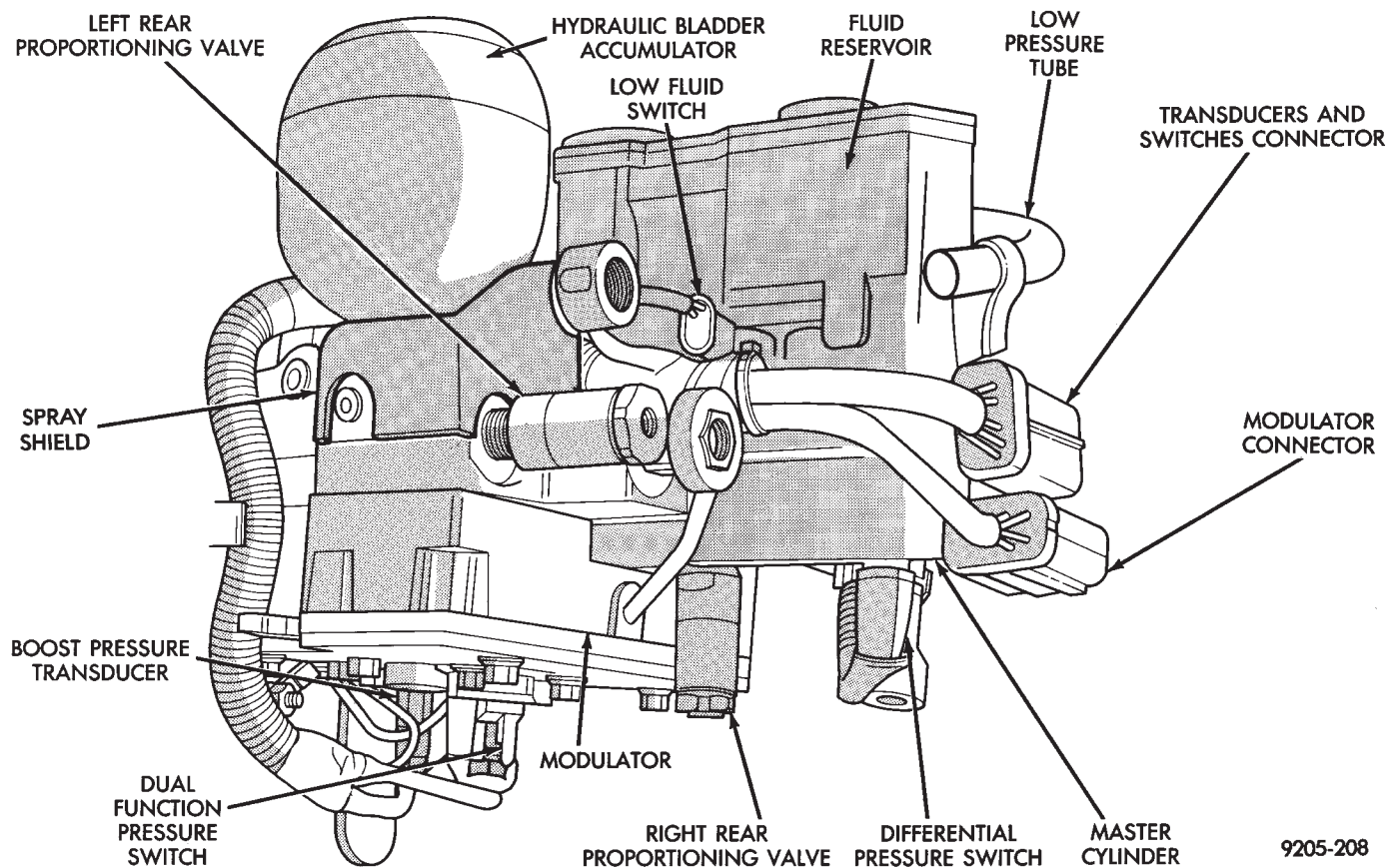

Fig. 1 Hydraulic Assembly

plies pressure to the secondary master cylinder piston. The pressure generated in the primary and secondary circuits are used to apply the brakes during normal braking.

WARNING: THE HYDRAULIC ACCUMULATORS CONTAIN BRAKE FLUID AND NITROGEN GAS AT HIGH PRESSURE. CERTAIN PORTIONS OF THE BRAKE SYSTEM ALSO CONTAIN BRAKE FLUID AT HIGH PRESSURE. REMOVAL OR DISASSEMBLY MAY RESULT IN PERSONAL INJURY AND IMPROPER SYSTEM OPERATION. REFER TO THE APPROPRIATE SERVICE MANUAL FOR PROPER SERVICE PROCEDURES.

HYDRAULIC BLADDER ACCUMULATOR

A Hydraulic Bladder Accumulator (Fig.2) is used to store brake fluid at high pressure. The pressurized fluid is used for Anti-Lock operation and for power assisted normal braking. The accumulator uses an elastomeric bladder configuration with a nitrogen pre-charge of about 6,895 kPa (1,000 psi.) With no brake fluid in the system, the nitrogen gas pre-charge applies approximately 6,895 kPa (1,000 psi.) to one side of the diaphragm (Fig. 2)

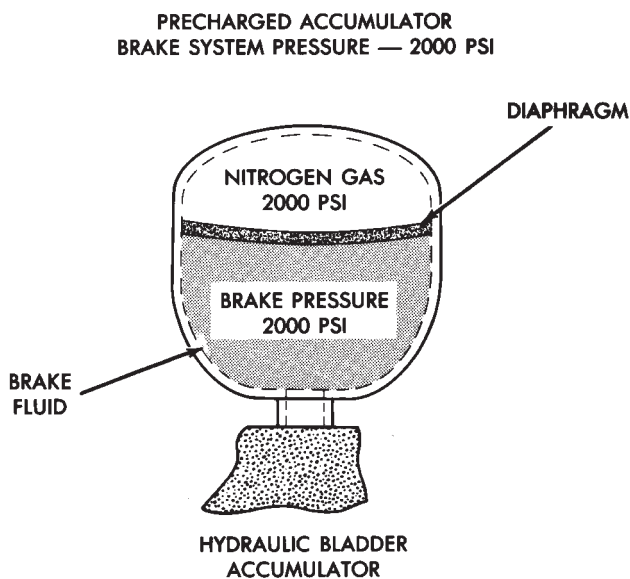

9205-209

Fig. 2 Hydraulic Fluid Accumulator

Under normal operation, the Pump/Motor assembly charges the accumulator to an operating pressure of between 11,032 and 13,790 kPa (1600 psi to 2,000 psi.) As pressurized brake fluid enters the accumulator, pushing against the opposite side of the diaphragm, (Fig. 2) the nitrogen gas is compressed and increases in pressure.

DUAL FUNCTION PRESSURE SWITCH

The Dual Function Pressure Switch is located on the bottom of the hydraulic assembly (Fig. 1) and monitors Accumulator Pressure. The Dual Function Pressure Switch, if found to be functioning improperly using the ABS diagnostics, can be replaced. See service procedure in Electronic Components area of On Car ABS Service in this section of the service manual. The primary function is to control operation of the Pump/Motor assembly and thus maintain proper accumulator operating pressure. When accumulator pressure falls to or below 11,032 kPa (1600 psi,) the Pump/Motor switch (internal to the dual function pressure switch) will close. This provides a ground, through Pin 1 of the Transducer and Switch, 10 way electrical connector to the Pump/Motor relay coil. The energized coil pulls the relay contacts closed, providing battery voltage to run the Pump/Motor. When Accumulator Pressure reaches 13,790 kPa (2,000 psi,) the switch opens, de-energizing the Pump/Motor Relay that turns off the Pump/Motor. **NOTE: THE (CAB) DOES NOT REGULATE OR CONTROL ACCUMULATOR PRESSURE.**

The second purpose of the Dual Function Pressure Switch is to provide a signal to the (CAB) when the Accumulator Pressure falls below 6,895 kPa (1,000 psi). A Warning Pressure Switch, internal to the Dual Function Pressure Switch, is normally closed above 6,895 kPa (1,000 psi.) This sends a ground signal to pin 17 at the (CAB). At or below 6,895 kPa (1,000 psi.) the Warning Pressure Switch opens. Internally, the (CAB) (pin 17) detects 12 volts and thus low pressure. At this warning pressure, the (CAB) will disable the Anti-Lock Braking functions, light the Red Brake Warning Lamp and the Amber Anti-Lock Warning Lamp. After two minutes of continuous detection, a low accumulator fault is stored.

Grounding for the Dual Function Pressure Switch. Is provided through Pin 1 of the Transducer and Switch, 10 way electrical connector and the Modulator Assembly.

DUAL FUNCTION PRESSURE SWITCH WIRING DIAGRAM

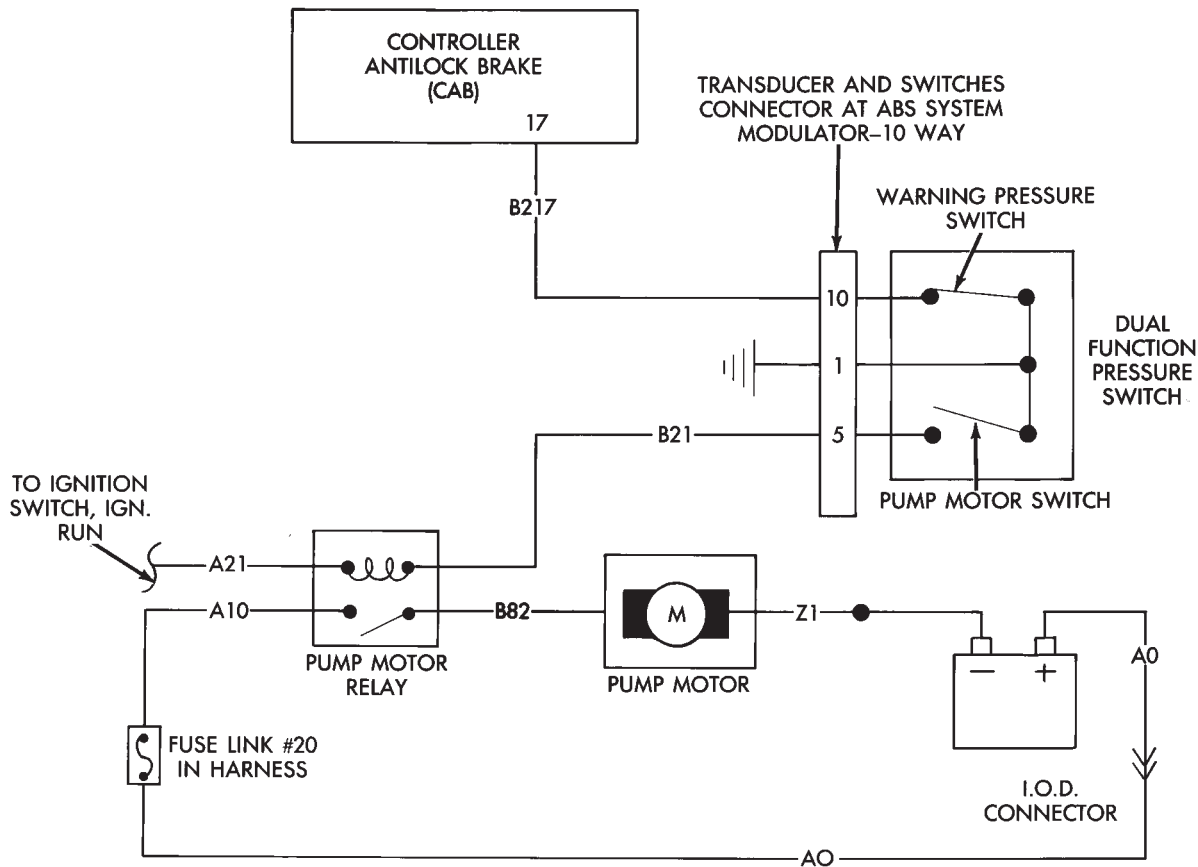

9105-103

PRESSURE TRANSDUCERS

Two Pressure Transducers are used for brake system fault detection. Both transducers generate a voltage signal (between 0.25 volts and 5.0 volts) that is proportional to pressure. These signals are compared by the (CAB) and used to detect brake system faults that would require Anti -Lock Braking to be disabled.

The Boost Pressure Transducer is mounted on the bottom of the hydraulic assembly, (Fig. 1) and monitors booster servo pressure. The Primary Pressure Transducer is mounted on the left side of the hydraulic assembly and monitors primary master cylinder pressure.

DIFFERENTIAL PRESSURE SWITCH

A non-latching Differential Pressure Switch is used to detect a pressure difference greater than 2,068 kPa (300 psi.) between the primary and secondary master cylinder hydraulic circuits. If detected, the Differential Pressure Switch grounds the output of the primary pressure transducer (circuit B-218). This results in a 0.0 volt signal from the Primary Pressure Transducer that is sensed by the (CAB) as a differential pressure fault. The (CAB) will then light the Red Brake Warning Lamp and the Amber Anti-Lock Warning Lamp and disable the Anti-Lock braking function. See Fig. 1 for location of the differential pressure switch.

PROPORTIONING VALVES

The ABS system uses screw-in Proportioning Valves in place of the conventional Height Sensing Proportioning Valve. Each rear brake circuit has its own screw-in Proportioning Valve that is attached to the rear brake outlet ports of the hydraulic assembly (Fig. 1). These valves limit brake pressure to the rear brakes after a certain brake pressure is reached. This improves front to rear wheel brake balance during normal braking.

FILTERS-SERVICEABILITY

There is a screen filter in each of the two master cylinder fill ports. There is also a low pressure filter for the pump/motor. The filter is integral to the Pump/Motor low pressure hose.

FLUID LEVEL SWITCH

A Low Fluid Switch is located in the hydraulic assembly fluid reservoir, (Fig. 1). The switch consists of a float and magnetic reed switch that closes when low fluid is detected. The Low Fluid Switch is used as an input, to the Red Brake Warning Lamp, the (CAB), and the EVIC (if so equipped). When a low

PRESSURE SWITCH AND PRESSURE TRANSDUCER WIRING

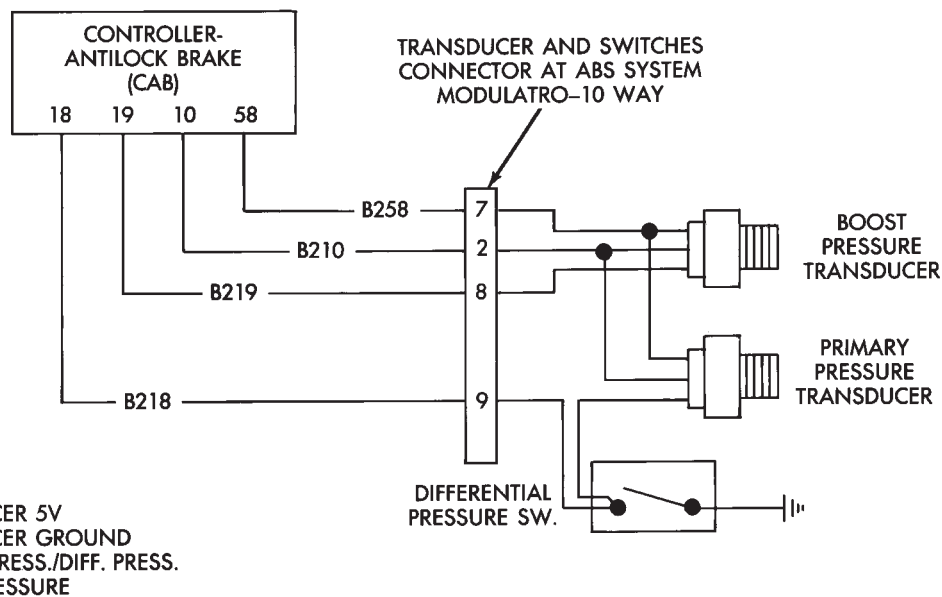

9105-104

fluid condition exists the switch will close, grounding the low fluid circuit and illuminating the Red Brake Warning Lamp. The (CAB) will disable the Anti-Lock Function and light the Amber Anti-Lock Warning Lamp if the vehicle is in motion above 3 mph. If the vehicle is not in motion, the Amber Anti-Lock Warning Lamp will NOT be lit.

PUMP/MOTOR ASSEMBLY

The Pump/Motor Assembly is mounted to the transaxle below the hydraulic assembly, (Fig. 3). Integral to the Pump/Motor Assembly is an accumulator using a sliding piston configuration with a nitrogen pre-charge of 3,172 kPa (460 psi.) The Pump/Motor is an electrically driven pump that takes low pressure brake fluid from the hydraulic assembly fluid reservoir and pressurizes it. The pressurized fluid is then stored in the piston accumulator and hydraulic bladder accumulator for power assist and Anti-Lock Braking. Operation of the Pump/Motor is controlled by the Dual Function Pressure Switch through the Pump/Motor Relay. **The (CAB) does NOT control the Pump/Motor activation.** Rubber isolators are used to mount the pump to its bracket for noise isolation. The Pump/Motor Assembly is connected to the Hydraulic Assembly with a low pressure return hose and a high pressure hose. A filter is located in the low pressure return line.

WHEEL SPEED SENSORS

One Wheel Speed Sensor (WSS), is located at each wheel (Fig. 4, 5 and 6) and sends a small (AC) electrical signal to the control module (CAB). This signal is generated by magnetic induction. The magnetic induction is created when a toothed sensor ring (Tone Wheel) passes by the stationary magnetic (Wheel Speed Sensor). The (CAB) converts the (AC) electrical signal

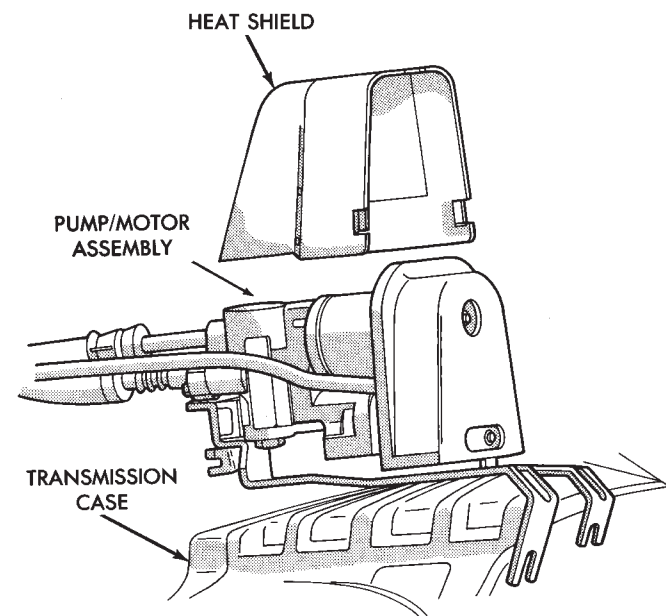

9105-26

Fig. 3 Pump/Motor Assembly And Heat Shield

generated at each wheel into a digital signal. If a wheel locking tendency is detected, the (CAB) will then modulate hydraulic pressure to prevent the wheel(s) from locking.

The front Wheel Speed Sensor (Fig. 4) is mounted to a boss on the steering knuckle, for both the Front Wheel Drive and All Wheel Drive applications. The Tone Wheel is part of the outboard constant velocity joint housing.

The Rear Wheel Speed Sensor, on Front Wheel Drive applications. Is mounted to the rear brake

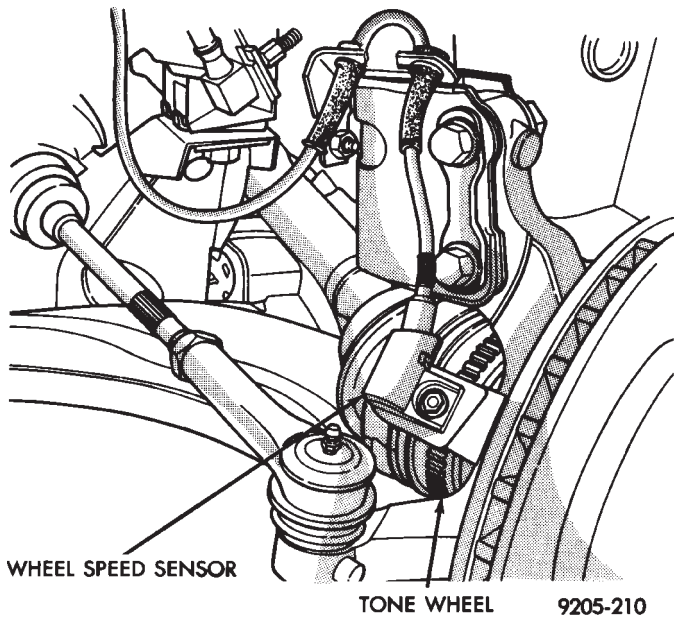

Fig. 4 Front Wheel Speed Sensor FWD/AWD

Backing Plate (Fig. 5). And the rear Tone Wheel is an integral part of the rear wheel brake drum (Fig. 6).

The All Wheel Drive, rear wheel speed sensor is

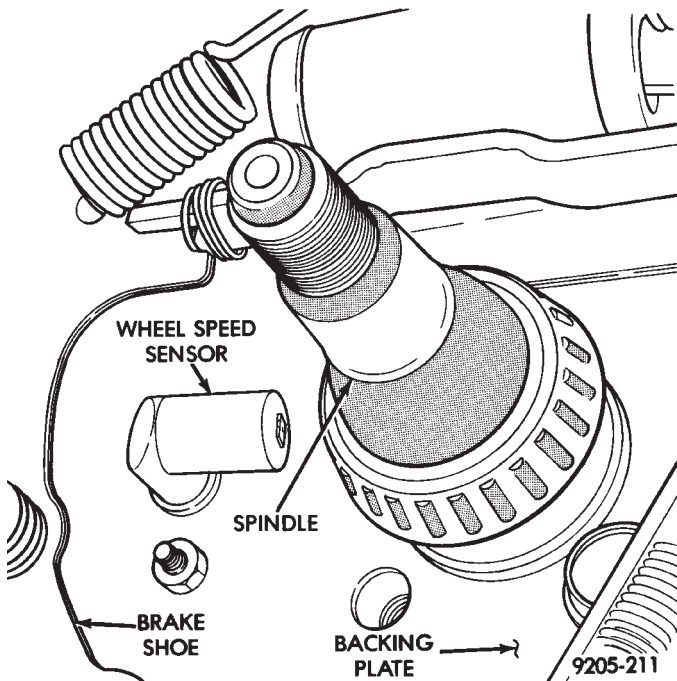

Fig. 5 Rear Wheel Speed Sensor FWD

mounted to the rear carrier axle (Fig. 7). The Rear Tone Wheel on this application is part of the outboard constant velocity joint housing.

The speed sensor, to tone wheel air gap all applications is NOT adjustable.

All four, Wheel Speed Sensors are serviced individually as replaceable components. The Front Wheel Drive and All Wheel Drive front Tone Wheels are serviced as an assembly with the front outboard constant velocity

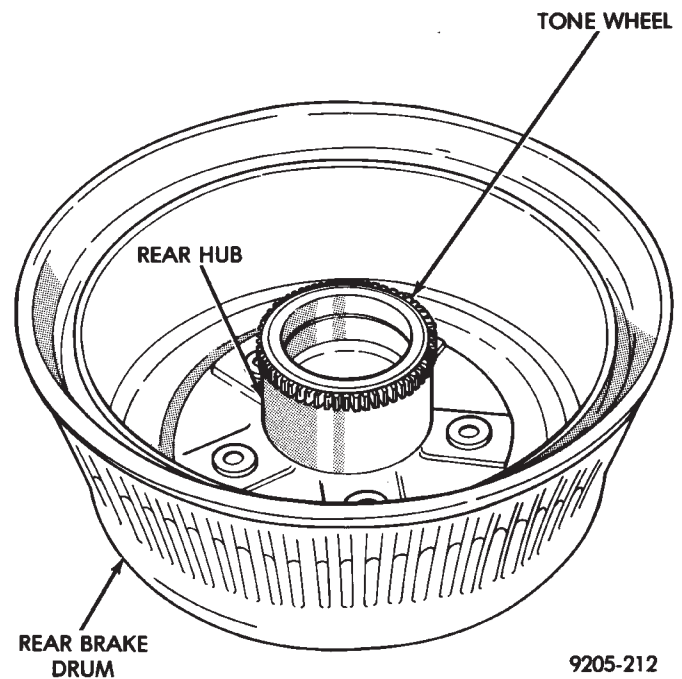

Fig. 6 Rear Tone Wheel FWD

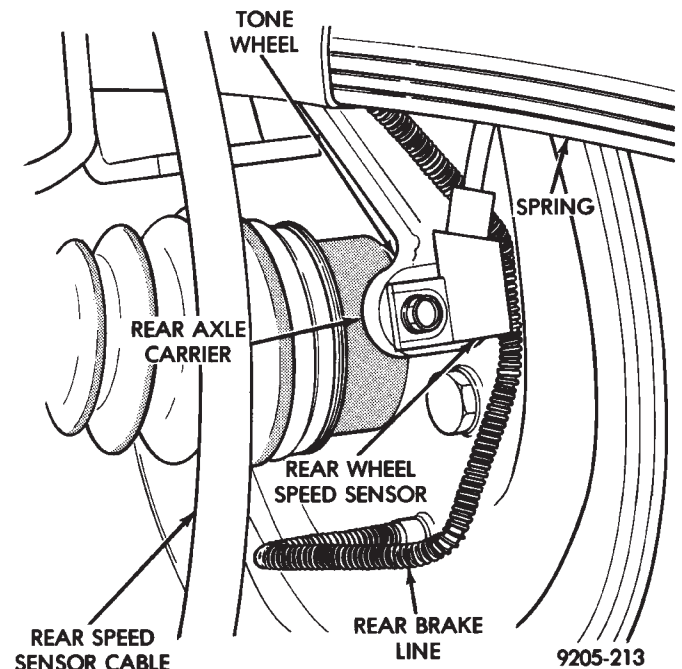

Fig. 7 Rear Wheel Speed Sensor AWD

joint housing. The Front Wheel Drive rear Tone Wheels are serviced as an assembly with the rear brake drum hub. The All Wheel Drive rear Tone Wheels are serviced as an assembly with the rear outboard constant velocity joint housing.

Correct Anti-Lock System operation is dependent on wheel speed signals from the wheel speed sensors. The vehicles' wheels and tires must all be the same size and type to generate accurate signals. In addition, the tires must be inflated to the recommended

pressures for optimum system operation. Variations in wheel and tire size or significant variations in inflation pressure can produce inaccurate wheel speed signals.

CONTROLLER ANTI-LOCK BRAKE (CAB)

The Anti-Lock Brake Controller is a small microprocessor based device that monitors the brake system and controls the system while it functions in Anti-Lock Mode. The CAB is located under the battery tray (Fig. 8) and uses a 60-way system connector. The power source for the CAB is through the ignition switch to pin 60 of the controller. **THE FRONT WHEEL DRIVE CONTROLLER IS DIFFERENT FROM THE ALL WHEEL DRIVE CONTROLLER. IF THE CONTROLLER NEEDS TO BE REPLACED BE SURE THE CORRECT CONTROLLER IS USED. THE CONTROLLER ANTI-LOCK BRAKE (CAB) IS NOT ON THE CCD BUS**

The primary functions of the (CAB) are:

- (1) Detect wheel locking tendencies.

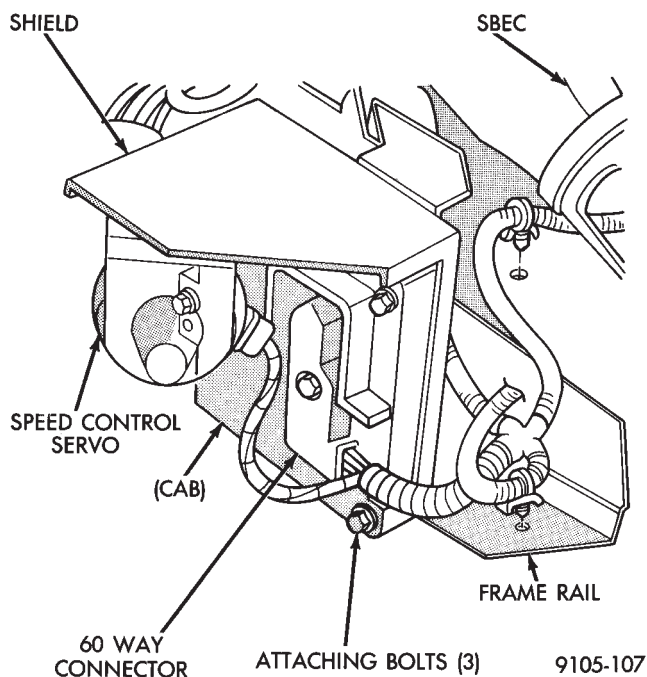

Fig. 8 Location Controller Anti-Lock Brake (CAB)

- (2) Control fluid modulation to the brakes while in Anti-Lock mode.
- (3) Monitor the system for proper operation.
- (4) Provide communication to the DRB II while in diagnostic mode.

The (CAB) continuously monitors the speed of each wheel, through the signals generated at the Wheel Speed Sensors, to determine if any wheel is beginning to lock. When a wheel locking tendency is detected, the

(CAB) will isolate the master cylinder from the wheel brakes. This is done by activating the Isolation Valves. The (CAB) then commands the appropriate Build or Decay valves to modulate brake fluid pressure in some or all of the hydraulic circuits. The fluid used for modulation comes from the booster servo circuit. The (CAB) continues to control pressure in individual hydraulic circuits until a locking tendency is no longer present.

The (ABS) system is constantly monitored by the (CAB) for proper operation. If the (CAB) detects a fault, it can disable the Anti-Lock braking function. Depending on the fault, the (CAB) will light one or both of the brake warning lamps.

The (CAB) contains a System Diagnostic Program which triggers the brake system warning lamps when a system fault is detected. Faults are stored in a diagnostic program memory. There are 19 fault codes that may be stored in the (CAB) and displayed through the DRB II. These fault codes will remain in the (CAB) memory even after the ignition has been turned off. These fault codes will remain in memory until they are cleared with the DRB II, or automatically erased from the memory after (50) ignition switch on/off cycles.

CONTROLLER ANTI-LOCK BRAKE (INPUTS)

- Four wheel speed sensors.
- Boost pressure transducer.
- Primary pressure transducer.
- Low fluid level switch.
- Differential pressure switch.
- Parking brake switch.
- Dual function pressure switch (warning pressure only)
- Stop lamp switch.
- Ignition switch.
- System relay voltage.
- Ground.
- Low Accumulator

CONTROLLER ANTI-LOCK BRAKE (OUTPUTS)

- Ten modulator valves-3 decay, 3 build and 4 isolation.
- Red Brake warning lamp.
- Amber Anti-Lock Warning Lamp.
- System relay actuation.
- Diagnostic communication.

ABS SYSTEM DIAGNOSTIC CONNECTOR

The Bendix Anti-Lock system diagnostic connector is located under the lower dash panel or in the area of the fuse box. The fuse box is located behind the access panel that is on the bottom portion of the dash panel, left of the steering column. The diagnostics connector is a blue 6 way connector.

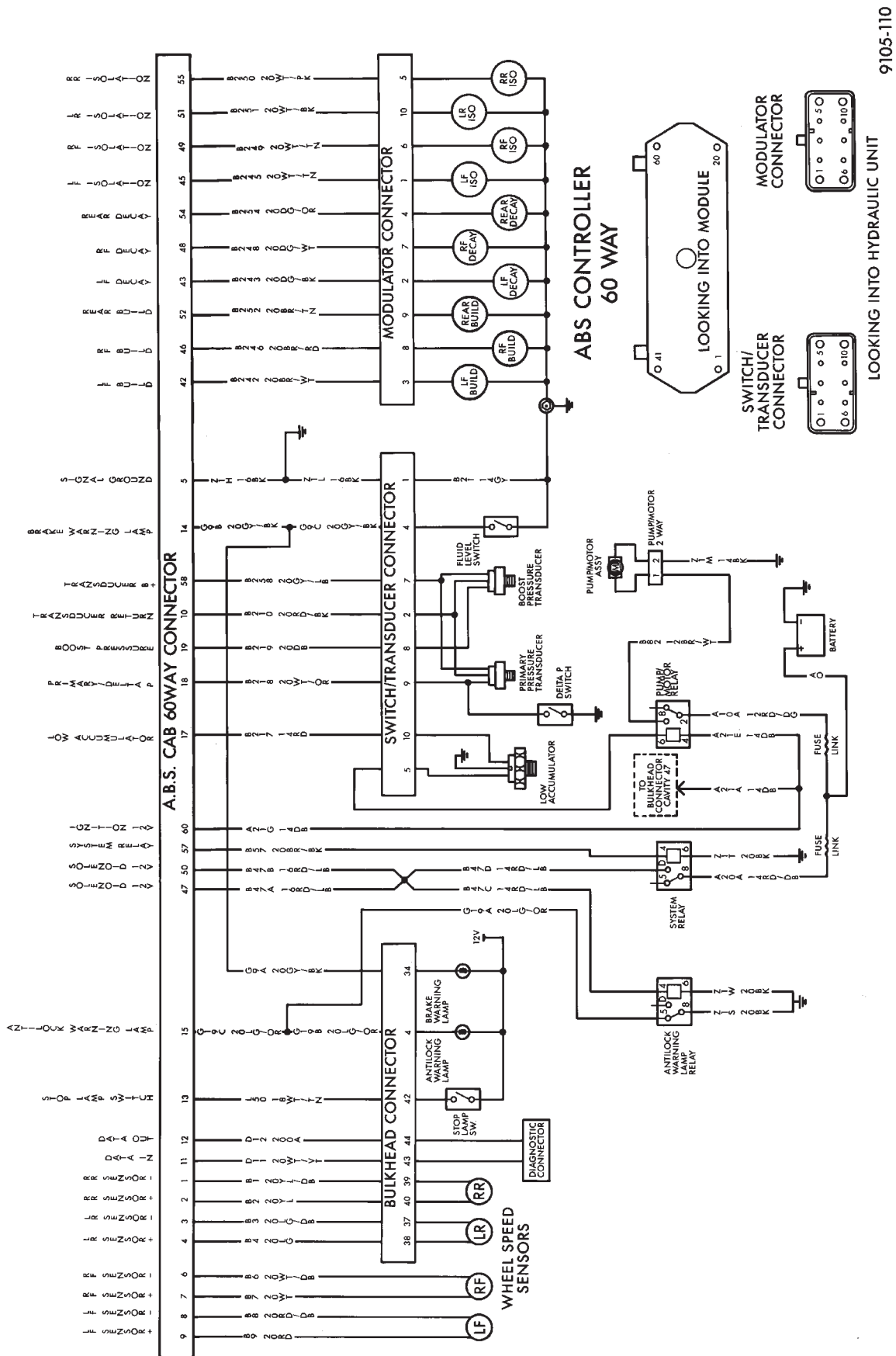

9105-110

ABS SYSTEM WIRING SCHEMATIC

ANTI-LOCK SYSTEM RELAYS AND WARNING LAMPS

PUMP/MOTOR RELAY

Pump/Motor power is supplied by the Pump/Motor Relay. The Pump/Motor relay is located in front of the left shock tower (Fig. 9). The relay coil is energized by a ground from the Dual Function Pressure Switch.

SYSTEM RELAY

The (ABS) Modulator Valves and Anti-Lock Warning Lamp Relay are controlled through a System Relay. The System relay is located on the top left inner fender behind the headlight (Fig. 9). The system relay provides power to the (CAB) for modulator valve operation (pins 47 and 50) after the start-up cycle when the ignition is turned on.

ANTI-LOCK WARNING LAMP RELAY

The Anti-Lock Warning Lamp is controlled by the Yellow Light Relay. See (Fig. 9) for location behind the left headlight. With the relay de-energized, the lamp is lit. When the system relay is energized by the (CAB), the Anti-Lock Warning Lamp relay is energized, and the lamp is turned off. Thus, the lamp will be lit if the (CAB) is disconnected or if a system fault causes (ABS) function to be turned off, or if the system relay fails open.

ANTI-LOCK WARNING LAMP OFF

System Relay (normally open) and Yellow Light Relay (normally closed) Energized.

From pin 57 the (CAB) energizes the system relay coil. The current flow in the coil closes the system relay. Current is then provided to pins 47 and 50 of the (CAB) to provide power to the modulator valves. This current also energizes the Yellow Light Relay coil. The current flow in the yellow light relay coil opens the Anti-Lock Warning Lamp Relay Switch. This breaks the ground path to the Anti-Lock Warning Lamp and the lamp is turned off.

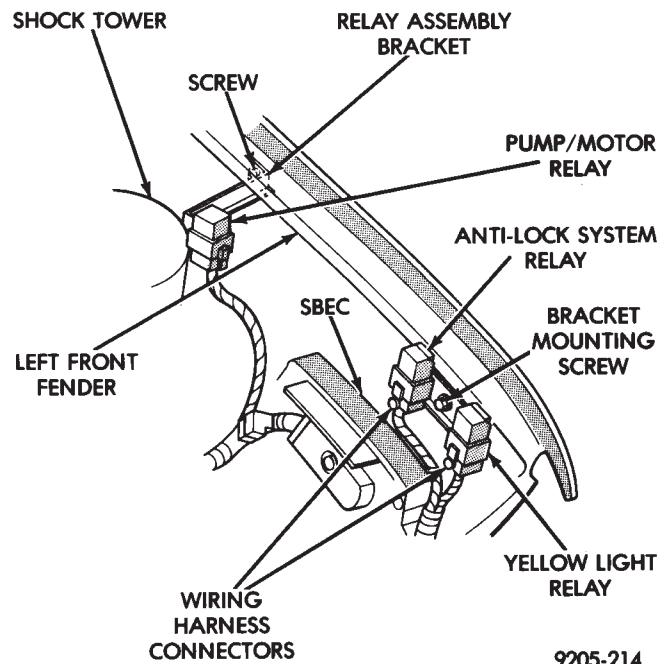

Fig. 9 Pump/Motor and Anti-Lock System Relays

The (CAB) by itself, also can turn on the Anti-Lock Warning Lamp. The (CAB) can turn on the Anti-Lock Warning Lamp by providing a ground at pin 15.

ANTI-LOCK WARNING LAMP ON

System Relay and Anti-Lock Warning Lamp Relay De-Energized.

When the Amber Anti-Lock Warning Lamp is on, there is no current flow from the (CAB) at pin 57. The system relay coil is NOT energized. No current flows to pins 47 and 50 (modulator valve power), or to the Anti-Lock Warning Lamp relay coil. Thus, the Anti-Lock Warning Lamp Relay is not energized. The Anti-Lock Warning Lamp is grounded through the Anti-Lock Warning Lamp relay contacts. The Anti-Lock Warning Lamp is illuminated.



9205-215

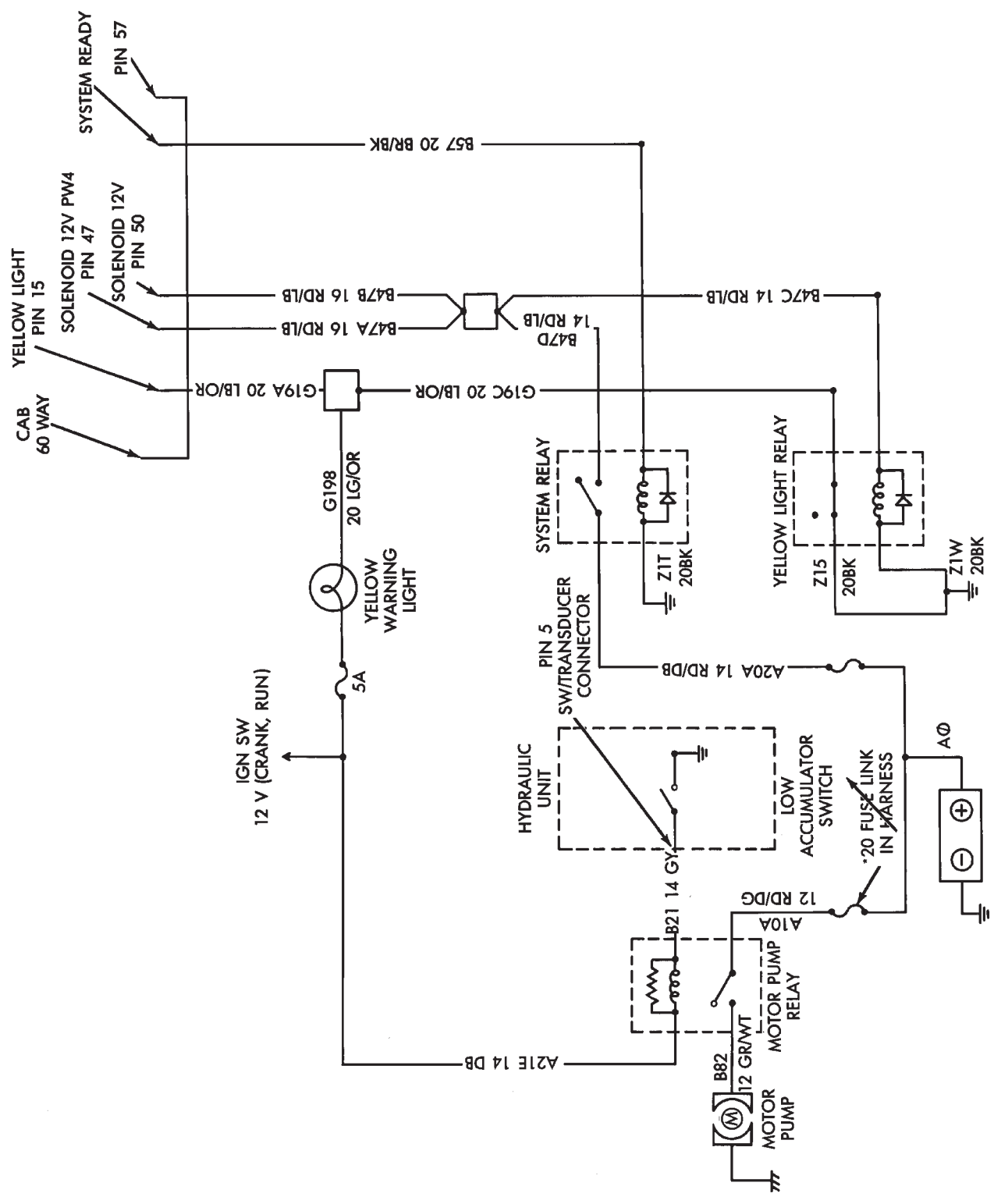

ANTI-LOCK SYSTEM RELAY WIRING SCHEMATIC

ABS HYDRAULIC CIRCUITS AND VALVE OPERATION

Through the following operation descriptions and diagrams. The function of the various hydraulic control valves in the ABS system will be described. The fluid control valves mentioned below, control the flow of pressurized brake fluid to the wheel brakes during the different modes of Anti-Lock Braking.

NORMAL BRAKING

ISOLATION VALVES

Open to primary and secondary master cylinder brake fluid supply (Fig. 10)

DECAY AND BUILD VALVES

Closed, not allowing for the build-up or release of brake fluid supply (Fig. 10).

The brake pedal is applied. The travel of the brake pedal closes primary, secondary and booster servo circuits from fluid supply at the fluid reservoir. Brake fluid from the primary and secondary circuits flows through the open isolation valves and applies the wheel brakes. Fluid from the booster servo circuit does

not flow to the wheel brakes. The fluid flow is blocked by the closed build valves and check valves.

POWER ASSIST

The boost control valve shuttles between its three positions to provide power assisted braking (Fig. 10).

ABS BRAKING-BUILD PRESSURE

ISOLATION VALVES

Closed, isolating wheel brakes from master cylinder primary and secondary fluid supplies and open to booster servo circuit pressure through open build valves (Fig. 11)

DECAY VALVES

Closed, not allowing the escape of pressurized fluid supply from the hydraulic system (Fig. 11).

BUILD VALVES

Open, allowing booster servo circuit pressure to flow to wheel brakes through the isolation valves (Fig. 11).

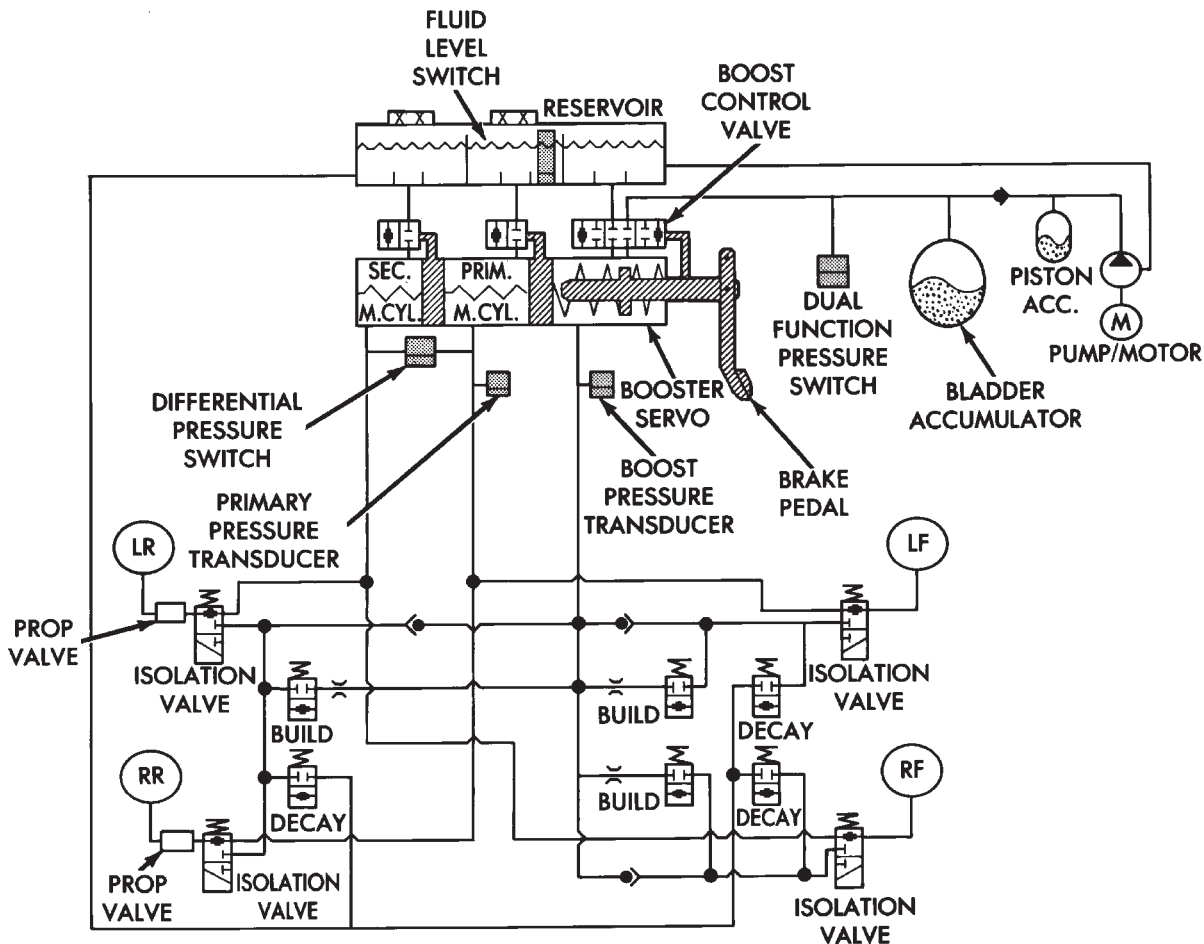
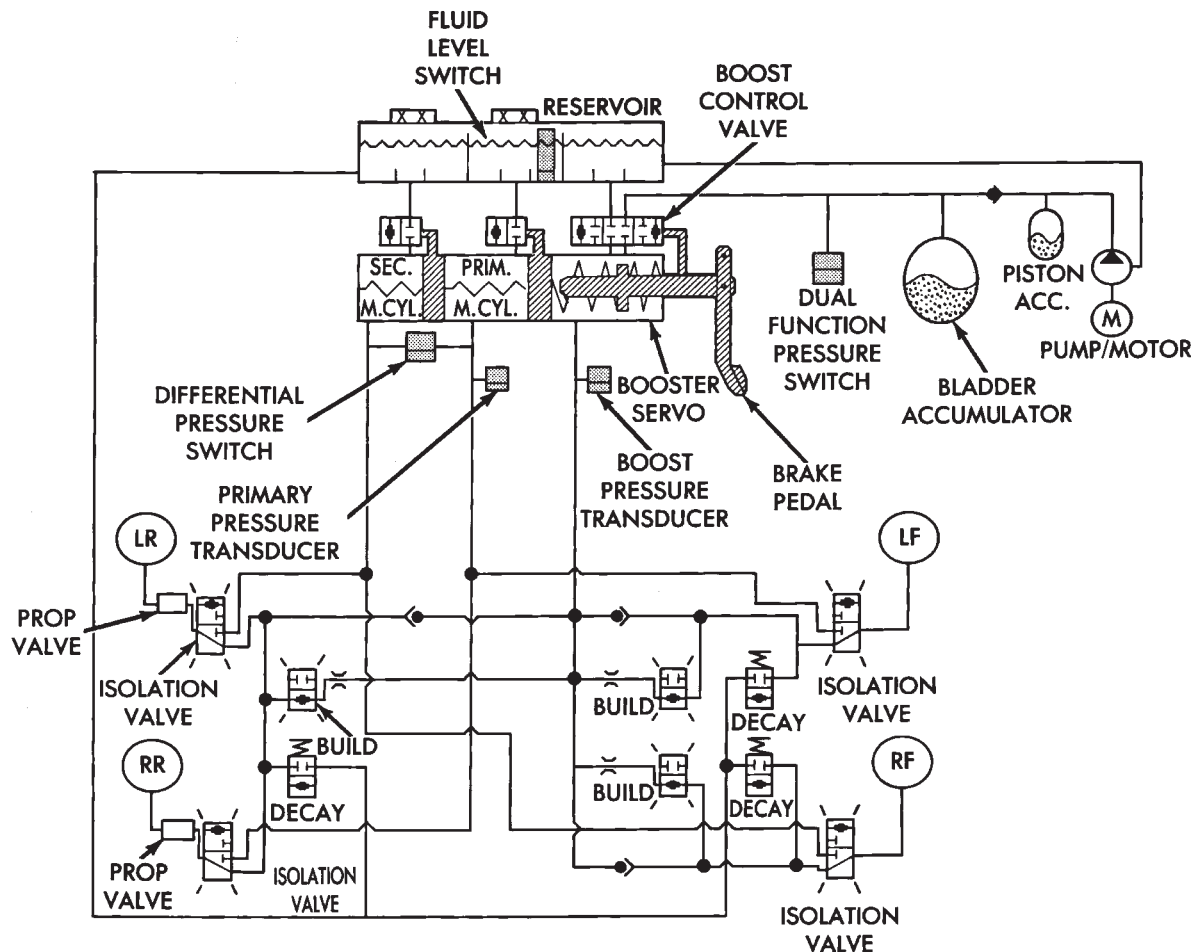

Fig. 10 Normal Braking - Hydraulic Control



9105-19

Fig. 11 Build Pressure - Hydraulic Control

POWER ASSIST

The boost control valve shuttles between its three positions to provide power assisted braking (Fig. 11).

ABS BRAKING-HOLD PRESSURE

For explanation purposes we will assume all speed sensors are sending the same wheel speed information, requiring the same modulation at the same rate.

ISOLATION VALVES

Closed, isolating the wheel brakes from the master cylinder primary and secondary fluid supplies. Build and decay valves are closed preventing any fluid from reaching the open isolation valves (Fig. 12).

DECAY AND BUILD VALVES

Closed, not allowing fluid supply to reach the open isolation valves (Fig. 12).

ABS BRAKING-DECAY PRESSURE

ISOLATION VALVES

Closed, isolating the wheel brakes from the master cylinder primary and secondary fluid supplies (Fig. 13)

DECAY VALVES

Open, allowing release of fluid pressure through decay valve to the fluid reservoir (Fig. 13)

BUILD VALVE

Closed, blocking booster servo circuit fluid to wheel brakes (Fig. 13).

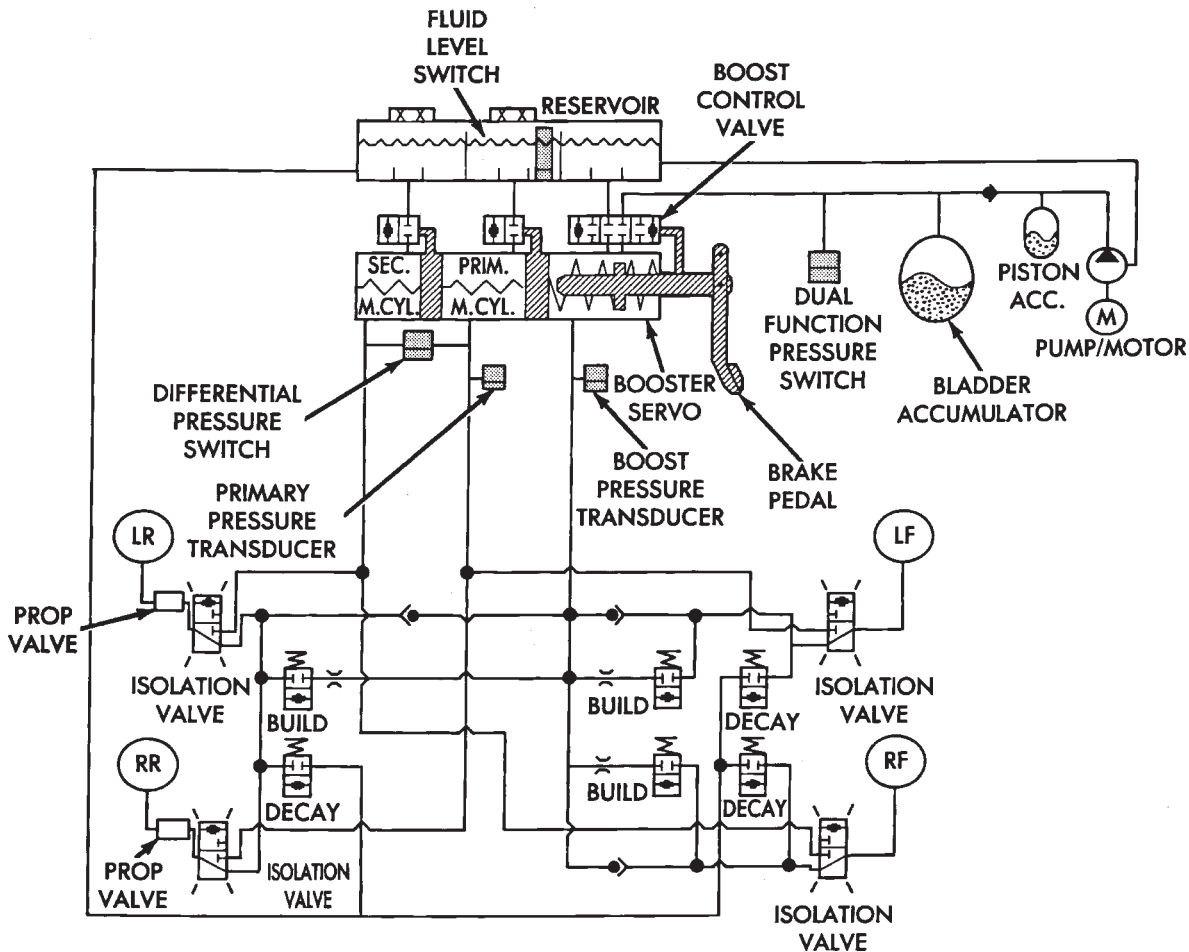

9105-17

Fig. 12 Hold Pressure - Hydraulic Control

ABS BRAKING SYSTEM DIAGNOSIS

WARNING: SOME OPERATIONS IN THIS SECTION REQUIRE THAT HYDRAULIC TUBES, HOSES AND FITTINGS BE DISCONNECTED FOR INSPECTION OR TESTING PURPOSES. THIS BRAKE SYSTEM USES A HYDRAULIC ACCUMULATOR THAT, WHEN FULLY CHARGED, CONTAINS BRAKE FLUID AT HIGH PRESSURE. BEFORE DISCONNECTING ANY HYDRAULIC TUBE, HOSE OR FITTING. BE SURE THAT THE ACCUMULATOR IS FULLY DE-PRESSURIZED AS DESCRIBED IN THIS SECTION. FAILURE TO DE-PRESSURIZE THE ACCUMULATOR MAY RESULT IN PERSONAL INJURY AND/OR DAMAGE TO PAINTED SURFACES.

CAUTION: Certain components of the Anti-Lock Brake System (ABS) are not intended to be serviced individually. Attempting to remove or disconnect certain system components, may result in personal injury and/or improper system operation. Only those components with approved removal, service and installation procedures described in this manual should be serviced.

GENERAL INFORMATION

This section contains information necessary for diagnosis of mechanical conditions that can affect the operation of the Bendix Anti-Lock 10 Brake System. Specifically, this section should be used to help diagnose mechanical conditions that result in any of the following:

CAUTION: Review this entire section before performing any mechanical work on a vehicle equipped with the Bendix Anti-Lock 10 brake system. For information on precautions pertaining to potential component damage, vehicle damage and personal injury.

- (1) Anti-Lock warning lamp illuminated
- (2) BRAKE warning lamp on
- (3) Lack of Power Assist or Excessive Pedal Travel
- (4) Brakes Lock on Hard Application

Diagnosis of conditions that are obviously mechanical in nature. Such as brake noise, brake pulsation, or vehicle vibration during normal braking. Should be directed to Group 5 Brakes in the service manual. This also pertains to problems involving the parking brake system.

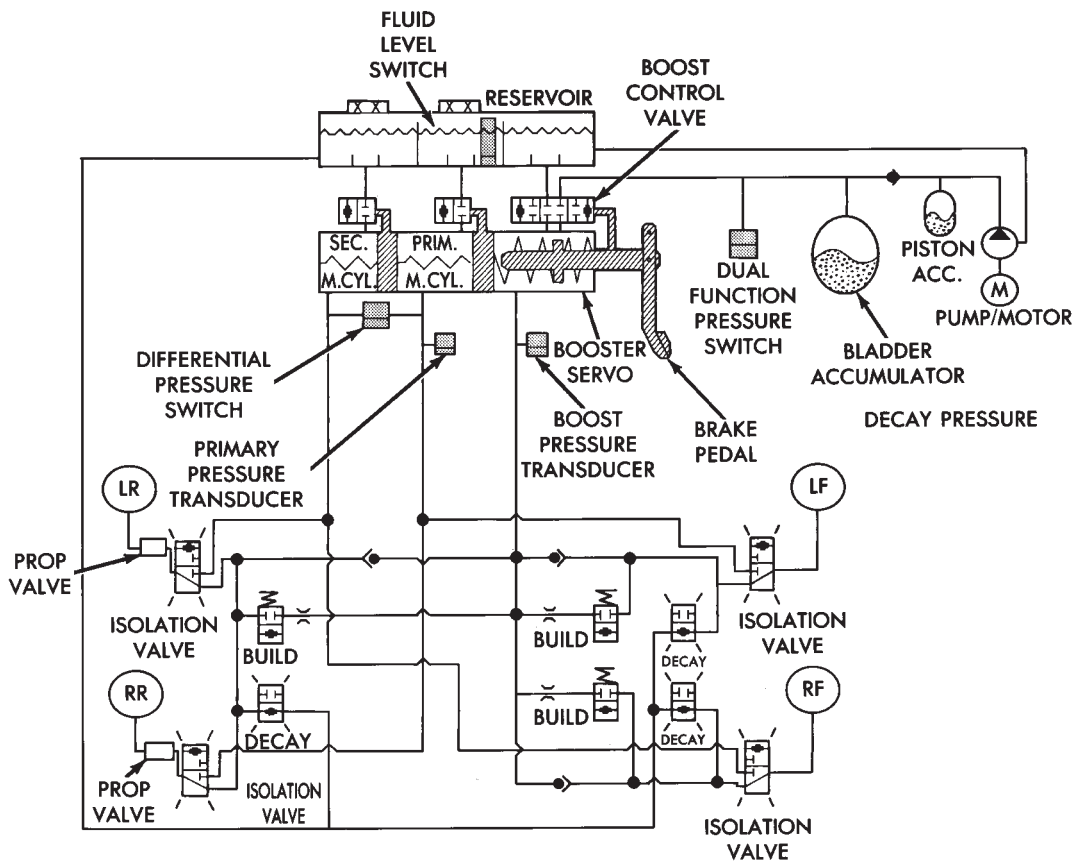

9105-20

Fig. 13 Decay Pressure - Hydraulic Control

In order to effectively diagnose an Anti-Lock Brake System (ABS) condition. It is important to read Section 1 of this manual, Anti-Lock Brake System Description. This section will give you information on the function of the ABS components. Then follow the diagnostic procedures outlined in this section.

Many conditions that generate customer complaints may be normal operating conditions, but are judged to be a problem due to unfamiliarity with the ABS system. These conditions can be recognized without performing extensive diagnostic work. Given adequate understanding of the operating principles and performance characteristics of the ABS system. See Section 1 of this manual to familiarize yourself with the operating principles of the ABS system.

DEFINITIONS

Several abbreviations are used in this manual. They are presented here for reference.

- CAB—Controller Anti-Lock Brake
- ABS—Anti-Lock Brake System
- PSI—Pounds per Square Inch (pressure)
- WSS—Wheel Speed Sensor

ABS CONTROLLER ANTI-LOCK BRAKE (CAB) SERVICE PRECAUTIONS

The ABS system uses an electronic control module, the (CAB). This module is designed to withstand nor-

mal current draws associated with vehicle operation. However care must be taken to avoid overloading the (CAB) circuits. In testing for open or short circuits, do not ground or apply voltage to any of the circuits unless instructed to do so by the appropriate diagnostic procedure. These circuits should only be tested using a high impedance multi-meter, special tools or the DRB II tester as described in this section. Power should never be removed or applied to any control module with the ignition in the ON position. Before removing or connecting battery cables, fuses, or connectors, always turn the ignition to the OFF position.

ABS SYSTEM GENERAL SERVICE PRECAUTIONS

TEST DRIVING ABS COMPLAINT VEHICLES

Most ABS complaints will require a test drive as a part of the diagnostic procedure. The purpose of the test drive is to duplicate the condition.

Before test driving a brake complaint vehicle, especially if the Red Brake Warning Lamp is on, test the brakes at low speed to be sure that the car will stop normally. Remember that conditions that result in illumination of the Red Brake Warning Lamp may indicate reduced braking ability. The following procedure should be used to test drive an ABS complaint:

(1) Ignition on. Turn the ignition to the ON position without starting the car and wait until the Red Brake Warning Lamp and Amber Anti-Lock Warning Lamp turn off. This will allow the pump to charge the accumulator to operating pressure. If the warning lamp(s) do not turn off, go to step 3.

(2) Ignition off for 15 seconds.

(3) Start car. Wait for displays to return to normal operating mode before proceeding.

(4) With Shift lever in PARK, slowly depress brake pedal and release.

(5) Drive vehicle a short distance. During this test drive, be sure that the vehicle achieves at least 20 mph. Then brake to at least one complete stop and accelerate slowly back up to at least 20 mph.

(6) If a functional problem with the A.B.S. system is determined while test driving a vehicle. Refer to the Bendix Anti-Lock 10 Diagnostics Manual for required test procedures and proper use of the DRB II tester.

CAUTION: The following are general precautions that should be observed when servicing and diagnosing the ABS system and/or other vehicle systems. Failure to observe these precautions may result in ABS system damage.

(1) If welding work is to be performed on the vehicle using an arc welder, the (CAB) should be disconnected before the welding operation begins.

(2) The (CAB) and hydraulic assembly 10 way connectors should never be connected or disconnected with the ignition on.

(3) Some components of the ABS system are not serviced separately and must be serviced as complete assemblies. Do not disassemble any component which is designated as non-serviceable.

(4) **Always de-pressurize the Hydraulic Accumulator when performing any work that requires disconnecting any hydraulic tube, flex hose or fitting. The ABS system uses brake fluid at high pressure. Failure to de-pressurize the accumulator may result in personal injury and/or damage to painted surfaces.**

Brake fluid will damage painted surfaces. If brake fluid is spilled on any painted surfaces, wash off with water immediately.

DE-PRESSURIZING HYDRAULIC ACCUMULATOR

The ABS pump/motor assembly keeps the hydraulic accumulator charged between approximately 11,032 and 13,790 kPa (1600 and 2000 psi) anytime the ignition is in the ON position. The pump/motor assembly cannot run if the ignition is off or if either battery cable is disconnected.

Unless otherwise specified, the hydraulic accumulator should be de-pressurized before disassembling any

portion of the hydraulic system. The following procedure should be used to de-pressurize the hydraulic accumulator:

(1) With ignition off, or either battery cable disconnected, pump the brake pedal a minimum of 40 times using approximately 50 pounds of pedal force. A noticeable change in pedal feel will occur when the accumulator becomes discharged.

(2) When a definite increase in pedal effort is felt, pump the pedal a few additional times. This will insure removal of all hydraulic pressure from the brake system.

WHEEL SPEED SENSOR CABLES

Proper installation of wheel speed sensor cables is critical to continued ABS system operation. Be sure that cables are installed and routed properly. Failure to install cables in their retainers, as shown in Section 3 of this manual. May result in contact with moving parts or over extension of cables, resulting in an open circuit.

MECHANICAL DIAGNOSTICS AND SERVICE PROCEDURES

SPECIAL SERVICE TOOLS

Some diagnostic procedures in this section require the use of special service tools. Each of these tools is described below.

DRB II DIAGNOSTIC TESTER

Some of the diagnostic procedures that are explained in this section require the use of the DRB II DIAGNOSTICS TESTER to insure that proper diagnostics are performed. Refer to those sections for proper testing procedures and the DRB II manual for its proper operational information.

MST-6163 PRESSURE TESTER

Some diagnostic procedures in this manual require the use of the MST-6163 pressure gauge and adaptor (Fig. 1) to measure accumulator pressure during certain phases of operation. The pressure gauge and adaptor should be installed as follows:

(1) De-pressurize the accumulator by pumping the brake pedal a minimum of 40 times with the ignition off. The procedure is fully explained under De-Pressurizing Hydraulic Accumulator which is described earlier in this System Diagnosis Section.

WARNING: FAILURE TO DE-PRESSURIZE THE ACCUMULATOR PRIOR TO PERFORMING THIS OPERATION MAY RESULT IN PERSONAL INJURY AND/OR DAMAGE TO PAINTED SURFACES.

(2) Remove hydraulic assembly accumulator port plug, located on right hand side of hydraulic assembly (Fig. 1).

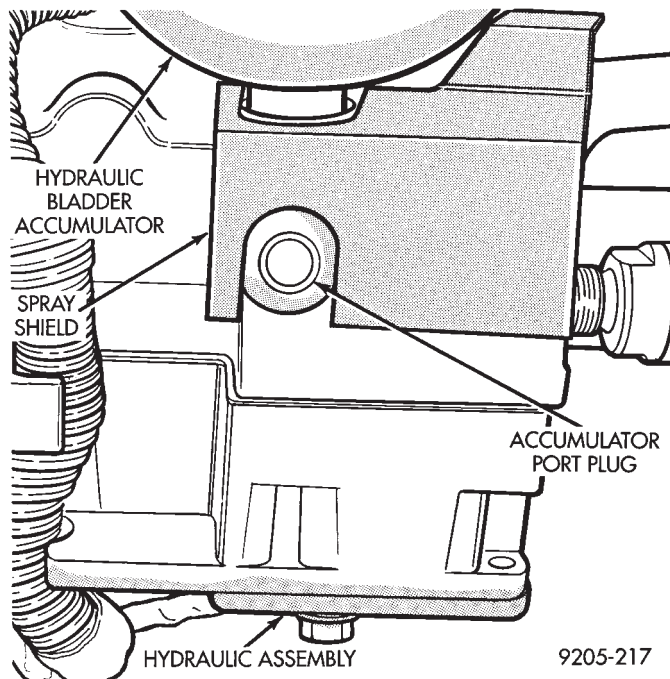

Fig. 1 Hydraulic Assembly Accumulator Port Plug Location

(3) Install pressure gauge to hydraulic assembly adaptor (Fig. 2) into accumulator port of hydraulic assembly, and tighten to 10 N•m (7.5 ft. lbs.) torque.

(4) Install adaptor onto the pressure gauge hose (Fig. 2) and tighten the fitting to 15 N•m (11 ft. lbs.) torque.

(5) Install pressure gauge and hose adaptor assembly onto the adaptor installed in the hydraulic assembly accumulator port. Then install the retaining clip into the groove on the accumulator port adaptor (Fig. 2). **MAKE SURE THAT THE RETAINING CLIP IS INSTALLED ON THE ACCUMULATOR PORT ADAPTOR BEFORE RE-PRESSURIZING THE HYDRAULIC SYSTEM.**

WARNING: BEFORE REMOVING PRESSURE GAUGE AND ADAPTOR, BE SURE TO DE-PRESSURIZE THE HYDRAULIC ASSEMBLY. THEN INSTALL AND TIGHTEN ACCUMULATOR PORT PLUG TO 12 N•m (9 FT. LBS.).

It is not necessary to bleed the hydraulic assembly or brake system after installation and removal of the pressure gauge. Unless additional tubes, hoses, or fittings were removed or loosened.

INTERMITTENT FAULTS

As with almost any electronic system, intermittent faults in the ABS system may be difficult to accurately diagnose.

Most intermittent faults are caused by faulty electrical connections or wiring. When an intermittent fault is encountered, check suspect circuits for:

(1) Poor mating of electrical connector halves, or

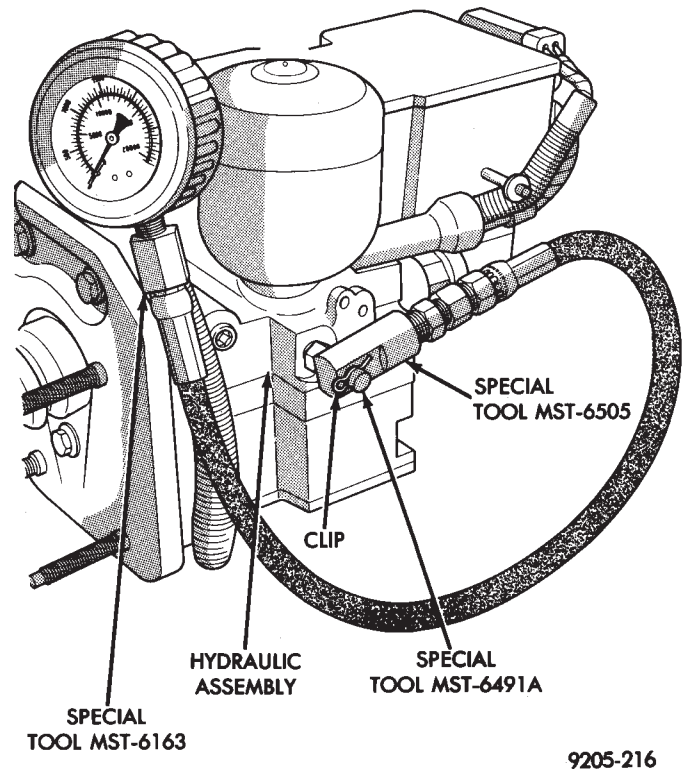

Fig. 2 Pressure Gauge and Adapter Installed on Hydraulic Assembly

electrical terminals not fully seated in the connector body.

(2) Improperly formed or damaged electrical terminals. All connector terminals in a suspect circuit should be carefully reformed to increase contact tension.

(3) Poor terminal to wire connection. This requires removing the terminal from the connector body and inspecting for proper terminal to wire connection.

If a visual check does not find the cause of the problem, operate the vehicle in an attempt to duplicate the condition and record the Fault Code.

Most failures of the ABS system will disable the Anti-Lock function for the entire ignition cycle even if the fault clears before ignition key-off. There are some failure conditions however, which will allow ABS operation to resume during the ignition cycle in which a failure occurred. If the failure conditions are no longer present.

The following conditions may result in intermittent illumination of the Red Brake Warning Lamp and/or Amber Anti-Lock Warning Lamp. All other failures will cause the lamp(s) to remain on until the ignition switch is turned off. Circuits and or components involving these inputs to the (CAB) should be investigated if a complaint of intermittent warning system operation is encountered.

- Low system voltage. If low system voltage is detected by the (CAB), the (CAB) will turn on the Amber Anti-Lock Warning Lamp until normal system voltage is achieved. Once normal voltage is seen at the (CAB), normal operation resumes.
- Low Brake Fluid. A low brake fluid condition will cause the Red Brake Warning Lamp to illuminate. When the fluid sensor again indicates an acceptable fluid level, the Red Brake Warning Lamp will go out. This condition may exist during hard cornering or while the vehicle is on a grade. If the vehicle is in motion above 3 M.P.H. the Amber Anti-Lock Warning Lamp will also be turned on.
- Low Accumulator Pressure. Low Accumulator Pressure will cause both the Red Brake Warning and Amber Anti-Lock Warning Lamps to illuminate. Once normal operating pressure is achieved, the lamps will extinguish and the system will return to normal operation.

Additionally, any condition that results in interruption of power to the (CAB) or hydraulic assembly may cause the Red Brake Warning and Amber Anti-Lock Warning Lamps to illuminate intermittently.

All the conditions (or faults) mentioned above, can store a fault code in the (CAB) module.

ABS SYSTEM DIAGNOSTIC FEATURES

SYSTEM SELF DIAGNOSIS

The ABS system is equipped with a diagnostic capability that may be used to assist in isolation of ABS faults. The features of the diagnostics system are described below.

CONTROLLER ANTI-LOCK BRAKE (CAB)

Fault codes are kept in a Non-Volatile memory until either erased by the technician using the DRB II or erased automatically after 50 ignition cycles (key ON-OFF cycles). The only fault that will not be erased after 50 (KEY CYCLES) is the (CAB) fault. The (CAB) fault can only be erased by using the DRB II. More than one fault can be stored at a time. The number of key cycles since the most recent fault was stored is also displayed. Most functions of the (CAB) and (ABS) system can be accessed by the technician for testing and diagnostic purposes by using the DRB II Diagnostic Tester.

START-UP CYCLE

The START-UP CYCLE takes place immediately after the ignition switch is turned on. It is an electrical check of basic electrical functions such as the System Relay and Anti-Lock Warning Lamp Relay. During this check, the Amber Anti-Lock Warning Lamp is turned on, then turned off at the end of the test. The test takes approximately 1 - 2 seconds to complete.

DRIVE-OFF CYCLE

The DRIVE-OFF CYCLE takes place when the vehicle reaches about 3 miles per hour the first time after an ignition reset. During this test, the modulator solenoid valves are activated briefly to test their function. The DRIVE-OFF CYCLE will be bypassed if you drive-off with the service brake pedal depressed.

LATCHING VERSUS NON-LATCHING FAULTS

Some faults detected by the (CAB) are latching. The fault is latched and (ABS) function is disabled until the ignition switch is reset (turned OFF/ON). Thus (ABS) function is disabled even if the original fault has disappeared during the ignition cycle in which it occurred. Other faults are non-latching; any warning lights that are turned on are only on as long as the fault condition exists. As soon as the condition goes away. The Amber Anti-Lock Warning Light is turned off. Although a fault code will be set in most cases. (Example: low accumulator fault will not be stored for a time of 2 minutes after the fault is detected).

BENDIX ABS SYSTEMS DIAGNOSTICS

The Bendix Anti-Lock 10 Brake System diagnostics. Beyond the basic mechanical diagnostics, systems and components covered earlier in this section, is accomplished by using the DRB II diagnostic tester. See testing procedures outlined in the Bendix Anti-Lock 10 Diagnostics Manual for the 1992 M.Y.

Please reference the above mentioned manual. For any further diagnostic service procedures that are required on the Bendix Anti-Lock 10 Brake System, requiring the use of the DRB II diagnostic tester.

ON CAR HYDRAULIC ABS COMPONENT SERVICE

WARNING: FAILURE TO FULLY DE-PRESSURIZE THE HYDRAULIC ACCUMULATOR BEFORE PERFORMING HYDRAULIC SYSTEM SERVICE OPERATIONS. COULD RESULT IN INJURY TO SERVICE PERSONNEL AND OR DAMAGE TO PAINTED SURFACES. SEE SECTION 2 FOR ADDITIONAL WARNINGS AND CAUTIONS.

GENERAL SERVICE PRECAUTIONS

The following are general precautions that should be observed when servicing the Anti-Lock Brake System and/or other vehicle systems. Failure to observe these precautions may result in Anti-Lock brake system damage.

If welding work is to be performed on the vehicle, using an electric arc welder, the (CAB) connector should be disconnected during the welding operation.

The (CAB) or hydraulic assembly connector should never be connected or disconnected with the ignition switch in the **ON** position.

Many components of the Anti-Lock brake system are not serviceable and must be replaced as an assembly. **Do not attempt to disassemble any component that is not designed to be a serviced component.**

DE-PRESSURIZING HYDRAULIC ACCUMULATOR

The pump/motor assembly will keep the hydraulic accumulator charged to approximately 11,032 and 13,790 kPa (1600 and 2000 psi) any time that the ignition is in the ON position. The pump/motor assembly cannot run if the ignition is off or if either battery cable is disconnected.

Unless otherwise specified, the hydraulic accumulator should be de-pressurized before disassembling any portion of the hydraulic system. The following procedure should be used to relieve the pressure in the hydraulic accumulator:

(1) With ignition off, or either battery cable disconnected, pump the brake pedal a minimum of 40 times, using approximately 222 N (50 lbs.) pedal force. A noticeable change in pedal feel will occur, when the accumulator is discharged.

(2) When a definite increase in pedal effort is felt, pump pedal a few additional times. This will insure removal of all hydraulic pressure from the brake system.

CHECKING BRAKE FLUID LEVEL

CAUTION: Use only brake fluid conforming to DOT 3 specifications such as Mopar® or Equivalent. Do not use any fluid in the brake hydraulic system, which contains a petroleum base. Do not use a container which has been used for petroleum based fluids or a container that is wet with water. Petroleum based fluids will cause swelling and distortion of rubber parts in the hydraulic brake system and water will mix with brake fluid, lowering the fluid boiling point. Keep all brake fluid containers tightly capped to prevent contamination.

The hydraulic assembly is equipped with a plastic fluid reservoir, with a filter/strainer located in the filler neck of each reservoir section.

The Anti-Lock brake system requires that the hydraulic accumulator be de-pressurized when checking the fluid level. To check the brake fluid level, the following procedure should be used:

(1) With the ignition off, de-pressurize the hydraulic accumulator by applying the brake pedal approximately 40 times, using a pedal force of approximately 220 N (50 lbs.). A noticeable change in pedal feel will occur when the accumulator is de-pressurized. When a definite increase in pedal effort is felt, pump pedal a

few additional times. This will insure removal of all hydraulic pressure from the brake system.

(2) Thoroughly clean both reservoir caps and surrounding area of reservoir before cap removal. This will avoid getting dirt into the reservoir and brake fluid.

(3) Inspect the fluid level, see instructions on top of reservoir (Fill To Top Of The White Screen In Front Filter/Strainer).

(4) Fill reservoir to top of white screen on filter/strainer (Fig. 1) as required. Use only brake fluid conforming to DOT 3 specifications such as Mopar® or an Equivalent.

(5) Replace reservoir cap.

BLEEDING BRAKE SYSTEM

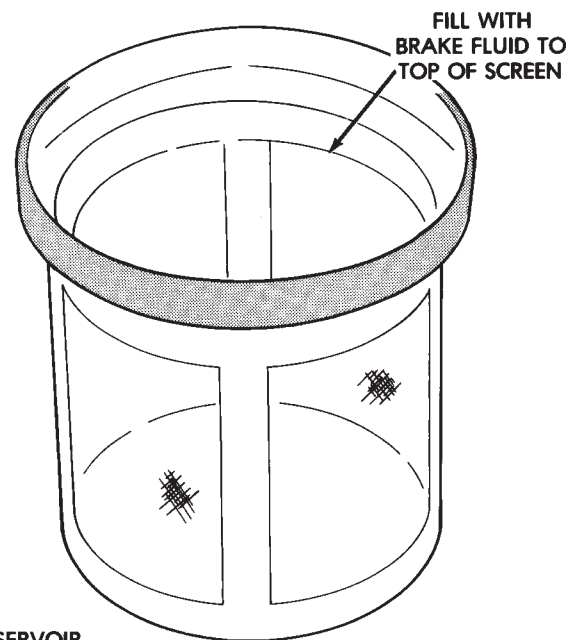

ABS RESERVOIR
FILTER/STRAINER

9205-203

Fig. 1 ABS Fill Level On Filter/Strainer

The Anti-Lock brake system must be bled anytime air is permitted to enter the brake hydraulic system, due to disconnection of brake lines or hoses for service. It is important to note that excessive air in the brake system may set a primary pressure/delta P fault in the (CAB). Refer to Diagnosis, for further information.

Pressure bleeding or manual bleeding procedures can be used when bleeding the (ABS) hydraulic system, after brake lines or hoses have been disconnected. Bleeding the (ABS) hydraulic system is also necessary after the replacement of the hydraulic assembly or wheel brakes.

During bleeding operations, be sure that the brake fluid level remains close to the FULL level in the reservoir. Check the fluid level periodically during

the bleeding procedure and add only DOT 3 brake fluid to the reservoir as required.

PRESSURE BLEEDING (FIG. 2)

The brake lines may be pressure bled, using a standard diaphragm type pressure bleeder. Only diaphragm type pressure bleeding equipment should be used to prevent air, moisture, and other contaminants from entering the system. The following procedure should be used for pressure bleeding of the master cylinder and wheel circuits (Fig. 2)

(1) Ignition should be turned off and remain off throughout this procedure.

(2) De-pressurize the hydraulic accumulator by pumping the brake pedal a minimum of 40 times, as fully described in this section under De-Pressurizing Hydraulic Accumulator.

WARNING: FAILURE TO DE-PRESSURIZE HYDRAULIC ACCUMULATOR, BEFORE PERFORMING THIS OPERATION, MAY RESULT IN PERSONAL INJURY AND/OR DAMAGE TO PAINTED SURFACES.

(3) Remove both reservoir caps (Fig. 2).

(4) Install pressure bleeder adapter, on front reservoir port and a cap on the rear port of the reservoir (Fig. 2)

(5) Attach bleeding equipment to bleeder adapter (Fig. 2). Charge pressure bleeder to approximately 138 kPa (20 psi).

(6) Connect a transparent hose to the caliper bleed

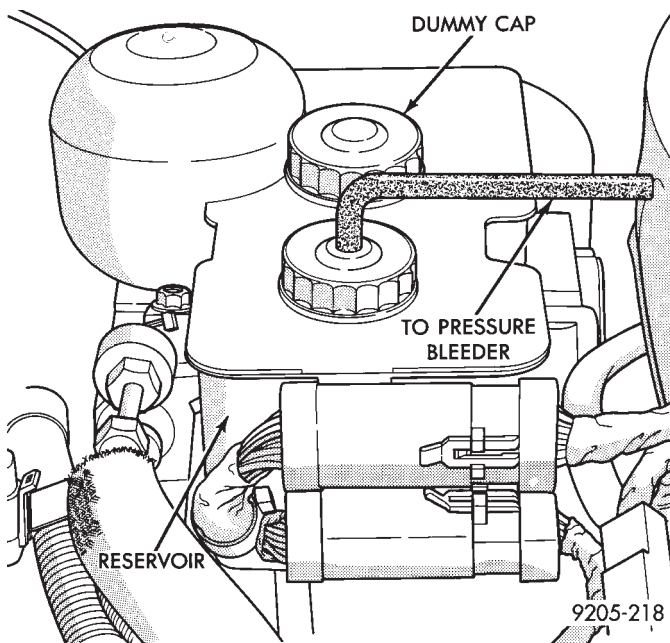

Fig. 2 Pressure Bleeding Brake System

screw (Fig. 3). Submerge the free end of the hose in a clear glass container, which is partially filled with clean, fresh brake fluid.

(7) With the pressure bleeder turned on, open the caliper bleed screw 3/4 to one full turn allowing brake fluid to flow into the container. Leave bleed screw open until a clear, bubble-free flow of brake fluid is coming from the hose in the container. If the reservoir has been drained or the hydraulic assembly removed from the car before the bleeding operation. Slowly pump the brake pedal one or two times while the bleed screw is open and fluid is flowing. This will help purge any trapped air from the hydraulic assembly. Tighten bleeder screw to 10 N•m (7.5 ft. lbs.) torque.

(8) Step 7 above should be done at all wheel brakes, following the order wheel by wheel as listed below.

- a) Left rear.
- b) Right rear.
- c) Left front.
- d) Right front.

(9) After bleeding is completed at all four wheel brakes. Remove the pressure bleeding equipment and bleeder adapter by closing the pressure bleeder valve and slowly unscrewing the bleeder adapter from the hydraulic assembly reservoir. **Failure to release pressure in the reservoir will cause spillage of brake fluid, and could result in personal injury or damage to painted surfaces.**

(10) Using a syringe or equivalent method, remove excess fluid from the reservoir to bring the brake fluid to the required fill level (Fig. 1). If brake fluid is below the proper level add Mopar® brake fluid or equivalent conforming to DOT 3, requirements.

(11) Install the reservoir caps and turn on the ignition to allow the (ABS) pump to charge the accumulator.

MANUAL BLEEDING

Brake lines can be bled, using the manual bleeding method. Manual bleeding is a two person operation, one to pump the brake pedal and the other to bleed each wheel brake. The following procedure should be used:

De-pressurizing the hydraulic accumulator is done by following the steps described below.

(1) Verify that the ignition switch is in the off position.

(2) De-pressurize the hydraulic accumulator by pumping the brake pedal a minimum of 40 times. Use the procedure as described in De-Pressurizing Hydraulic Accumulator listed earlier in this section.

WARNING: FAILURE TO DE-PRESSURIZE HYDRAULIC ACCUMULATOR, PRIOR TO PERFORMING THIS OPERATION, MAY RESULT IN PERSONAL INJURY AND/OR DAMAGE TO PAINTED SURFACES.

(3) Connect a transparent hose to the bleed screw on the wheel cylinder or brake caliper that is to be

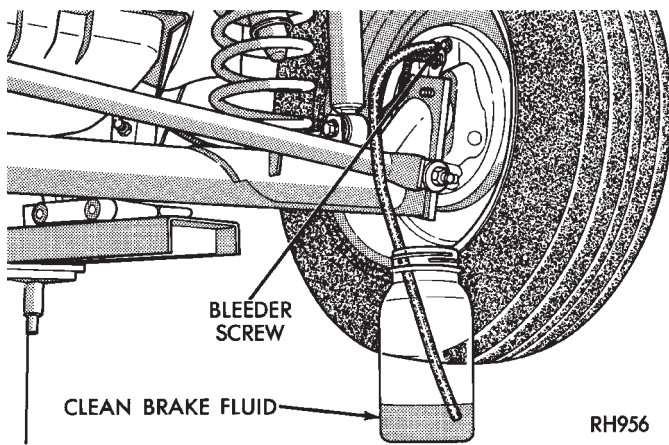

Fig. 3 Bleeding Brake System

bled (Fig. 3). Submerge the free end of the hose in a clear glass container, which is partially filled with clean, fresh brake fluid.

(4) Slowly pump the brake pedal several times, using full strokes of the pedal and allowing approximately five seconds between pedal strokes. After two or three strokes, continue to hold pressure on the pedal, keeping it at the bottom of its travel.

(5) With pressure on the pedal, open the bleed screw 3/4 to 1 full turn. Leave bleed screw open until fluid no longer flows from the hose. Tighten the bleed screw and release the pedal. **Be sure that the bleed screw is tightened before brake pedal is released, or air may be drawn back into hydraulic system.**

(6) Repeat Steps 3, 4 and 5 on each wheel brake, until clear, bubble-free fluid flows from the hose.

(7) Repeat the above sequence at each wheel brake, in the following order:

- a) Left rear.
- b) Right rear.
- c) Left front.
- d) Right front.

(8) Fill the hydraulic assembly to the proper fill level (Fig. 1) using Mopar® or equivalent brake fluid meeting DOT 3, requirements.

(9) Install both reservoir caps on reservoir.

(10) Turn the ignition switch to the RUN position to allow the Pump/Motor to turn on and recharge the accumulator.

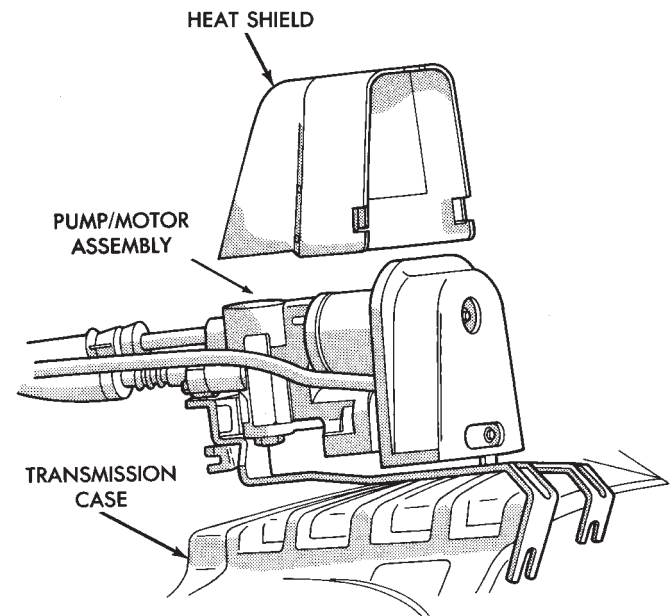

Fig. 4 Pump/Motor Assembly Mounting

PUMP/MOTOR SERVICE (FIG. 4)

REMOVE

(1) De-pressurize the hydraulic accumulator by pumping the brake pedal a minimum of 40 times. Using the procedure as described in De-Pressurizing Hydraulic Accumulator listed earlier in this section.

WARNING: FAILURE TO DE-PRESSURIZE HYDRAULIC ACCUMULATOR, BEFORE PERFORMING THIS OPERATION, MAY RESULT IN PERSONAL INJURY AND/OR DAMAGE TO PAINTED SURFACES.

(2) Remove the fresh air intake ducts from the engine induction system.

(3) Loosen the low pressure hose clamp (Fig. 5) at the hydraulic assembly.

(4) Disconnect the high pressure fluid line routing clip from the battery tray (Fig. 5).

(5) Disconnect electrical connectors (including the pump/motor) that runs across the engine compartment, in the vicinity of the pump/motor assembly high and low pressure hoses.

(6) Loosen the high pressure hose tube nut at the hydraulic assembly fitting (Fig. 5).

(7) Remove the high and low pressure hose assembly (Fig. 5) from the hydraulic assembly. Cap all open ports on reservoir and hydraulic assembly to prevent brake fluid from leaking out.

(8) Disconnect the pump/motor electrical connector (Fig. 5) from the engine mount.

(9) Remove the pump/motor assembly heat shield bolt, from front of pump bracket.

(10) Remove front heat shield.

(11) Lift pump/motor assembly from bracket and remove assembly from the vehicle.

INSTALL

(1) Install pump/motor assembly in reverse order of removal.

(2) Tighten the pump/motor assembly fluid lines to the torque values shown below.

- Low pressure hose clamp. 1 N•m (10 in. lbs.)
- High pressure hose fitting to pump/motor assembly. 16 N•m (145 in. lbs.) Fig. 5.

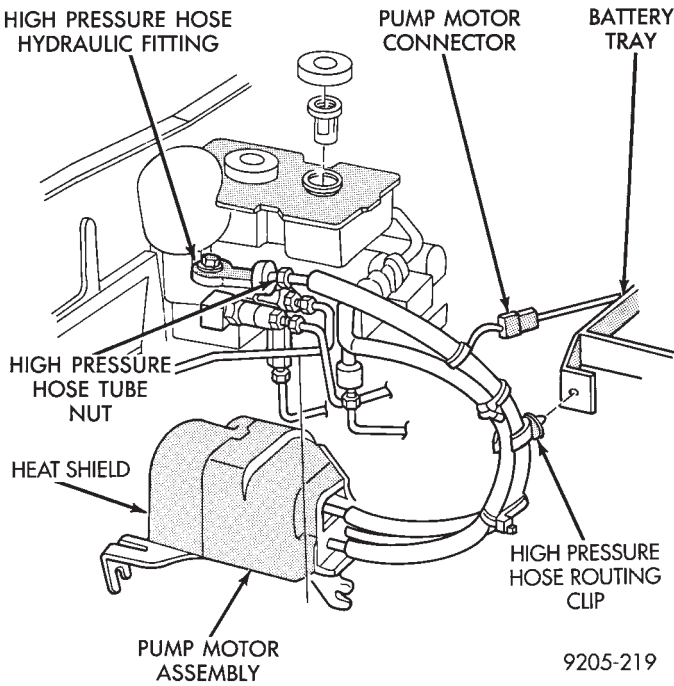

Fig. 5 Brake Tube and Hose Routing

CAUTION: Be sure the high pressure hose routing clip, is securely fastened to the battery tray and hose, when hose is reinstalled (See Fig. 5).

BRAKE FLUID PRESSURE AND RETURN HOSES (FIG. 6)

REMOVE

(1) Remove the pump/motor assembly from its mounting bracket, see Pump/Motor Service.

(2) Cut the 4 tie straps that secure the high and low pressure hoses and pump/motor assembly wiring harness together Fig. 6.

(3) Remove the banjo bolt and spray shield from the pump/motor assembly Fig. 6.

(4) Remove the high and low pressure hose assembly from the pump/motor assembly Fig. 6.

INSTALL

(1) The rubber O-Rings used on the high and low pressure hose connections to the pump/motor assembly. Should be lubricated with clean brake fluid before connecting hoses to pump/motor assembly.

(2) Position high and low pressure hoses and spray shield on the pump/motor assembly (Fig. 6). Then install the banjo bolt and torque to 14 N•m (120 in.lbs.)

(3) Carefully route wiring harness along the side of the high and low pressure hose assembly Fig. 6.

(4) Install the 4 tie straps around the hose assembly and wiring harness per the sequence and locations shown in (Fig. 6).

(5) Install the pump/motor assembly back on mounting bracket, See Pump/Motor Service.

(6) Turn the ignition switch to the RUN position. This will turn on the pump/motor assembly to charge the high pressure system.

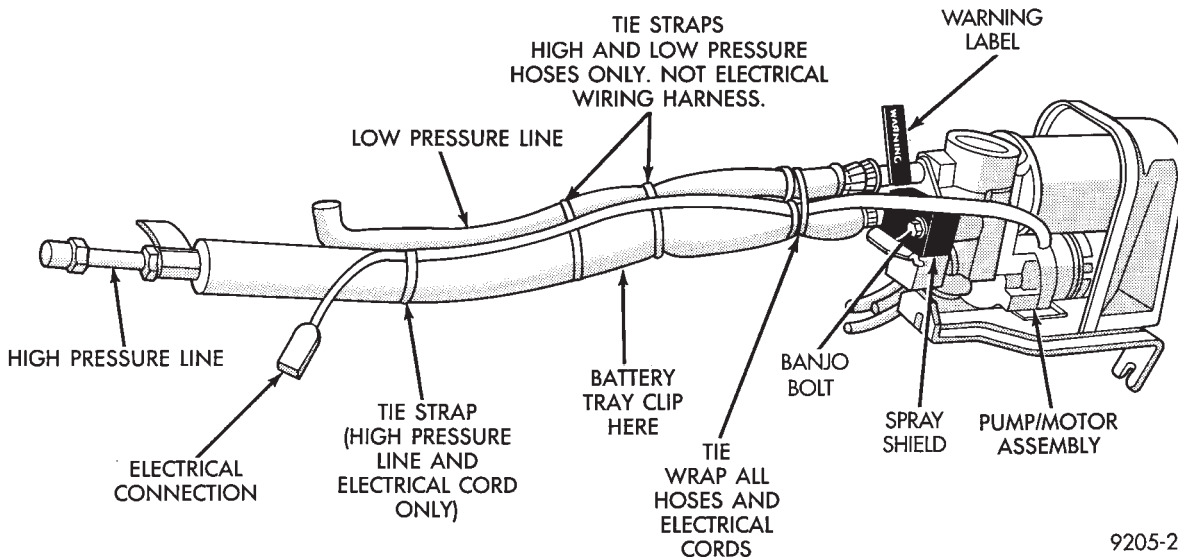

Fig. 6 Positioning Tie Straps

(7) Pump the brake system down as detailed in De-pressurizing Hydraulic Accumulator in this section of the service manual.

(8) Fill the hydraulic assembly to the proper level with Mopar® brake fluid or an equivalent meeting DOT 3 specifications. See Master Cylinder Fluid Level in the Service Adjustments section of this group.

HYDRAULIC ASSEMBLY

REMOVE

(1) De-pressurize the hydraulic accumulator by pumping the brake pedal a minimum of 40 times. Using the procedure as described in De-Pressurizing Hydraulic Accumulator listed earlier in this section.

WARNING: FAILURE TO DE-PRESSURIZE HYDRAULIC ACCUMULATOR, BEFORE PERFORMING THIS OPERATION, MAY RESULT IN PERSONAL INJURY AND/OR DAMAGE TO PAINTED SURFACES.

(2) Remove fresh air intake duct and air cleaner from vehicle.

(3) Remove the windshield washer fluid bottle from the vehicle.

(4) Disconnect all electrical connectors from the hydraulic assembly.

(5) Remove as much fluid as possible from the reservoir on the hydraulic assembly.

(6) Remove pump high pressure hose fitting (Fig. 7) from hydraulic assembly.

(7) Disconnect pump return hose from steel tube. Cap the end of the steel tube.

(8) Disconnect the 4 brake tubes from the hydraulic assembly (Fig. 7).

(9) From under the instrument panel, position a small screwdriver between the center tang on the retainer clip and the pin in the brake pedal. Rotate the screwdriver enough to allow the retainer clip center tang to pass over the end of the brake pedal pin. **Discard the old retainer clip, a new clip must be used when hydraulic assembly is reinstalled (Fig. 8).**

(9) Remove the 4 hydraulic assembly to dash panel mounting nuts from the hydraulic assembly mounting studs, located under instrument panel (Fig. 8).

(10) Remove hydraulic assembly from vehicle.

INSTALL

(1) Position the hydraulic assembly into its mounting holes on the dash panel of the vehicle.

(2) Install and tighten the 4 hydraulic assembly to dash panel mounting stud nuts (Fig. 8) to 28 N•m (250 in. lbs.) torque.

(3) Using lubriplate or equivalent, coat the bearing surface of the brake pedal pin.

(4) Connect push rod to pedal pin and install a **NEW** retainer clip. **HYDRAULIC ASSEMBLY PUSH ROD**

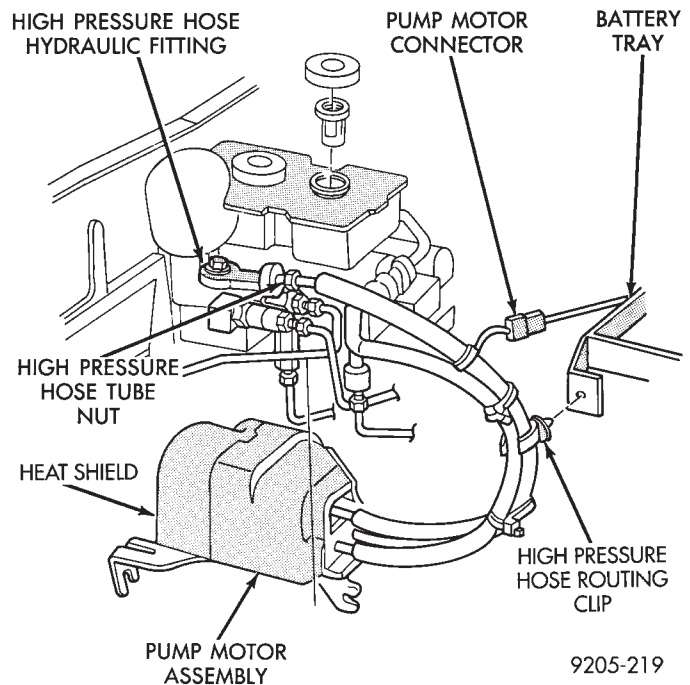

Fig. 7 Brake Tube and Hose Routing at Hydraulic Unit

MUST BE ASSEMBLED TO BRAKE PEDAL PIN IN THE POSITION AS SHOWN IN (FIG. 8).

(5) Install all 4 brake tubes on the hydraulic assembly (Fig. 7) and torque tube fittings to their specified values (See Torque Specifications). If proportioning valves were removed from the hydraulic assembly, install and tighten to 40 N•m (30 ft. lbs.) torque.

(6) Install return hose on steel tube. Tighten the return hose clamp to 1 N•m (10 in.lbs.)

(7) Install high pressure hose to hydraulic assembly (Fig. 7). Tighten the hose, to hydraulic assembly fitting to 16 N•m (145 in. lbs)

(8) Fill hydraulic assembly brake fluid reservoir to top of screen on the reservoir filter/strainer (Fig. 9).

(9) Connect all electrical connectors to the hydraulic assembly.

(10) Bleed the entire brake system, see Bleeding Brake System in this section of the Service Manual.

(11) Replace all fresh air intake ducts, air cleaner and washer bottle.

(12) Check that the brake fluid in the hydraulic assembly is at the correct level before moving vehicle. (See Checking Brake Fluid Level in this section of the service manual).

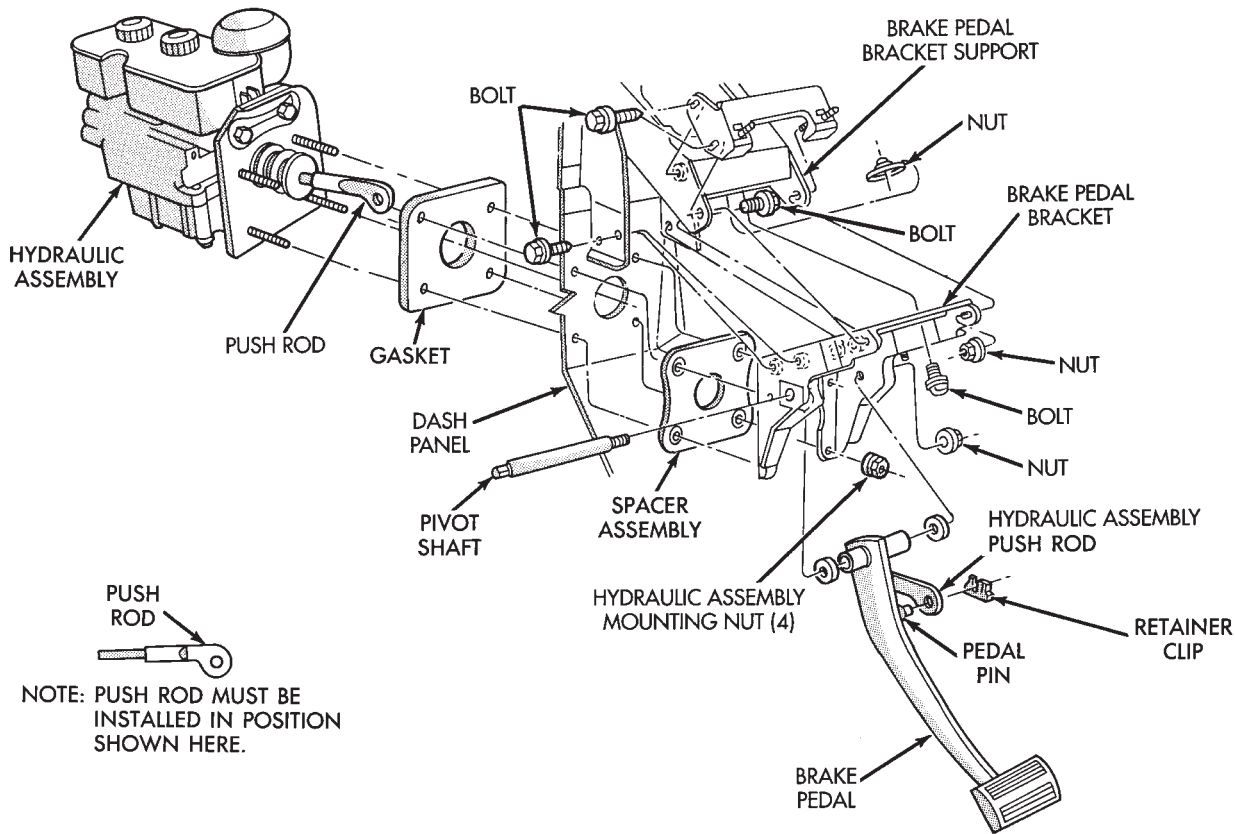

9205-221

Fig. 8 Removing or Installing Hydraulic Assembly

Using the procedure as described in De-Pressurizing Hydraulic Accumulator listed earlier in this section.

WARNING: FAILURE TO DE-PRESSURIZE HYDRAULIC ACCUMULATOR, BEFORE PERFORMING THIS OPERATION, MAY RESULT IN PERSONAL INJURY AND/OR DAMAGE TO PAINTED SURFACES.

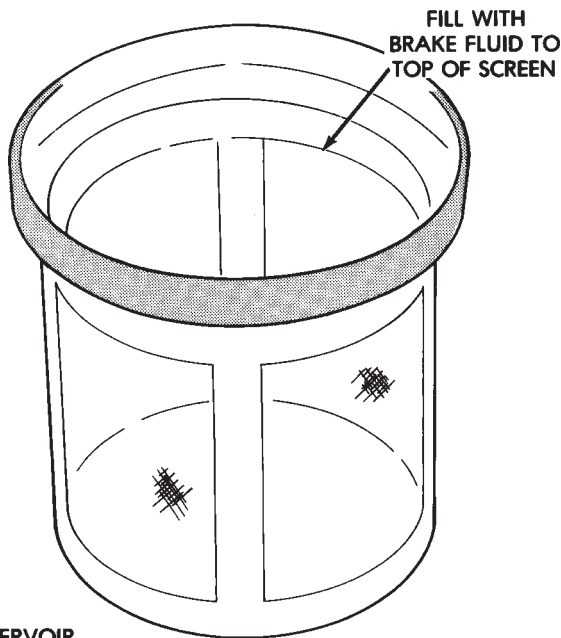

ABS RESERVOIR
FILTER/STRAINER

9205-203

Fig. 9 ABS Fill Level On Filter/Strainer
BRAKE FLUID RESERVOIR

REMOVE

(1) De-pressurize the hydraulic accumulator by pumping the brake pedal a minimum of 40 times.

(2) Remove as much brake fluid as possible from the fluid reservoir, using a syringe or equivalent method.

(3) Using Oil Filter Band Wrench, Special Tool C-4065 or equivalent loosen bladder accumulator. Then remove the bladder accumulator and brake fluid spray shield from the hydraulic assembly (Fig. 10). Remove high pressure banjo fitting from hydraulic assembly.

(4) Using needle nose pliers, remove the three fluid reservoir retaining pins from the hydraulic assembly (Fig. 11). Compress the barb on the opposite side of retaining pin to prevent pin from breaking.

(5) Remove reservoir from hydraulic assembly by CAREFULLY prying between reservoir and hydraulic assembly with a blunt prying tool (Fig. 12). Use a rocking motion to help disengage reservoir from grommets while prying. **BE EXTREMELY CAREFUL TO AVOID DAMAGING OR PUNCTURING RESERVOIR DURING THIS PROCEDURE.**

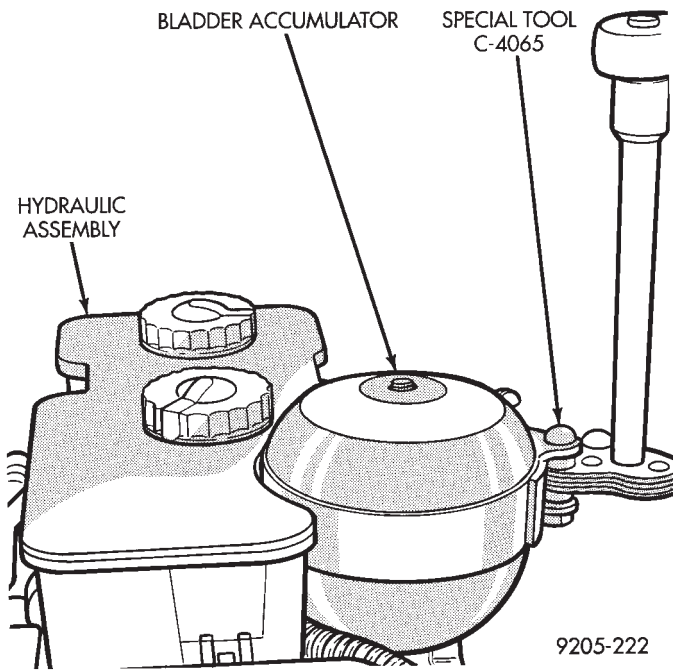

Fig. 10 Removing Bladder Accumulator

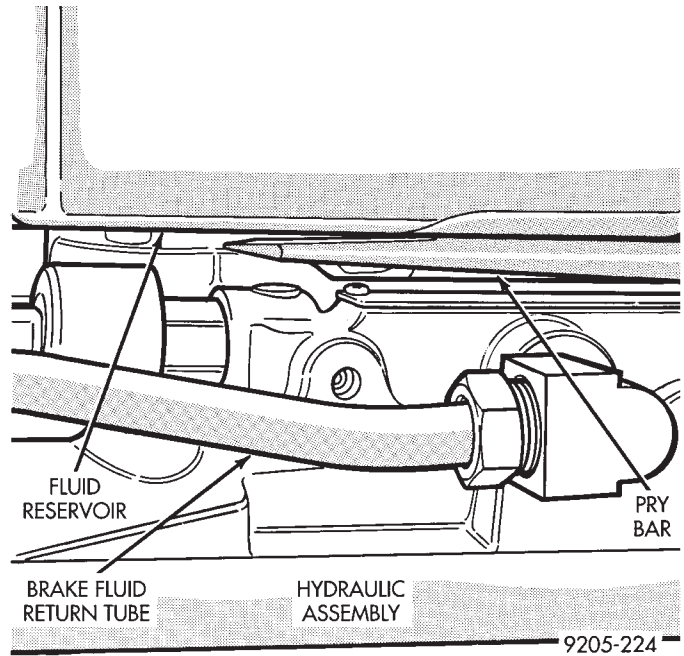

Fig. 12 Remove Reservoir From Hydraulic Assembly

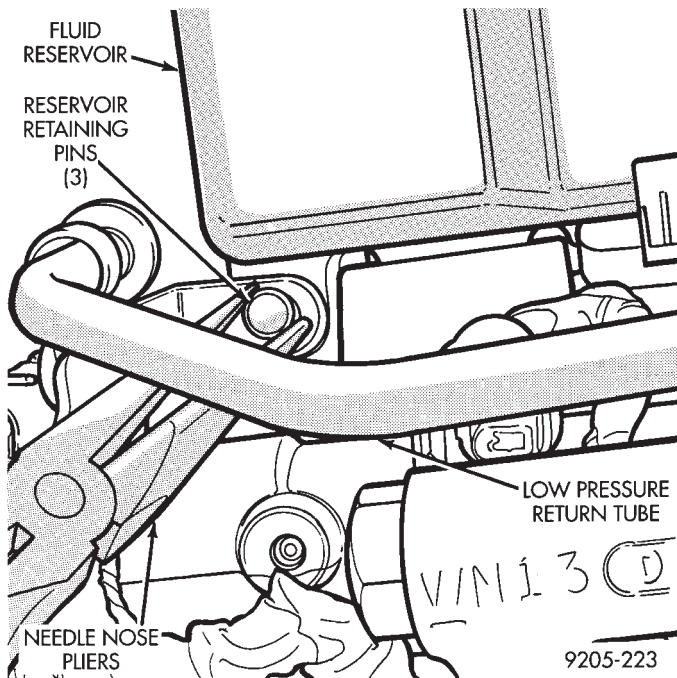

Fig. 11 Remove Reservoir Retaining Pins

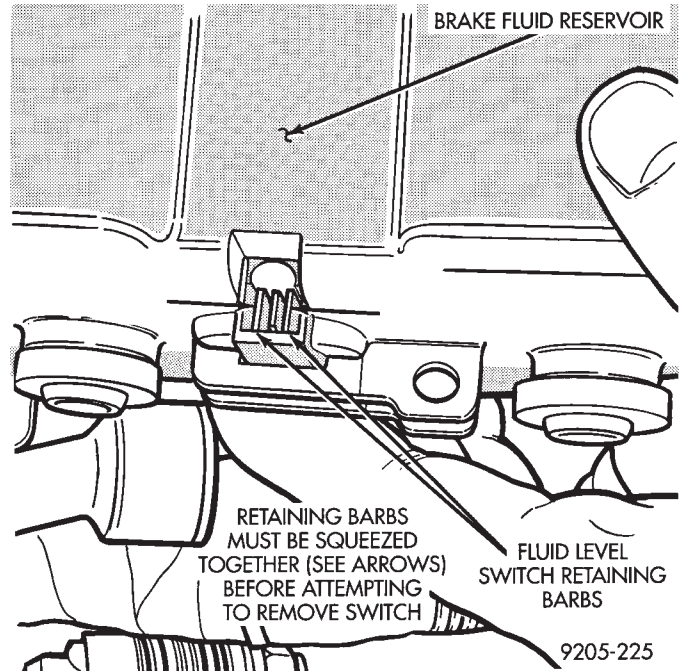

Fig. 13 Fluid Switch Retaining Barbs

(6) Remove the brake fluid level sensor switch from the reservoir.

Remove switch by compressing the retaining barbs (Fig. 13) on the end of the switch and then slide switch out of the brake fluid reservoir (Fig. 14)

(7) Using fingers, remove the 3 reservoir grommets (Fig. 14) from the hydraulic assembly or reservoir, and discard. **Grommets must not be reused when reservoir is installed on hydraulic assembly.**

INSTALL

(1) Thoroughly lubricate the new reservoir grommets with clean brake fluid and install on reservoir outlet ports (Fig. 14). **The new reservoir grommets supplied with reservoir, must ALWAYS be used.**

(2) Install brake fluid level switch into brake fluid reservoir (FIG. 14).

(3) Press reservoir into hydraulic assembly **BY HAND**, using a rocking motion to help seat reservoir into hydraulic assembly. Be sure that grommets are fully seated in the hydraulic assembly. **DO NOT AT-**

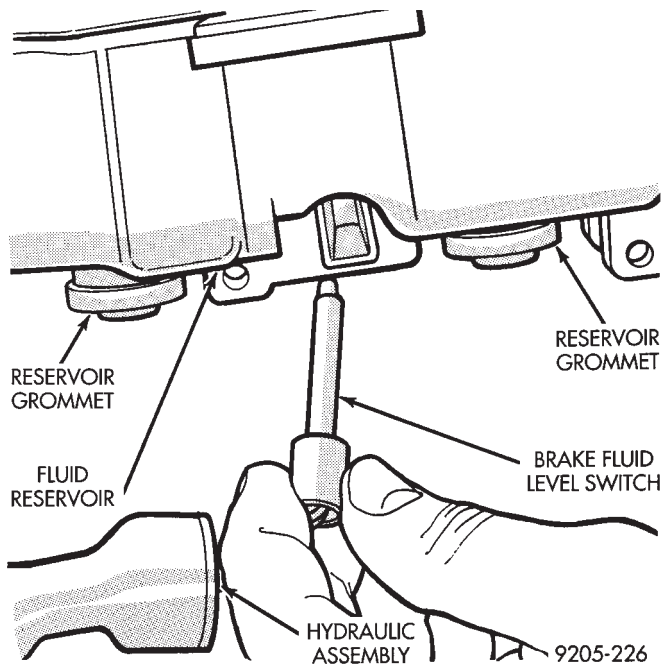

Fig. 14 Remove Brake Fluid Level Switch

TEMPT TO POUND RESERVOIR INTO HYDRAULIC ASSEMBLY, USING A HAMMER.

(4) Using needle nose pliers, install the 3 brake fluid reservoir to hydraulic assembly retaining pins (Fig. 11). Make sure that pins are fully installed with barbs extending past reservoir on opposite side.

(5) Reinstall the high pressure hose, banjo fitting onto the hydraulic assembly and torque the fitting to 13 N•m (10.0 ft.lbs).

(6) Install the brake fluid spray shield and bladder accumulator onto the hydraulic assembly. Install the bladder accumulator by hand to be sure it does not bet cross threaded. **Be sure that the O-Ring on the bladder accumulator is fully seated into the hydraulic assembly.**

(7) Using Oil Filter Band Wrench, Special Tool C-4065 or equivalent, (Fig. 10) torque the bladder accumulator to 48 N•m (35 ft. lbs.)

(8) Fill the hydraulic assembly reservoir to the top of the screen on the filter/strainer (Fig. 15). Using fresh clean brake fluid such as Mopar® or equivalent, conforming to DOT 3 requirements.

HYDRAULIC BLADDER ACCUMULATOR

REMOVE

(1) De-pressurize the hydraulic accumulator by pumping the brake pedal a minimum of 40 times. Using the procedure as described in De-Pressurizing Hydraulic Accumulator listed earlier in this section.

WARNING: FAILURE TO DE-PRESSURIZE THE HYDRAULIC ASSEMBLY/ACCUMULATOR BEFORE PERFORMING THIS OPERATION, MAY RESULT IN

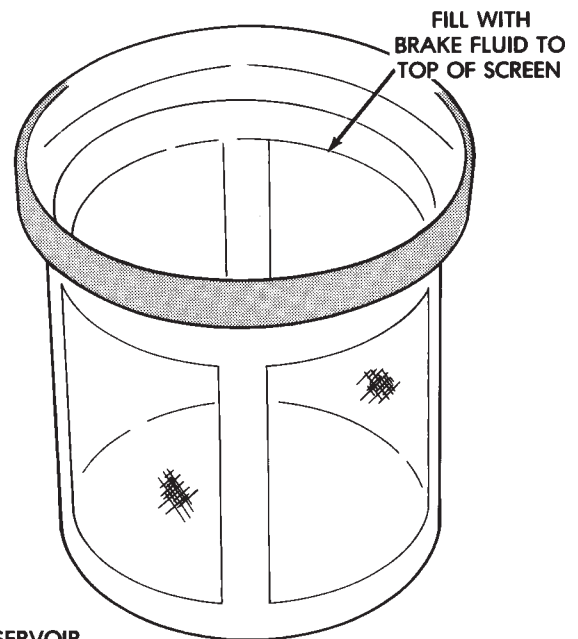

**ABS RESERVOIR
FILTER/STRAINER**

9205-203

Fig. 15 ABS Reservoir Fill Level On Filter/Strainer

PERSONAL INJURY AND/OR DAMAGE TO PAINTED SURFACES OF THE VEHICLE.

(2) Using Oil Filter Band Wrench, Special Tool C-4065 or equivalent loosen bladder accumulator. Then remove the bladder accumulator and brake fluid shield from the hydraulic assembly (Fig. 16).

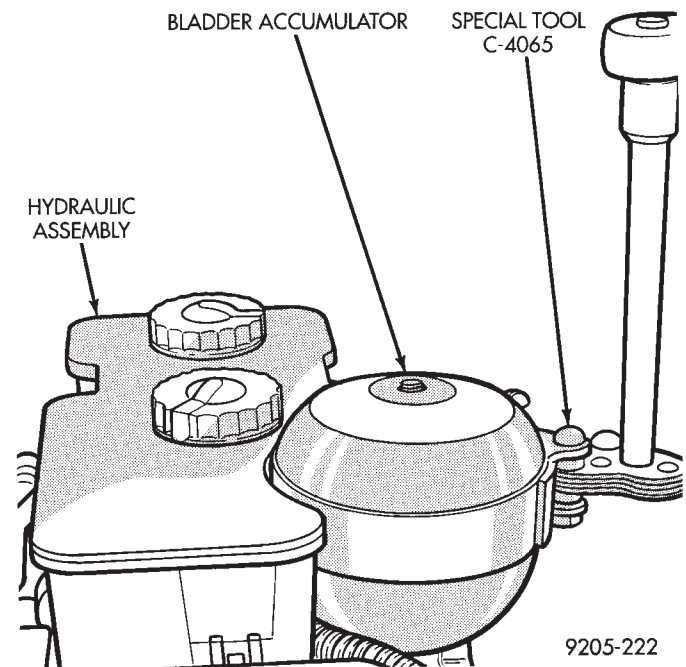

Fig. 16 Remove And Install Bladder Accumulator

INSTALL

(1) Install the brake fluid spray shield onto the hydraulic accumulator (Fig. 1).

(2) Install the bladder accumulator onto the hy-

draulic assembly by hand. Be sure that the O-Ring on the bladder accumulator is fully seated into the hydraulic assembly.

(3) Using Oil Filter Band Wrench, Special Tool C-4065 or equivalent, (Fig. 16) torque the bladder accumulator to 48 N•m (35 ft. lbs.)

(4) Turn ignition switch to the run position to energize the pump/motor assembly and pressurize hydraulic system. Check for leakage at the hydraulic assembly to hydraulic bladder accumulator fitting.

(5) Again de-pressurize the accumulator by pumping the brake pedal a minimum of 40 times as described in De-Pressurizing Hydraulic Accumulator in this section of the manual.

(6) Then check the brake fluid level in the hydraulic assembly reservoir. If brake fluid level is low, fill reservoir to proper level (Fig. 15) with Mopar® brake fluid or equivalent conforming to DOT 3 requirements.

PROPORTIONING VALVES (FIG. 17)

CAUTION: Proportioning valves should never be disassembled or repaired in any way, repair is by replacement only.

REMOVE

(1) De-pressurize the hydraulic accumulator by pumping the brake pedal a minimum of 40 times.

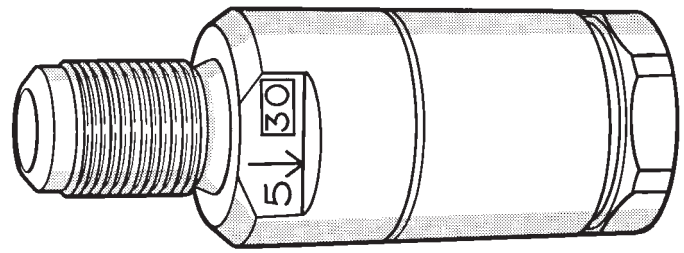

9205-227

Fig. 17 ABS Proportioning Valve

Using the procedure as described in De-Pressurizing Hydraulic Accumulator listed earlier in this section.

WARNING: FAILURE TO DE-PRESSURIZE THE HYDRAULIC ASSEMBLY/ACCUMULATOR PRIOR TO PERFORMING THIS OPERATION, MAY RESULT IN PERSONAL INJURY AND/OR DAMAGE TO PAINTED SURFACES OF THE VEHICLE.

- (2) Remove fresh air intake ducts and air cleaner.
- (3) Remove pressure and return hose (Fig. 5) from hydraulic unit. (See Pressure and Return Hose Section For Proper Removal Procedure).
- (4) Remove brake tube from the proportioning valve that requires servicing.

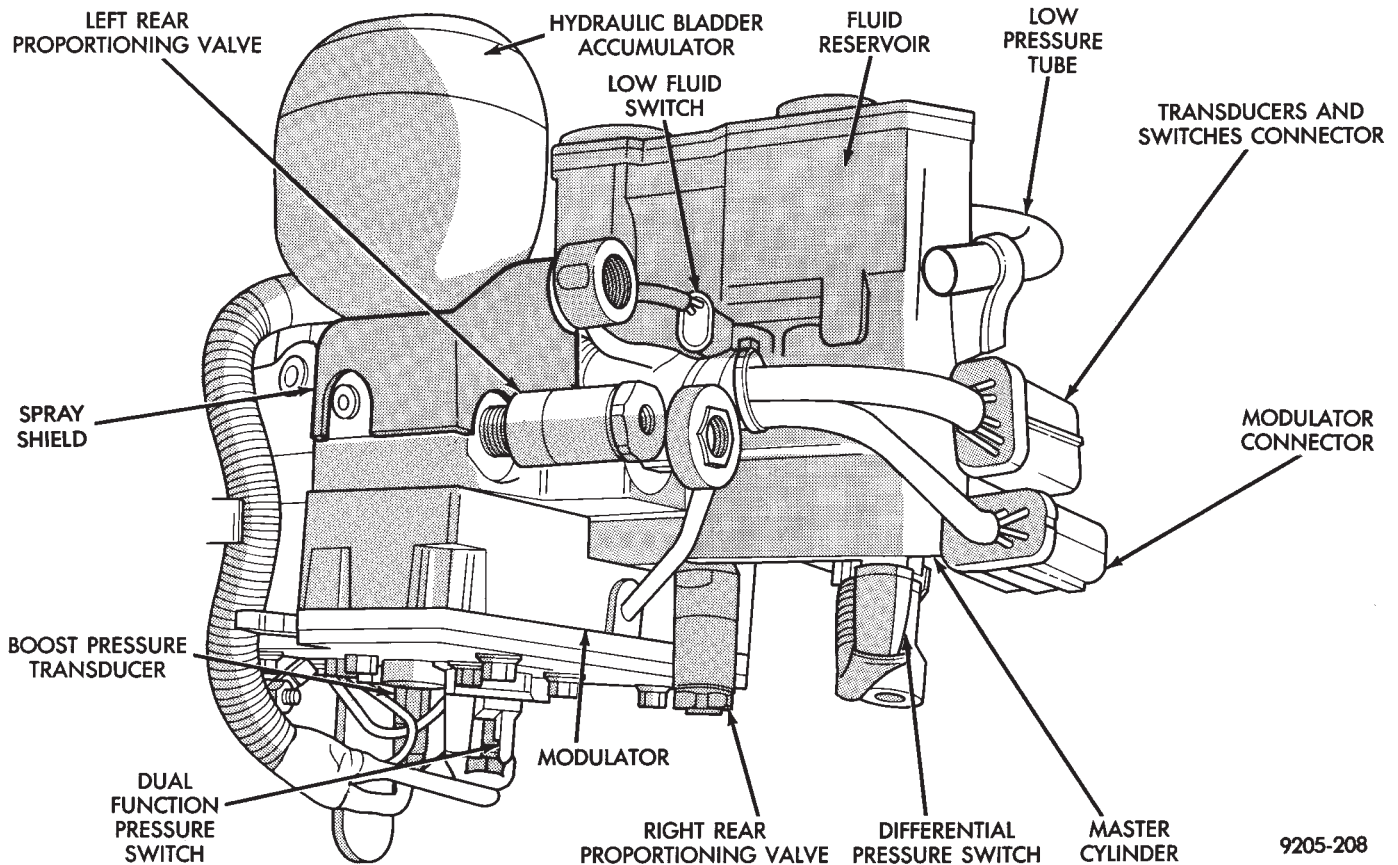

9205-208

Fig. 18 Hydraulic Assembly

(5) Remove proportioning valve requiring service from the hydraulic assembly (Fig. 18).

INSTALL

(1) Install proportioning valve on hydraulic assembly and tighten to 40 N•m (30 ft. lbs.) torque.

(2) Install brake tube on proportioning valve. Tighten tube nut to 16 N•m (145 in. lbs.) torque.

(3) Install hydraulic pressure and return hoses. Torque pressure hose to hydraulic assembly fitting to 16 N•m (145 in. lbs.). Torque return hose to metal tube hose clamp to 1 N•m (10 in. lbs.).

(4) Install fresh air intake duct and air cleaner.

(5) Bleed the affected brake line, see Bleeding Brake System in this section.

ON CAR ELECTRONIC ABS COMPONENT SERVICE

CONTROLLER ANTI-LOCK BRAKE (FIG. 1)

REMOVE

(1) Turn vehicle ignition off.

(2) Remove speed control servo from vehicle. (See Section 8 in the Service Manual for speed control servo, remove/install procedure.)

(3) Disconnect the wiring harness 60 way connector (Fig. 1) from the Controller Anti-Lock Brake Module (CAB). **VERIFY THAT THE VEHICLE IGNITION IS OFF, BEFORE REMOVING THE 60 WAY CONNECTOR.**

(4) Remove the 3 (CAB) module to fender shield mounting bolts (Fig. 1).

(5) Remove the (CAB) module from the vehicle.

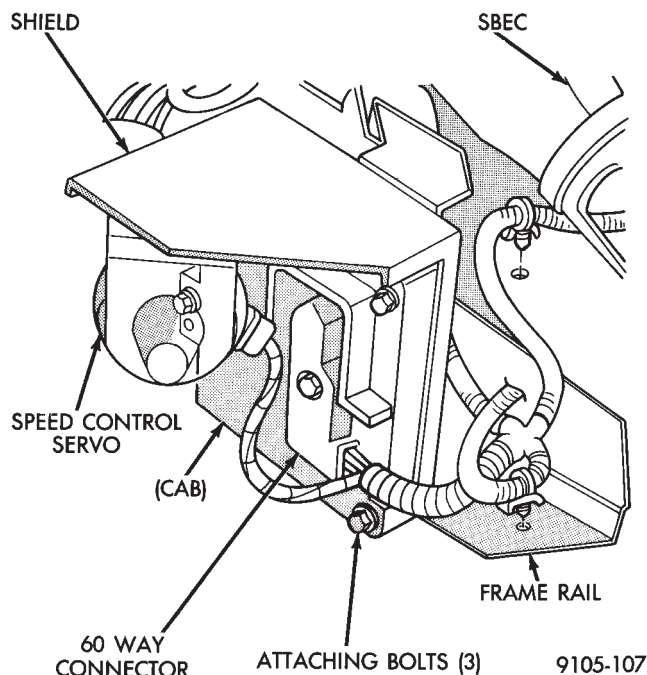

Fig. 1 Location Controller Anti-Lock Brake (CAB)

INSTALL

(1) The Controller Anti-Lock Brake (CAB) module installation is done in the reverse order of removal.

- Tighten the 60 way (CAB) electrical connector retaining bolt to 5 N•m (40 in. lbs.).
- Tighten the (CAB) module to fender shield attaching bolts to 12 N•m (105 in. lbs.).

SYSTEM RELAY, ANTI-LOCK WARNING LAMP RELAY AND PUMP/MOTOR RELAYS (FIG. 2)

REMOVE/INSTALL

The service procedure for removing and installing both the System Relay, Yellow Light Relay and Pump/Motor are the same. Though the System Relay and Yellow Light Relay are a single module, and the Pump/Motor Relay is a separate component.

(1) Disconnect the wiring harness electrical connector from the relay housing (Fig. 2).

(2) Remove the attaching screw holding the relay housing to the fender shield (Fig. 2).

(3) Install the new relay assembly. By inserting the anti-rotation tab on the assembly into its hole in the inner fender. Then secure the relay assembly to the fender shield with its attaching screw.

(4) Install the wiring harness onto the relay assembly. Firmly pushing the connector onto the relay until the locking tabs are fully engaged with the relay.

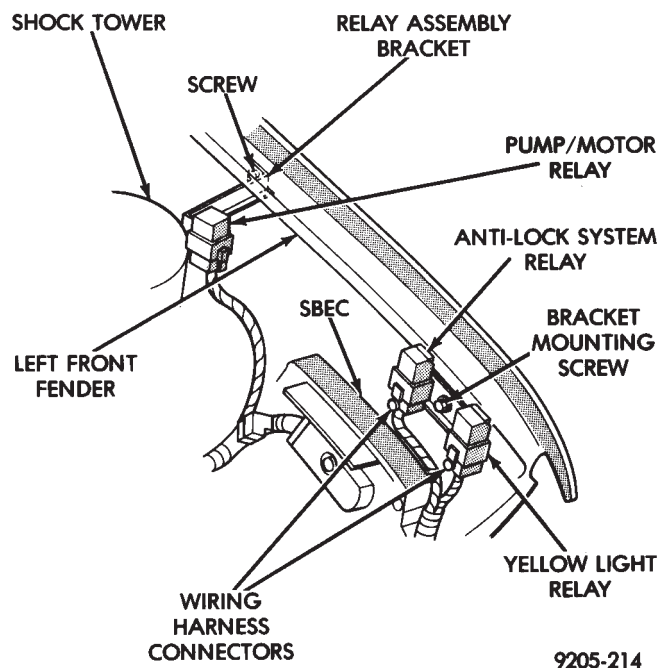

Fig. 2 Pump/Motor and Anti-Lock System Relays

DUAL FUNCTION PRESSURE SWITCH

REMOVE

WARNING: FAILURE TO DE-PRESSURIZE THE HYDRAULIC ASSEMBLY/ACCUMULATOR PRIOR TO PERFORMING THIS OPERATION, MAY RESULT IN PERSONAL INJURY AND/OR DAMAGE TO PAINTED SURFACES OF THE VEHICLE.

CAUTION: THOROUGHLY CLEAN THE BOTTOM OF THE HYDRAULIC ASSEMBLY IN THE AREA OF THE DUAL FUNCTION PRESSURE SWITCH, BEFORE REMOVING THE SWITCH FROM HYDRAULIC ASSEMBLY. USE MOPAR BRAKE PARTS CLEANER OR AN EQUIVALENT. EXTREME CARE MUST BE USED SO NO DIRT IS ALLOWED TO ENTER THE HYDRAULIC ASSEMBLY THROUGH WHERE THE DUAL FUNCTION PRESSURE SWITCH IS MOUNTED. ANY DIRT ENTERING HYDRAULIC ASSEMBLY MAY PLUG INTERNAL PASSAGES CAUSING A HYDRAULIC ASSEMBLY FAILURE.

(1) De-pressurize the hydraulic accumulator by pumping the brake pedal a minimum of 40 times. Using the procedure as described in De-Pressurizing Hydraulic Accumulator listed earlier in this section.

(2) Raise vehicle See Hoisting, Group 0.

(3) From under vehicle, disconnect the wiring harness connectors from the dual function pressure switch and boost pressure transducer (Fig. 3) on the bottom of the hydraulic assembly.

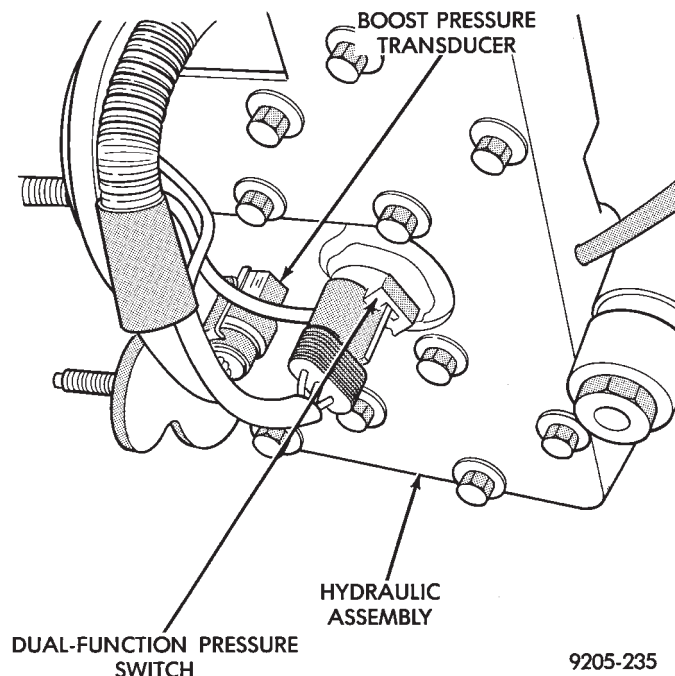

9205-235

Fig. 3 Dual Function Pressure Switch And Pressure Transducer Wiring

WARNING: WEAR EYE PROTECTION WHEN PERFORMING THE FOLLOWING PROCEDURE. SERIOUS EYE INJURY CAN RESULT FROM BRAKE FLUID CONTACTING THE EYES.

(4) **Be sure that the hydraulic system is de-pressurized.** Remove the dual function pressure switch from the hydraulic assembly using Socket, Special Tool 6607. Access to the switch is from under the vehicle using a long extension.

INSTALL

CAUTION: Be sure that the dual function pressure switch is thoroughly cleaned using Mopar Brake Parts Cleaner or an equivalent before installing it into the hydraulic assembly. Wet the O-ring seals on the switch with fresh clean brake fluid before installing it into the hydraulic assembly.

CAUTION: Do not insert dual function pressure switch into hydraulic assembly using the socket and ratchet. Cross threading of the switch may occur.

(1) Install the dual function pressure switch into the hydraulic assembly by hand until the O-ring seals are seated.

(2) Using Socket, Special Tool 6607, torque the dual function pressure switch into the hydraulic assembly to 12 N•m (9 ft. lbs.).

(3) Connect the wiring harness connectors (Fig. 3) onto the dual function pressure switch and the boost pressure transducer. Be sure the locking tabs on the connectors are fully engaged on the switches.

(4) Lower the vehicle.

(5) Turn the ignition switch to the on position and let the system pressurize. Check for any leaks at the dual function pressure switch.

(6) Fully de-pressurize the hydraulic assembly a second time to purge any air out that may have entered hydraulic assembly when the switch was removed. Turn the ignition switch to the on position and let the system pressurize again.

(7) Road test vehicle to insure that the brake system is performing correctly.

WHEEL SPEED SENSORS

Inspect tone wheels (Fig. 4) for any missing or broken teeth, this can cause erratic speed sensor signals.

Tone wheels should show no evidence of contact with the wheel speed sensor. If contact was made, determine cause and correct.

Excessive runout of the tone wheels can cause erratic wheel speed sensor signals. Replace assembly if runout exceeds approximately 0.25 mm (0.010 inch).

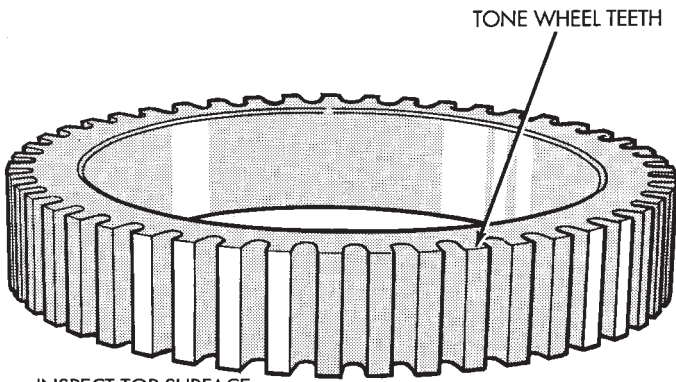

INSPECT TOP SURFACE OF TEETH FOR ANY SIGNS OF CONTACT WITH THE WHEEL SPEED SENSORS

9205-228

Fig. 4 Tone Wheel (Typical)

FRONT WHEEL SPEED SENSOR (REMOVE)

- (1) Raise vehicle and remove front wheel and tire assembly.
- (2) Remove screw from clip (Fig. 5) that holds sensor assembly grommet into fender shield.

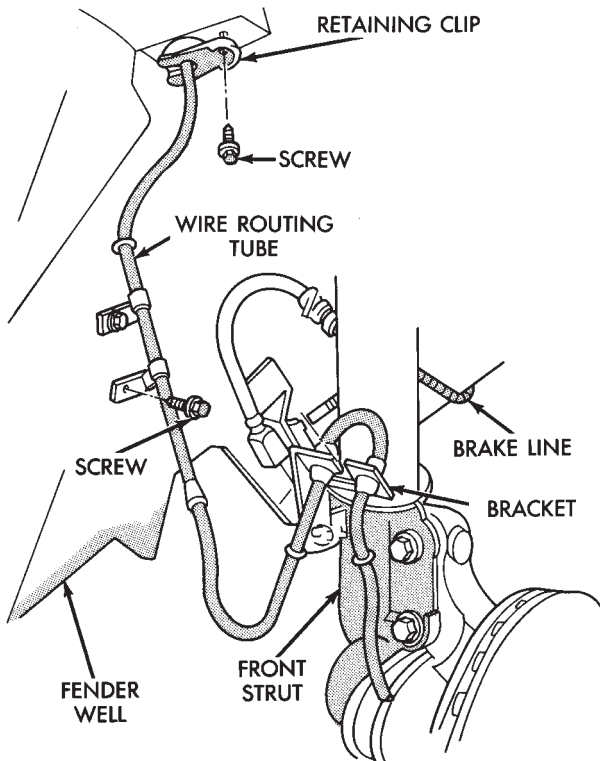

9105-114

Fig. 5 Front Wheel Speed Sensor And Cable Routing FWD/AWD

- (3) Carefully, pull sensor assembly grommet from fender shield. **When removing grommet from fender shield, do not pull on speed sensor cable.**
- (4) Unplug speed sensor cable connector, from vehicle wiring harness.

- (5) Remove the 2 screws (Fig. 5) that secure the speed sensor cable, routing tube to the fender well.
- (6) Remove the 2 sensor assembly grommets from the retainer bracket, on the strut damper (Fig. 5).
- (7) Remove speed sensor assembly to steering knuckle attaching bolt (Fig 6).
- (8) Carefully, remove sensor head from steering knuckle. If the sensor has seized, due to corrosion, use a hammer and punch to tap edge of sensor ear (Fig. 6), rocking the sensor side to side until free. **DO NOT USE PLIERS ON SENSOR HEAD.**

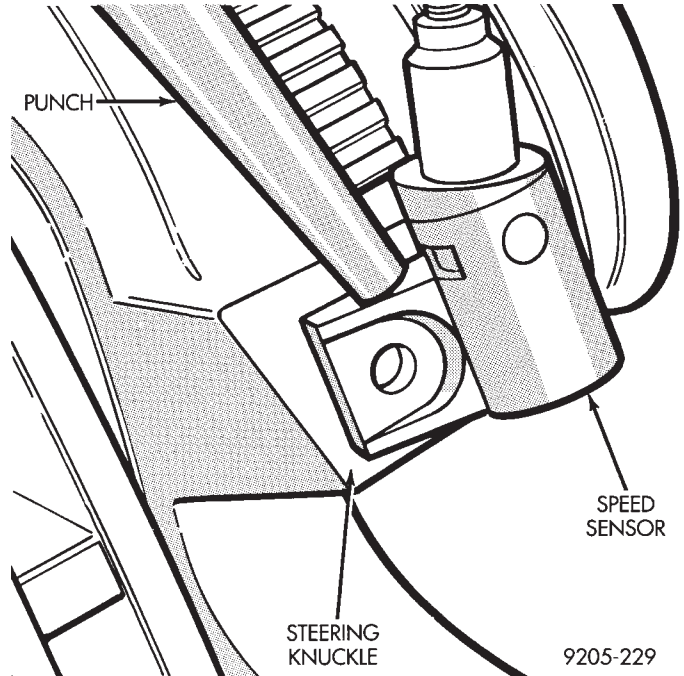

9205-229

Fig. 6 Removing Speed Sensor (Typical)

INSTALL

- (1) Connect the wheel speed sensor cable connector, to the vehicle wiring harness.
- (2) Push sensor assembly grommet into hole in fender shield. Install clip and screw (Fig 6). Torque screw to 4 N•m (35 in. lbs.).
- (3) Install speed sensor cable grommets in bracket on strut damper (Fig. 5).
- (4) Install speed sensor cable routing tube to fender well (Fig. 5). Torque both screws to 4 N•m (35 in. lbs.).
- (5) Coat the speed sensor with High Temperature Multi-purpose E.P. Grease before installing into the steering knuckle. Install speed sensor attaching screw and tighten to 7 N•m (60 in. lbs.)

CAUTION: Proper installation of wheel speed sensor cables is critical to continued system operation. Be sure that cables are routed correctly and installed in all retainers. Failure to properly route and install cables in retainers, as shown in this section. May result in contact with moving parts and/or over extension of cables, resulting in an open circuit.

REAR WHEEL SPEED SENSOR

REMOVAL FRONT WHEEL DRIVE

(1) Raise vehicle and remove rear wheel and tire assembly.

(2) Remove rear speed sensor wiring grommet retaining bracket. Remove grommet from underbody and pull harness through hole in underbody. (Fig. 7) **When removing grommet from underbody, do not pull**

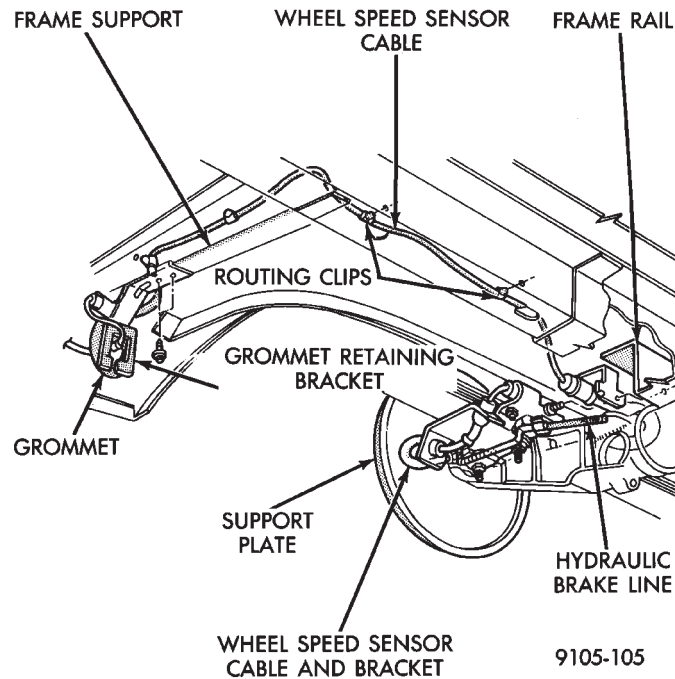

Fig. 7 Rear Wheel Speed Sensor Routing FWD

on speed sensor cable.

(3) Unplug speed sensor cable connector, from vehicle wiring harness.

(4) Remove the 4 arrow head clips which route the speed sensor wiring along the underbody (Fig. 7).

(5) Remove the wiring to frame rail attaching bracket (Fig. 7).

(6) Loosen and remove the rear axle U-bolt nuts, which retain the rear speed sensor cable assembly mounting bracket. Remove the bracket from the vehicle.

(7) Remove speed sensor head to rear brake support plate, attaching bolt (Fig. 8).

(9) Carefully, remove sensor head from rear brake support plate assembly. If the sensor has seized, due to corrosion. Use a hammer and punch (Fig. 6) to tap edge of sensor ear, rocking the sensor side to side until free. **DO NOT USE PLIERS TO TRY TO REMOVE SENSOR HEAD.**

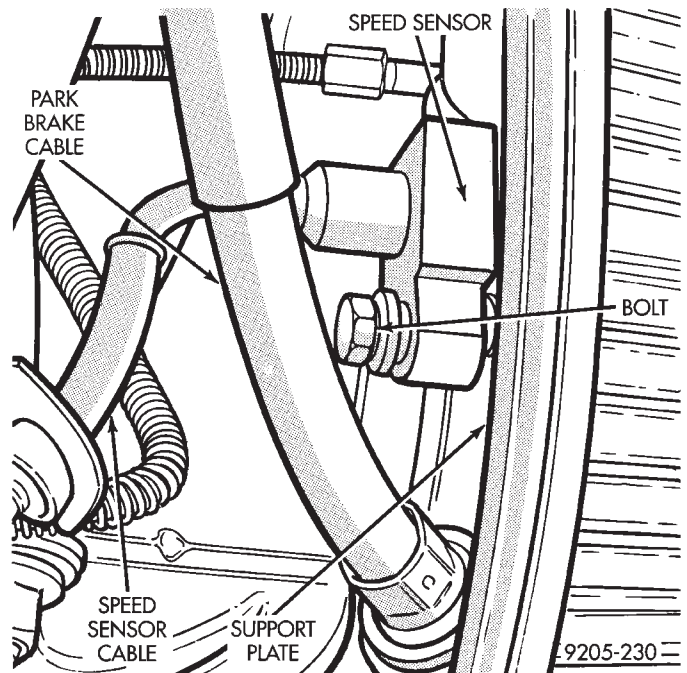

Fig. 8 Rear Speed Sensor F.W.D.

INSTALL FRONT WHEEL DRIVE.

(1) Position the rear speed sensor cable and bracket assembly on the rear axle U-bolt (Fig. 7). Install the rear axle U-bolt nuts and tighten to 88 N•m (65 ft. lbs.) torque.

(2) Coat the speed sensor head with High Temperature Multi-Purpose E.P. Grease. Install the speed sensor head into rear brake support plate. On the driver side the speed sensor wire is routed between the brake tube and the wheel brake. Torque the speed sensor to rear brake support plate attaching bolt (Fig. 8) to 7 N•m (60 in.lbs.)

(3) Bend the speed sensor cable assembly, rubber coated section toward the front of the vehicle. Position the anti-rotation tab of the sensor assembly frame rail bracket into its respective hole. Install the screw that attaches the frame rail bracket to the frame and torque to 4 N•m (35 in. lbs.)

(4) Connect the speed sensor cable assembly to the vehicle rear wiring harness. Install the speed sensor cable assembly grommet (Fig. 5) back into the underbody wiring access hole.

(5) Position the rear sensor assembly grommet retaining bracket back on the underbody, (Fig. 7) making sure the bracket does not pinch the sensor wiring. Install the 2 bracket mounting screws and torque to 4 N•m (35 in.lbs.)

(6) Route the speed sensor wiring along the vehicle frame rail (Fig. 7) and install the 4 arrow head clips.

(7) Install the rear wheel assembly and torque the wheel stud nuts to 129 N•m (95 ft.lbs.)

REMOVE ALL WHEEL DRIVE

(1) Raise vehicle and remove rear wheel and tire assembly.

(2) Remove rear speed sensor wiring grommet, retaining bracket. Remove grommet from underbody and pull harness through hole in underbody. (Fig. 9) **When removing grommet from underbody, do not pull on speed sensor cable.**

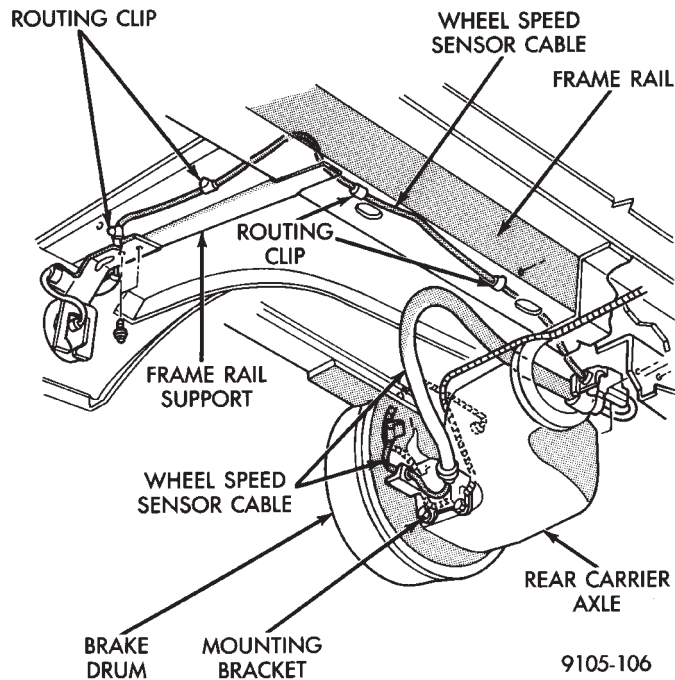

Fig. 9 Rear Wheel Speed Sensor Routing A.W.D

(3) Unplug speed sensor cable connector, from vehicle wiring harness.

(4) Remove the 4 arrow head clips which route the speed sensor cable along the underbody (Fig. 9).

(5) Remove the speed sensor cable and its frame rail routing bracket as an assembly. (Fig. 9).

(6) Remove the 2 bolts which secure the speed sensor cable assembly mounting bracket to the rear axle. Remove the bracket assembly from the vehicle by rotating the bracket and removing it from under the brake tube.

(7) Remove the speed sensor assembly attaching bolt (Fig. 10).

(9) Carefully, remove sensor head from rear axle assembly casting. If the sensor has seized, due to corrosion. Use a hammer and punch (Fig. 6) to tap edge of sensor ear, rocking the sensor side to side until free. **DO NOT USE PLIERS TO TRY TO REMOVE THE SPEED SENSOR HEAD.**

INSTALL ALL WHEEL DRIVE.

(1) Position the rear wheel speed sensor assembly bracket under the brake tube (Fig. 9). Hand start the outboard bracket attaching bolt. Align the brake tube

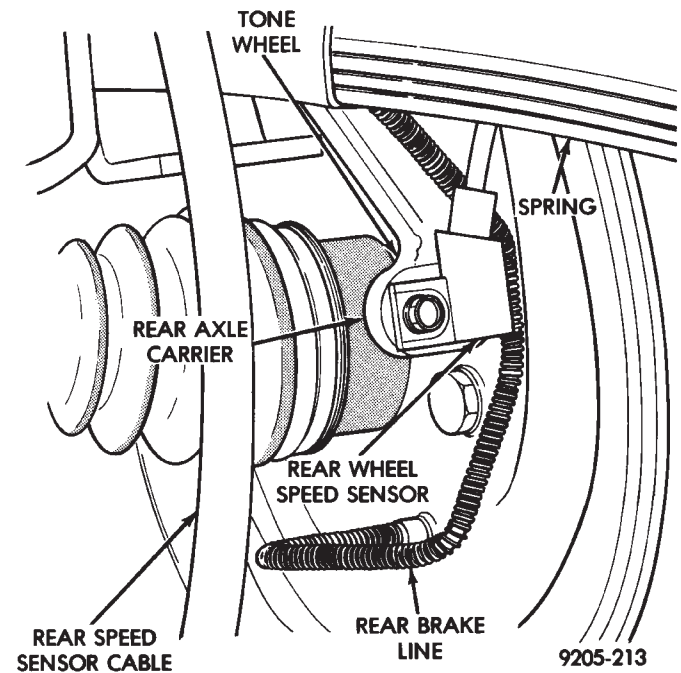

Fig. 10 Rear Wheel Speed Sensor Mounting A.W.D

clip and sensor assembly bracket and secure with bolt. Torque both bolts to 17 N•m (145 in. lbs.)

(2) Coat the wheel speed sensor head with High Temperature Multi-Purpose E.P. Grease. Install the wheel speed sensor head into the rear axle casting (Fig. 10) and install bolt. Torque the speed sensor to rear axle attaching bolt to 7 N•m (60 in.lbs.)

(3) Bend the speed sensor cable assembly, rubber coated section toward the rear of the vehicle. Position the anti-rotation tab of the sensor assembly frame rail bracket, into its respective hole. Install the screw that attaches the frame rail bracket to the frame and torque to 4 N•m (35 in. lbs.).

(4) Connect the speed sensor cable assembly to the vehicle rear wiring harness. Install the speed sensor cable assembly wiring grommet (Fig. 9) back into the underbody wiring access hole.

(5) Position the rear speed sensor cable assembly grommet retaining bracket on the underbody, (Fig. 9) making sure the bracket does not pinch the sensor wiring. Install the 2 bracket mounting screws and torque to 4 N•m (35 in.lbs.).

(6) Route the speed sensor wiring along the vehicle frame rail (Fig. 9) and install the 4 arrow head clips.

(7) Install the rear wheel assembly and torque the wheel stud nuts to 129 N•m (95 ft.lbs.)

SPECIFICATIONS

BRAKE SYSTEM COMPONENTS

FRONT BRAKES—DISC

Type.....	Single Piston-Pin Slider-Disc
Caliper Bore Diameter	60mm
Adjustment	Automatic
Piston Material.....	Glass Filled Phenolic
Piston Boot Type.....	Press In EPDM Rubber
Disc Type All Bodies	Vented
Disc Diameter-Outside	260 mm or 283 mm
Runout - Maximum Allowable T.I.R.*13 mm (.005 in.)
Parallelism-Total Variation in Thickness in 360° of Rotation013 mm (.0005 in.)
Brake Shoes And Linings.....	Riveted

REAR BRAKES—DRUM

Type.....	Duo-Servo
Adjustment	Automatic
Drum Diameter	231 mm (9 in.)
Wheel Cylinder Diameter.....	19.0 mm (3/4 in.)
Brake Shoes And Linings.....	Riveted

9205-231

BRAKE ACTUATION SYSTEM

ACTUATION:	Power Brakes Standard
Hydraulic System.....	Dual-Diagonally Split
MASTER CYLINDER:	
Type.....	Dual-Tandem-Chrysler
Body Material	Anodized Aluminum
Reservoir Material	Glass Reinforced Nylon
Bore and Stroke	24.0mm x 32.8mm
Displacement Split	50/50
Outlet Port Threads.....	3/8 x 24
Outlet Fitting Type	45 Inverted Flare
ABS Hydraulic Assembly Fitting Type	ISO Style Flare
Pedal Ratio	3.14
BOOSTER:	
Make.....	Bendix
Mounting Studs	M8 x 1.25
Type.....	270mm
Boost @ 20" HG.....	3800 N•m (850 lbs.)
HYDRAULIC VALVE:	
Material.....	Brass
Function.....	Warning Light Switch (Latching)
PROPORTIONING VALVE	
Material.....	Aluminum
Function.....	Height Sensing (Dual Circuit)

9205-232



TIGHTENING REFERENCE

DESCRIPTION	TORQUE
Hydraulic Brake Tubes To All Fittings (If Not Specified)	17 N•m (143 in. lbs.)
Brake Hoses To Calipers (Banjo Bolts).....	33 N•m (24 ft. lbs.)
Brake Hose Intermediate Bracket	11 N•m (95 in. lbs.)
Master Cylinder To Brake Booster Mounting Nuts.....	28 N•m (250 in. lbs.)
Brake Booster Assembly to Dash Panel	28 N•m (250 in. lbs.)
Wheel Cylinder to Rear Brake Support Plate	8 N•m (75 in. lbs.)
Wheel Cylinder Bleed Screw	10 N•m (80 in. lbs.)
Brake Support Plate To Rear Axle Mounting Bolts.....	109 N•m (80 ft. lbs.)
Wheel Stud Lug Nuts	110 - 135 N•m (85 - 115 ft. lbs.)
Caliper Adapter To Steering Knuckle Mounting Bolts	217 N•m (160 ft. lbs.)
Caliper Guide Pin Bolts	41 N•m (30 ft. lbs.)
Bearing Retainer Mounting Bolt	28 N•m (250 in. lbs.)
Caliper Bleed Screw	15 N•m (125 in. lbs.)
Brake Light Switch Mounting Bracket Screw	8 N•m (75 in. lbs.)
Parking Brake Assembly Mounting	28 N•m (250 in. lbs.)

9205-233

