

TURN SIGNALS AND HAZARD WARNING FLASHER

CONTENTS

	page		page
CHIME FUNCTION	1	GENERAL INFORMATION	1
ELECTRONIC COMBINATION FLASHER	1	HAZARD WARNING SWITCH	1
FLASHER SYSTEM DIAGNOSIS	3	MULTI-FUNCTION SWITCH	1

GENERAL INFORMATION

WARNING: ON VEHICLES EQUIPPED WITH AIRBAG, SEE GROUP 8M, RESTRAINT SYSTEMS FOR AIRBAG REMOVAL PROCEDURES.

The turn signals are apart of the multi-function switch. The switch contains the turn signal, headlamp beam select, headlamp optical horn, windshield wiper, pulse wipe and windshield washer controls. The integrated switch is mounted on the left side of the steering column. The driver moves the lever upward for the right signal and downward for the left signal to flash. After completion of a turn the system is canceled automatically.

If only momentary signaling such as indication of a lane change is desired, the switch is actuated to a left or right intermediate detent position. In this position the signal lamps flash as described above, but the switch returns to the OFF position as the lever is released.

Activate the system and the indicator lamps will flash in unison with the turn signal lamps. This shows that the system is operating.

HAZARD WARNING SWITCH

Refer to Group 8E, Instrument Panel, Headlamp Switch.

CHIME FUNCTION

The chime will sound after the vehicle has traveled a distance of 0.6 miles at a speed above 15 miles per hour.

MULTI-FUNCTION SWITCH

The multi-function switch contains:

- Electrical circuitry for turn signal
- Headlamp beam select
- Headlamp optical horn
- Windshield wiper
- Pulse wipe
- Windshield washer switching

This integrated switch assembly is mounted to the left hand side of the steering column. If any function of the switch fails, the entire switch assembly must be replaced. Refer to Fig. 1 for diagnosis.

SWITCH TEST

- (1) Disconnect the negative battery cable.
- (2) Remove the upper and lower column covers to gain access to the switch connector.
- (3) Remove switch connector.
- (4) Using an ohmmeter, test for continuity between the terminals of the switch as shown in the following continuity charts (Fig 2 and 3).
- (5) If reading are incorrect, replace switch.

REMOVAL

- (1) Disconnect battery negative cable.
- (2) Tilt column only remove tilt lever.
- (3) Remove both upper and lower steering column covers.
- (4) Remove multi-function switch tamper proof mounting screws (Fig.4).
- (5) Gently pull switch away from column and loosen connector screw. The screw will remain in the connector.
- (6) Remove wiring connector from multi-function switch.

INSTALLATION

- (1) Install wiring connector to switch and tighten connector retaining screw to 2 N•m (17 in. lbs.) torque.
- (2) Mount multi-function switch to column and tighten retaining screws to 2 N•m (17 in. lbs.) torque.
- (3) Install steering column covers. Tighten retaining screws to 2 N•m (17 in. lbs.) torque.
- (4) Tilt column only, install the tilt lever.
- (5) Connect battery negative cable.
- (6) Check the switch functions for proper operation.

ELECTRONIC COMBINATION FLASHER

The module provides both turn signal and hazard flasher operation. The flasher plugs into the lower left corner of relay bank to the left of the fuse block. To gain access to the flasher, remove the lower steering column cover. The flash rate for the turn signal and hazard warning flasher is constant for any number of lamps. Depending on exact current draw of lamps, there should be between 60 and 120 flashes per minute. If a lamp or circuit to a lamp is open, the

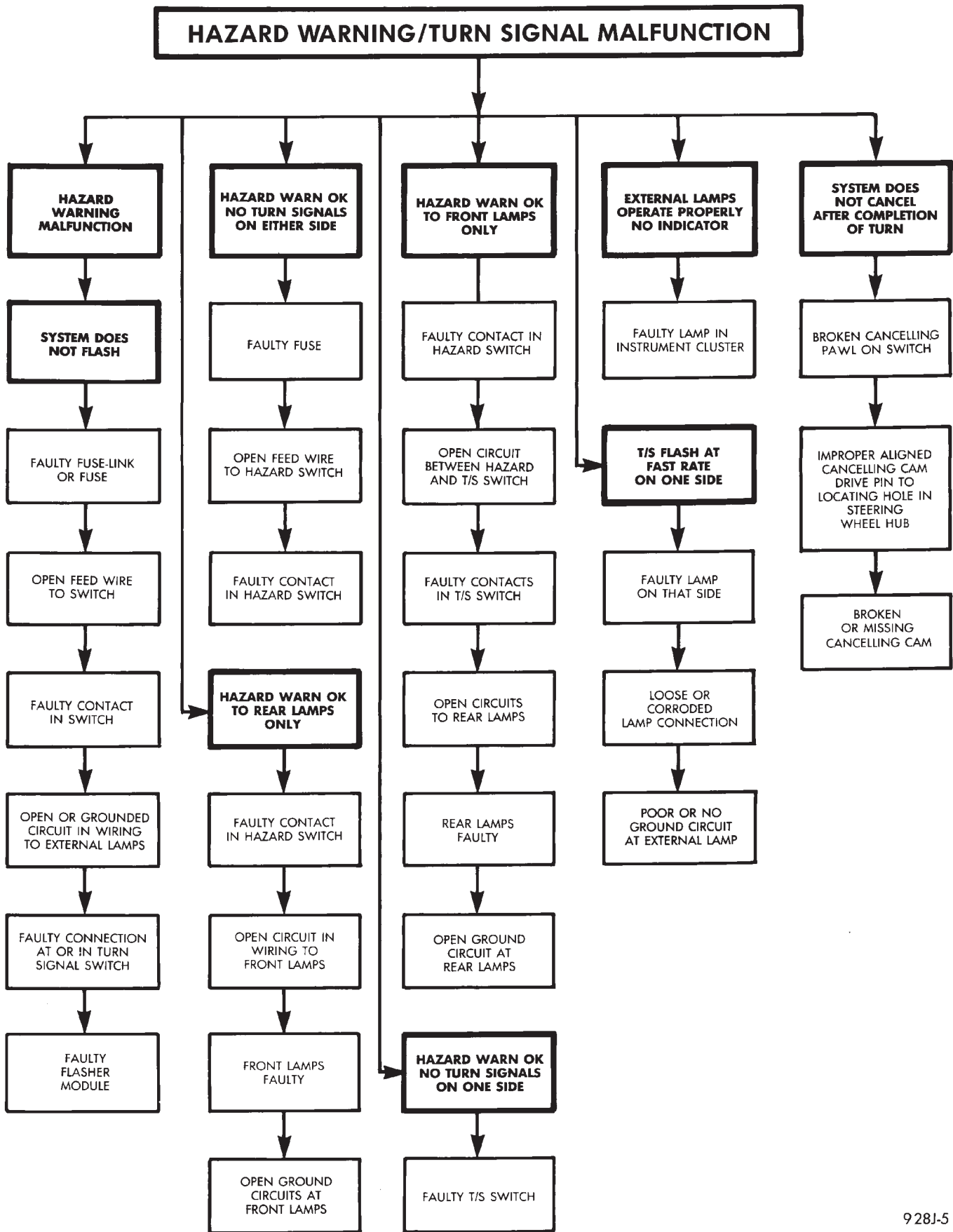
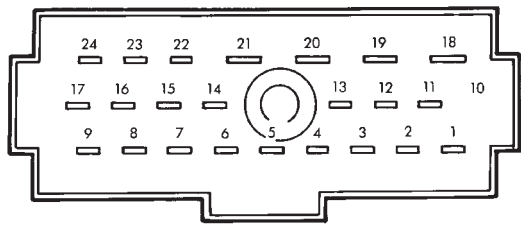

Fig. 1 Turn Signal and Hazard Warning Flasher Diagnosis



VIEW FROM TERMINAL CASE

SWITCH POSITIONS		CONTINUITY BETWEEN
TURN SIGNAL	HAZARD WARNING	
NEUTRAL	OFF	12 AND 14 AND 15
LEFT	OFF	15 AND 16 AND 17
LEFT	OFF	12 AND 14
LEFT	OFF	22 AND 23 WITH OPTIONAL CORNER LAMPS
RIGHT	OFF	11 AND 12 AND 17
RIGHT	OFF	14 AND 15
RIGHT	OFF	23 AND 24 WITH OPTIONAL CORNER LAMPS
NEUTRAL	ON	11 AND 12 AND 13 AND 15 AND 16

918J-6

Fig. 2 Turn Signal and Hazard Switch Continuity

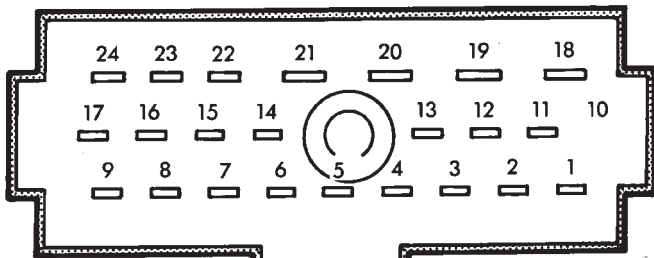

VIEW FROM TERMINAL SIDE

SWITCH POSITION	CONTINUITY BETWEEN
LOW BEAM	18 AND 19
HIGH BEAM	19 AND 20
OPTICAL HORN	20 AND 21

908J-5

Fig. 3 Beam Select Switch Continuity

flash rate for that side of the vehicle may double. The turn signal and hazard warning functions are each fused separately but from the same fuse link (Fig. 5).

FLASHER SYSTEM DIAGNOSIS

(1) Hazard warning and turn signal flasher are not working (Fig. 6):

- Check electronic combination flasher
- Check both fuses
- Check fuse link
- Check wiring
- Repair as necessary
- Confirm proper operation

(2) Actuate hazard warning flasher switch, located in headlamp POD switch.

- Observe lamps for proper operation
- Identify any non-flashing lamp

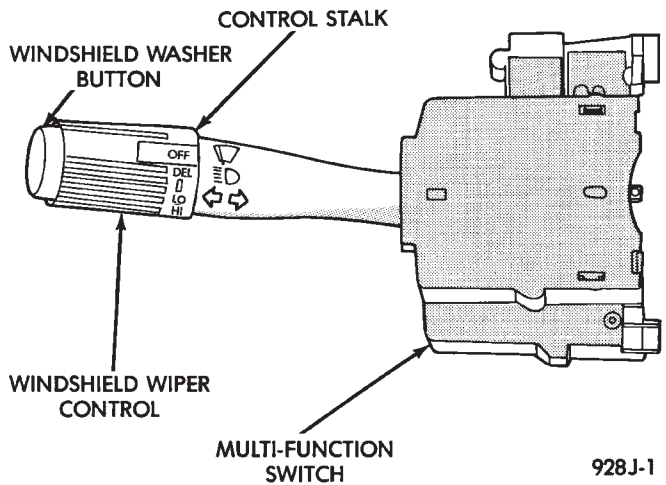

928J-1

Fig. 4 Multi-Function Switch

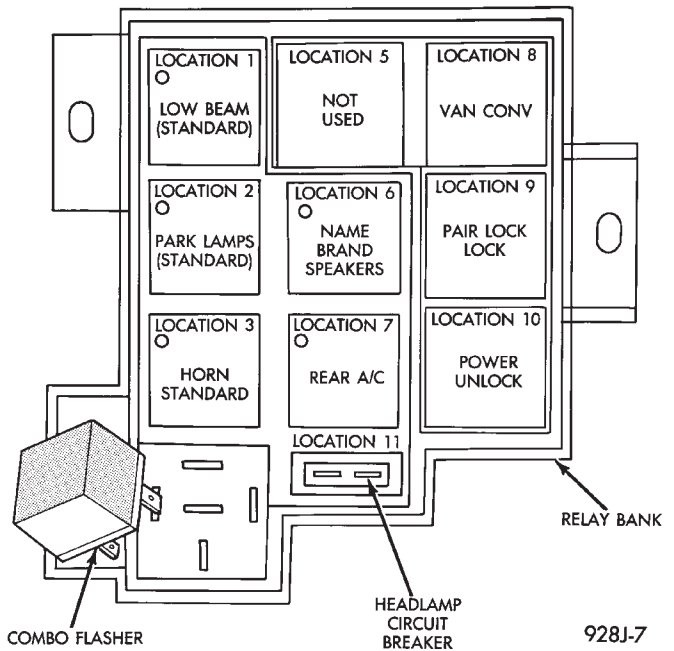

928J-7

Fig. 5 Relay Bank

- Check and replace any defective lamp
 - Hazard warning flasher is not operating at all, check fuse or wiring. Repair as necessary.
 - Confirm proper operation. If OK, go to step 3.
- (3) The hazard warning flasher system is operating properly:
- Turn OFF hazard warning flasher switch
 - Turn ignition switch ON
 - Actuate the turn signal lever to both right and left sides to confirm proper operation of lamps for each side.
 - Check and replace any defective lamp
 - Confirm proper operation. If not go to step 4.
- (4) If hazard warning flasher system is OK and the turn signal is not operating properly:

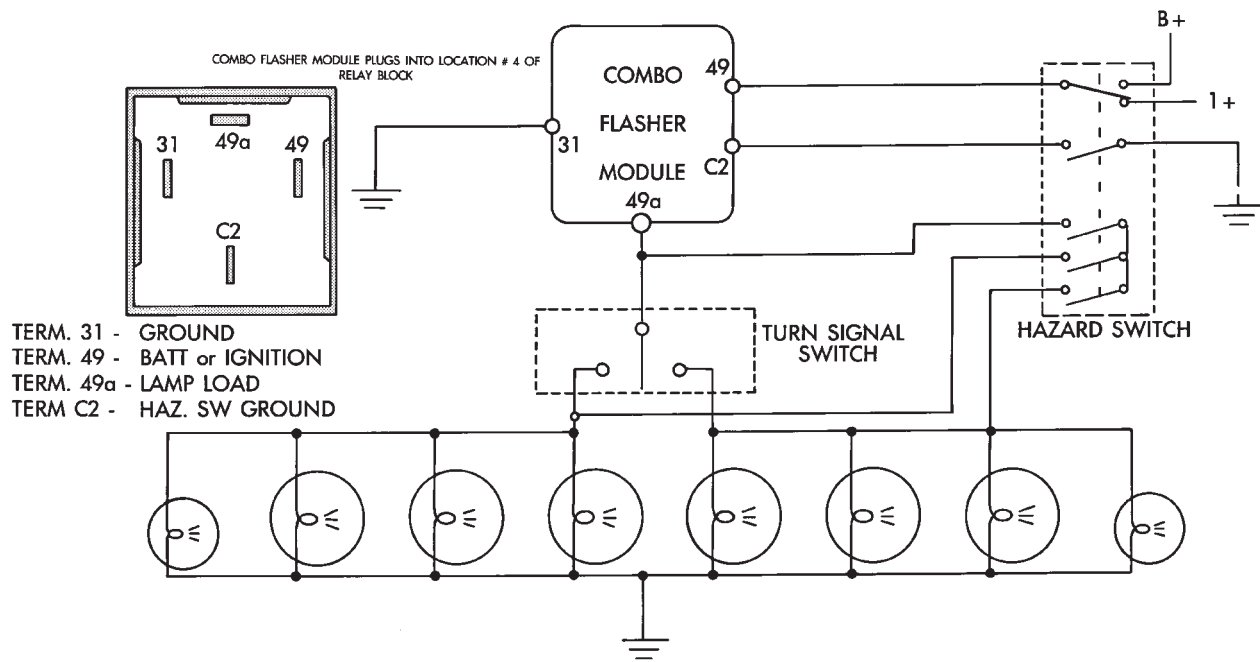

Fig. 6 Combination Flasher Schematic Diagram

- Turn signal appears to be defective on one side, problem maybe in the turn signal switch or wiring?
- Turn signal is not operating at all, check fuse or wiring. Repair as necessary.
- Confirm proper operation