

EXHAUST SYSTEM AND INTAKE MANIFOLD

CONTENTS

	page		page
EXHAUST SYSTEM DIAGNOSIS	3	SERVICE PROCEDURES	4
GENERAL INFORMATION	1		

GENERAL INFORMATION

Throughout this group, references may be made to a particular vehicle by letter or number designation. A chart showing the breakdown of these designations is included in the Introduction Section at the front of this service manual.

EXHAUST SYSTEMS

The exhaust systems are produced in several configurations, depending on engine and vehicle (Fig. 1). All wheel drive vehicles have underfloor catalytic converters, front wheel drive vehicles require front mounted catalytic converters. Tail pipes, mufflers,

and resonators are sized and tuned to each vehicle/powertrain combination (Fig. 2).

CATALYTIC CONVERTERS

There is no regularly scheduled maintenance on any Chrysler catalytic converter. If damaged, the converter must be replaced.

CAUTION: Due to exterior physical similarities of some catalytic converters with pipe assemblies, extreme care should be taken with replacement parts. There are internal converter differences required in some parts of the country (particularly California vehicles).

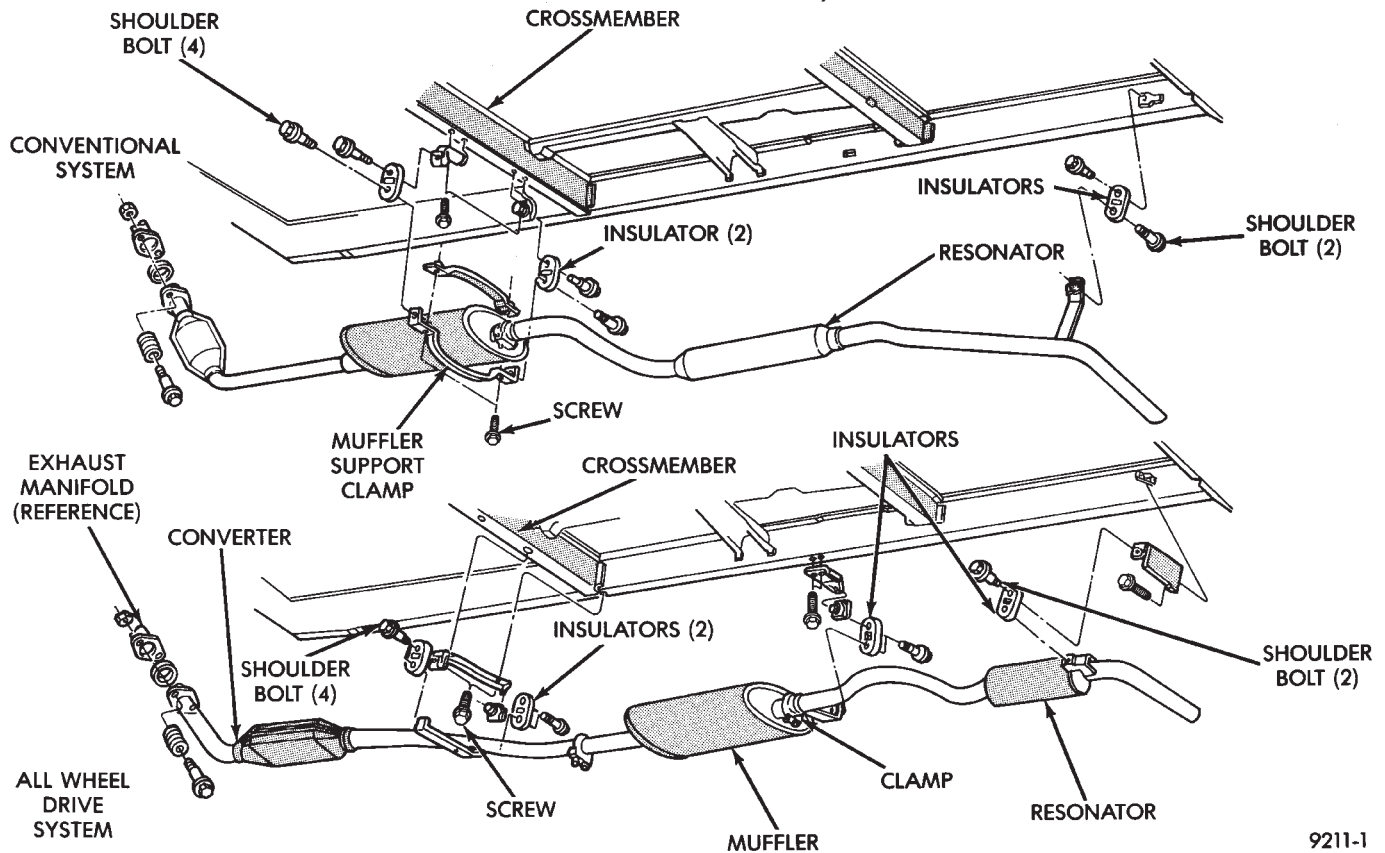

9211-1

Fig. 1 Exhaust System (All Vehicles)

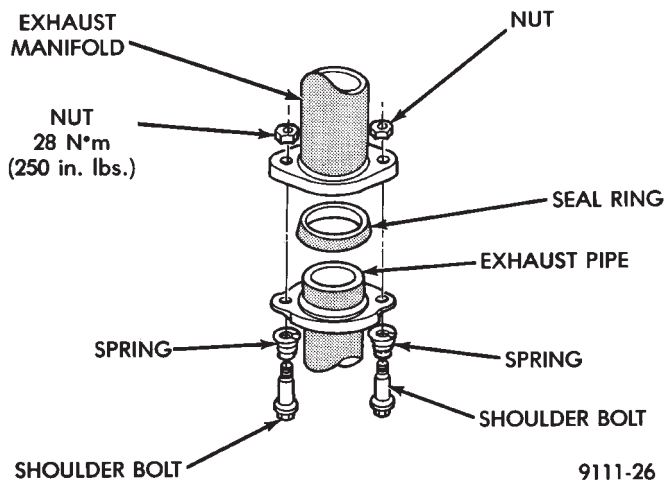

Fig. 2 Ball-Joint Connection

SPECIAL EXHAUST BALL-JOINT COUPLING

A special exhaust ball-joint coupling (Fig. 2) is used to secure the exhaust pipe to the engine manifold. This living joint actually moves back and forth as the engine moves, preventing breakage that could occur from the back-and-forth motion of a transverse mounted engine.

The exhaust ball joint has two bolts, two springs, two lock nuts and a ball joint seal ring that is a separate part from the exhaust pipe.

EXHAUST GAS RECIRCULATION (EGR)

To assist in the control of oxides of nitrogen (NOx) in engine exhaust, all engines are equipped with an exhaust gas recirculation system. The use of exhaust gas to dilute incoming air/fuel mixtures lowers peak flame temperatures during combustion, thus limiting the formation of NOx.

Exhaust gases are taken from opening in the exhaust manifold passage to the intake manifold. REFER TO SECTION 25 FOR A COMPLETE DESCRIPTION, DIAGNOSIS AND SERVICE PROCEDURES ON THE EXHAUST GAS RECIRCULATION SYSTEM AND COMPONENTS.

HEAT SHIELDS

Heat shields (Fig. 3) are needed to protect both the vehicle and the environment from the high temperatures developed near the catalytic converters.

See Body and Sheet Metal, Group 23 for service procedures.

Avoid application of rust prevention compounds or undercoating materials to exhaust system floor pan heat shields on cars so equipped. Light over spray near the edges is permitted. Application of coating will greatly reduce the efficiency of the heat shields resulting in excessive floor pan temperatures and objectionable fumes.

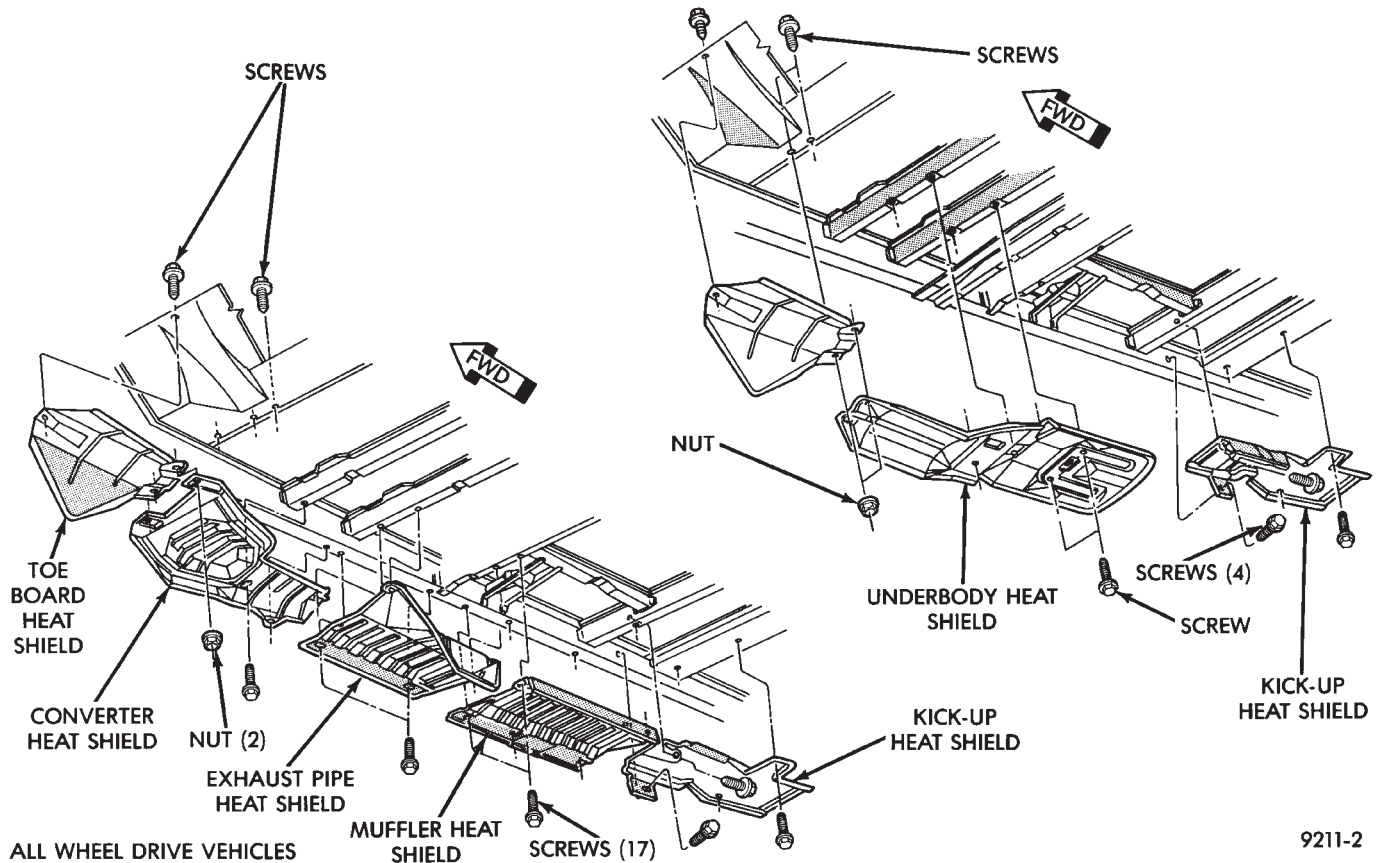

Fig. 3 Heat Shields

The combustion reaction caused by the catalyst releases additional heat in the exhaust system. Causing temperature increases in the area of the reactor under severe operating conditions. Such conditions can exist when the engine misfires or otherwise does not operate at peak efficiency. **Do not** remove spark plug wires from plugs or by any other means short out cylinders if exhaust system is equipped with catalytic converter. Failure of the catalytic converter

can occur due to temperature increases caused by unburned fuel passing through the converter.

The use of the catalysts also involves some non-automotive problems. Unleaded gasoline must be used to avoid poisoning the catalyst core. Do not allow engine to operate at fast idle for extended periods (over 5 minutes). This condition may result in excessive exhaust system and floor pan temperatures.

EXHAUST SYSTEM DIAGNOSIS

Condition	Possible Cause	Correction
EXCESSIVE EXHAUST NOISE (UNDER HOOD)	(a) Exhaust manifold cracked or broken	(a) Replace manifold
	(b) Manifold to cylinder head leak	(b) Tighten manifold and/or replace gasket
	(c) EGR Valve Leakage	(c)
	a, EGR Valve to Manifold Gasket	a, Tighten nuts or replace gasket
	b, EGR Valve to EGR Tube Gasket	b, Tighten nuts or replace gasket
c, EGR Tube to Manifold Tube Nut	c, Tighten tube nut	
(d) Exhaust Flex Joint	(d)	
a, Spring height, installed not correct	a, Check spring height, both sides (specification is 32.5 mm, 1.28 inch) look for source of spring height variation if out of specification.	
b, Exhaust sealing ring defective	b, Inspect seal for damage on round spherical surface. If no damage is evident, check for exhaust obstruction causing high back pressure on heavy acceleration.	
(e) Pipe and shell noise from front exhaust pipe	(e) Characteristic of single wall pipes.	
EXCESSIVE EXHAUST NOISE	(a) Leaks at pipe joints	(a) Tighten clamps at leaking joints
	(b) Burned or blown or rusted out muffler, tailpipe of exhaust pipe.	(b) Replace muffler or muffler tailpipe or exhaust pipe.
	(c) Restriction in muffler or tailpipe	(c) Remove restriction, if possible or replace as necessary.
	(d) Converter material in muffler	(d) Replace muffler and converter assemblies. Check fuel injection and ignition systems for proper operation.

SERVICE PROCEDURES

EXHAUST PIPES, MUFFLERS AND TAILPIPES

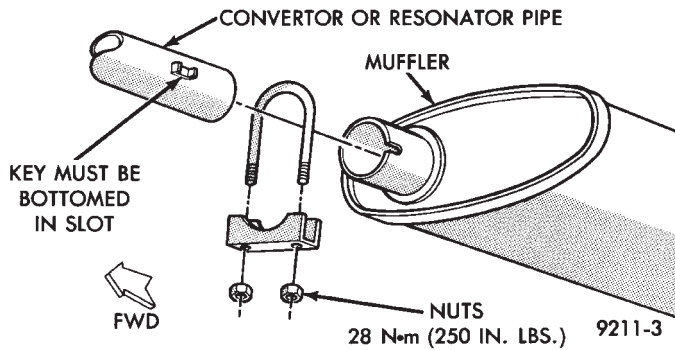

Fig. 4 Exhaust (Converter/Resonator) Pipe to Muffler

REMOVAL

- (1) Raise vehicle on hoist and apply penetrating oil to clamp bolts and nuts of component being removed.
- (2) Remove clamps and supports (Figs. 4, 5, and 6) from exhaust system to permit alignment of parts during assembly.
- (3) When removing tailpipe, raise rear of vehicle to relieve body weight from rear springs to provide clearance between pipe and rear axle parts.
- (4) Clean ends of pipes or muffler to assure mating of all parts. Discard broken or worn insulators, rusted clamps, supports and attaching parts.

When replacement is required on any component of the exhaust system. It is important that original equipment parts (or their equivalent) be used;

• To insure proper alignment with other parts in the system.

• Provide acceptable exhaust noise levels and does not change exhaust system back pressure that could effect emissions and performance.

- To insure proper alignment with other parts in the system.
- Provide acceptable exhaust noise levels and does not change exhaust system back pressure that could effect emissions and performance.

INSTALLATION

- (1) Assemble pipes, muffler supports and clamps loosely to permit alignment of all parts.
- (2) Beginning at front of system, align and clamp each component to maintain position and proper clearance with underbody parts.
- (3) Tighten all clamps and supports to the proper torques and clearances.

INTAKE AND EXHAUST MANIFOLDS—TBI ENGINE

INTAKE MANIFOLDS:

Naturally Aspirated Die-cast aluminum long-branch fan design with remote plenum. The throttle body is installed on the upper plenum of the manifold.

EXHAUST MANIFOLDS:

All high strength iron casting that intermesh with

the intake manifold. For standard engines a four branch design collects and directs exhaust gases to the conical (articulated joint connection) outlet.

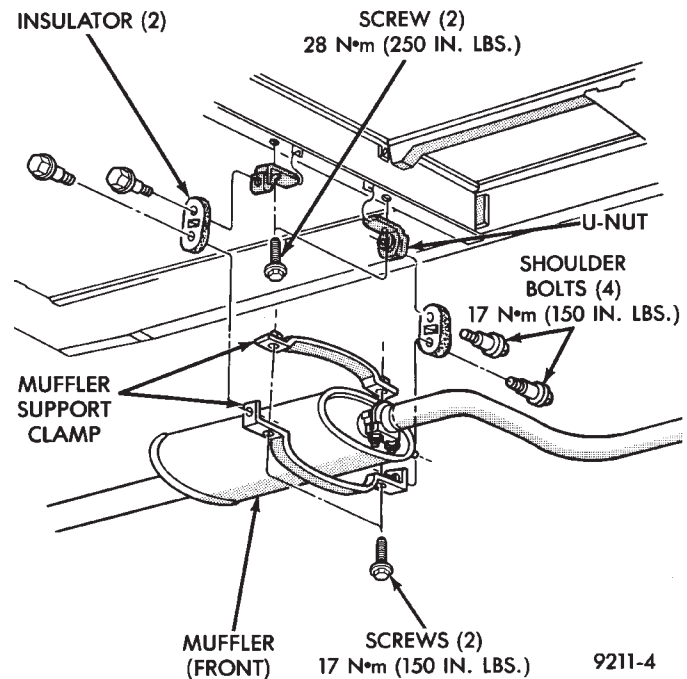

Fig. 5 Muffler to Tail Pipe

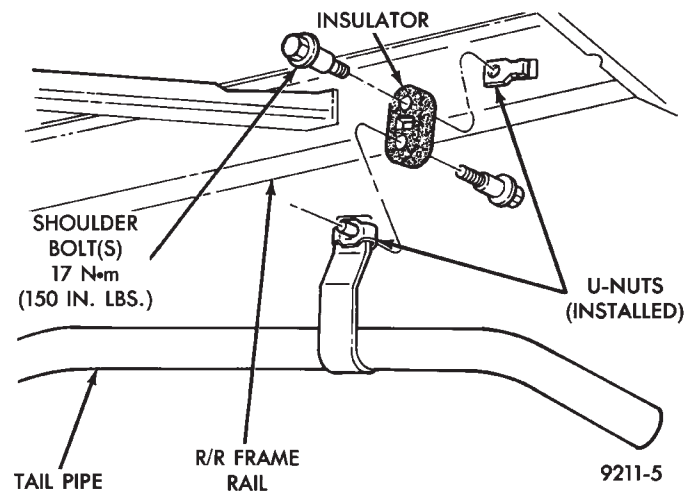

Fig. 6 Rear Tail Pipe Bracket and Insulator

THROTTLE BODY AIR HEATER

The throttle body air heater (Fig. 7) is attached to the exhaust manifold and is removable.

Inspect air heater connector tube; replace if damaged. Refer to Emission Control Systems, Group 25, for diagnostic and service procedures on the air control valve and temperature sensor located in the air cleaner.

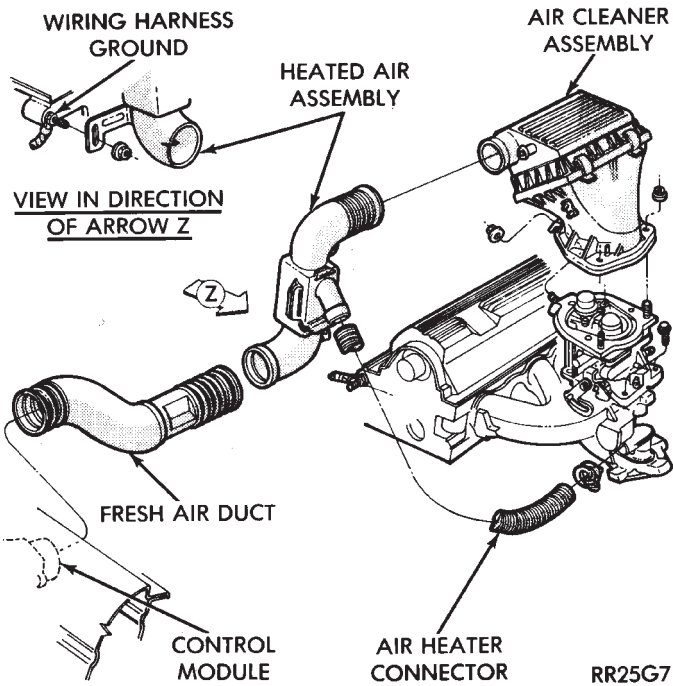

Fig. 7 Air Heater TBI Engines

INTAKE AND EXHAUST MANIFOLDS SERVICE—TBI ENGINE Intake and exhaust manifolds use a one piece gasket. Service procedures requiring removal and installation (of either) must include both manifolds.

FUEL SYSTEM PRESSURE RELEASE PROCEDURE

The Fuel System is under a constant pressure of at least 265 kPa (39 psi). Before servicing the fuel pump, fuel lines, fuel filter, throttle body or fuel injector, the fuel system pressure must be released.

- (a) Loosen fuel filler cap to release fuel tank pressure.
- (b) Disconnect injector wiring harness from engine harness.
- (c) Connect a jumper wire to ground terminal Number 1 of the injector harness (Fig. 8) to engine ground.
- (d) Connect a jumper wire to the positive terminal Number 2 of the injector harness (Fig. 8) and touch the battery positive post for no longer than 5 seconds. This releases system pressure.
- (e) Remove jumper wires.
- (f) Continue fuel system service.

REMOVAL

- (1) Perform fuel system pressure release procedure **before attempting any repairs.**
- (2) Disconnect negative battery cable. Drain cooling system. Refer to Cooling System, Group 7 for procedure.

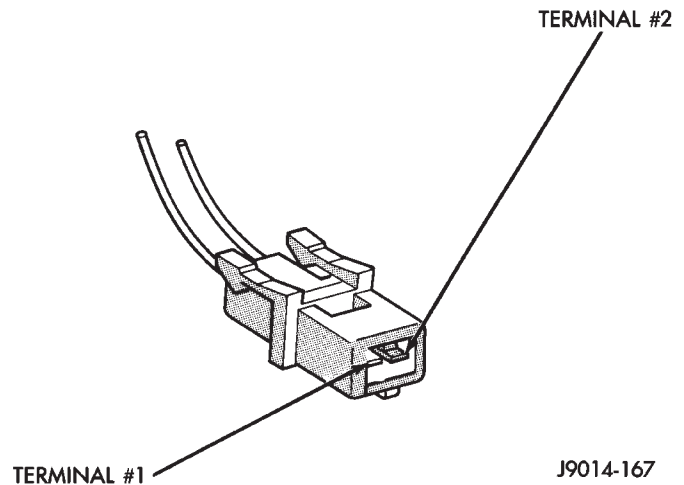

Fig. 8 Injector Harness Connector

- (3) Remove air cleaner and disconnect all vacuum lines, electrical wiring and fuel lines from throttle body.
- (4) Remove throttle linkage.
- (5) Loosen power steering pump and remove belt.
- (6) Remove power brake vacuum hose from intake manifold.

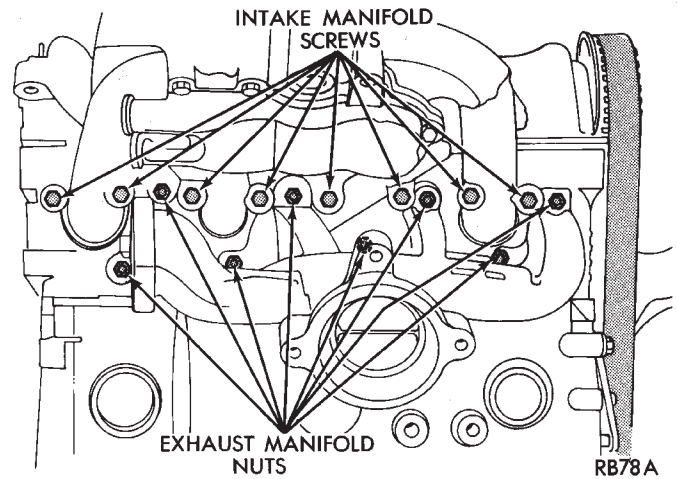

Fig. 9 Intake and Exhaust Manifold Attaching Points—2.5L Engines

- (7) Disconnect EGR tube from intake manifold and remove water hoses from water crossover.
- (8) Raise vehicle and remove exhaust pipe from manifold.
- (9) Remove power steering pump assembly and set aside.
- (10) Remove intake manifold retaining screws. (Fig. 9)
- (11) Lower vehicle and remove intake manifold.
- (12) Remove exhaust manifold retaining nuts (Fig. 9).
- (13) Remove exhaust manifold.

CLEANING AND INSPECTION

(1) Discard gaskets and clean all gasket surfaces on both manifolds and on cylinder head.

(2) Test gasket surfaces of manifolds for flatness with a straight edge. Surfaces must be flat within 0.15mm per 300mm (.006 in. per foot) of manifold length.

(3) Inspect manifolds for cracks and distortion.

INSTALLATION

(1) Install a new intake and exhaust manifold gasket. Coat steel gasket lightly with Gasket Sealer on manifold side. **Do not** coat composition gasket with (any) sealer.

(2) Set exhaust manifold in place. Tighten retaining nuts starting at center and progressing outward in both directions to 23 N•m (200 in. lbs.) (Fig. 9). Repeat this procedure until all nuts are at specified torque.

(3) Set intake manifold in place.

(4) Raise vehicle and tighten retaining screws starting at center and progressing outward in both directions to 23 N•m (200 in. lbs.) (Fig. 9). Repeat this procedure until all screws are at specified torque.

(5) Reverse removal procedures 1-9 for installation.

(6) With the DRB II use ASD Fuel System Test to pressurize system to check for leaks.

CAUTION: When using the ASD Fuel System Test, The Auto Shutdown (ASD) Relay will remain energized for 7 minutes or until the ignition switch is turned to the OFF position, or Stop All Test is selected.

INTAKE AND EXHAUST MANIFOLDS — 3.0L ENGINE

The intake system has a large air intake plenum of aluminum alloy and a cross type intake manifold (Fig. 2).

The exhaust manifolds are made of ductile cast iron with the front bank and rear bank independent of each other. The exhaust from the front bank exhaust manifold is led through on exhaust crossover pipe to be combined with the rear bank exhaust at the exhaust outlet to the exhaust pipe (Fig. 2).

INTAKE PLENUM/MANIFOLD**REMOVAL**

(1) Perform fuel system pressure release procedure **(before attempting any repairs)**.

(2) Disconnect negative battery cable. Drain cooling system. See Cooling System, Group 7.

(3) Remove air cleaner to throttle body hose (Fig. 4).

FUEL SYSTEM PRESSURE RELEASE PROCEDURE

The MPI fuel system is under a constant pressure of approximately 330 kPa (48 psi). Before servicing the fuel pump, fuel lines, fuel filter, throttle body or fuel injector, the fuel system pressure must be released.

(a) Loosen fuel filler cap to release fuel tank pressure.

(b) Disconnect injector wiring harness from engine harness.

(c) Connect a jumper wire to ground terminal Number 1 of the injector harness (Fig. 3) to engine ground.

(d) Connect a jumper wire to the positive terminal Number 2 of the injector harness (Fig. 3) and touch the battery positive post for no longer than 5 seconds. This releases system pressure.

(e) Remove jumper wires.

(f) Continue fuel system service.

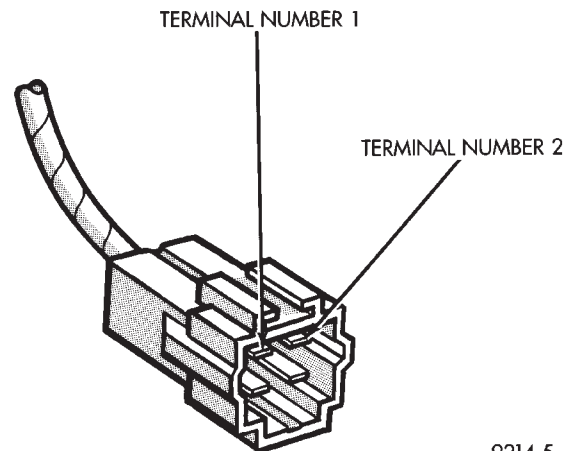

9214-5

Fig. 1 Injector Harness Connector

(4) Remove throttle cable and transaxle kickdown linkage (Fig. 5).

(5) Remove automatic idle speed (AIS) motor and throttle position sensor (TPS) wiring connectors from throttle body. (Fig. 6).

(6) Remove vacuum hose harness from throttle body (Fig. 6).

(7) Remove PCV and Brake booster hoses from Air Intake Plenum.

(8) Remove Ignition Coil from Intake Plenum (Fig. 7).

(9) Remove wiring connectors from coolant temperature sensor (Fig. 8).

(10) Remove vacuum connections from Air Intake Plenum vacuum connector.

(11) Remove fuel hoses from fuel rail (Fig. 8).

WARNING: WRAP SHOP TOWELS AROUND HOSES TO CATCH ANY GASOLINE SPILLAGE.

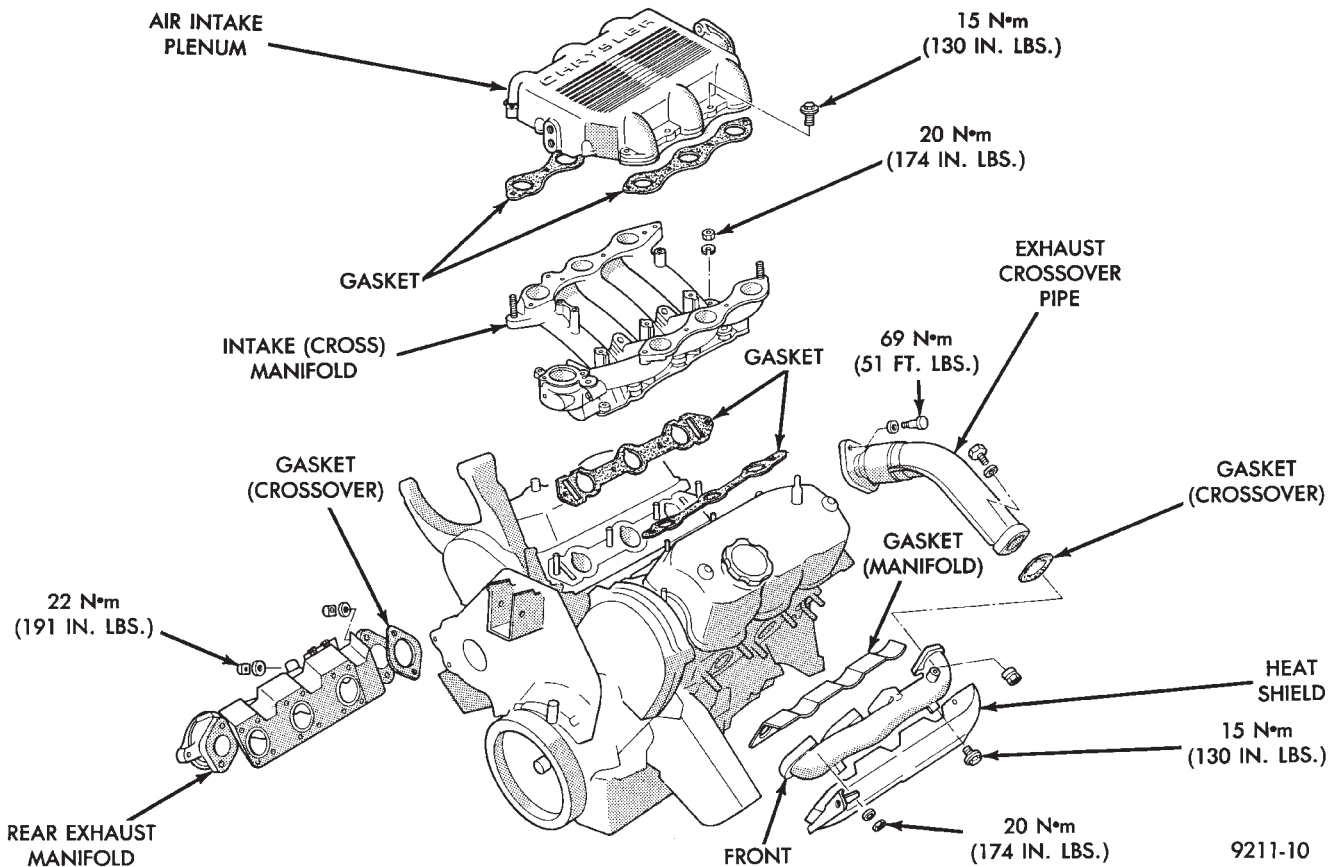

Fig. 2 Intake and Exhaust Manifolds— 3.0L Engine

(12) Remove (8) Fasteners from Air Intake Plenum to Intake Manifold (Fig. 9).

(13) Remove Air Intake Plenum (Fig. 10).

(14) Cover intake manifold with suitable cover when servicing.

(15) Remove vacuum hoses from fuel rail and fuel pressure regulator (Fig. 11).

(16) Disconnect Fuel Injector wiring harness from engine wiring harness (Fig. 12).

(17) Remove fuel pressure regulator attaching bolts and remove regulator from rail (Fig. 13). **Be careful not to damage the rubber injector O-rings upon removal from the ports.**

(18) Remove fuel rail attaching bolts and lift fuel rail assembly from intake manifold.

(19) Separate radiator hose from thermostat housing and heater hose from heater pipe.

(20) Remove (8) nut and washer assemblies and remove intake manifold (Fig. 1).

INSPECTION

Check for:

- Damage and cracks of each section (Fig. 13).
- Clogged water passages in end cross overs.
- Check for distortion of the cylinder head mounting surface using a straightedge and thickness gauge (Fig. 14). Refer to (Fig. 15) for Specifications.

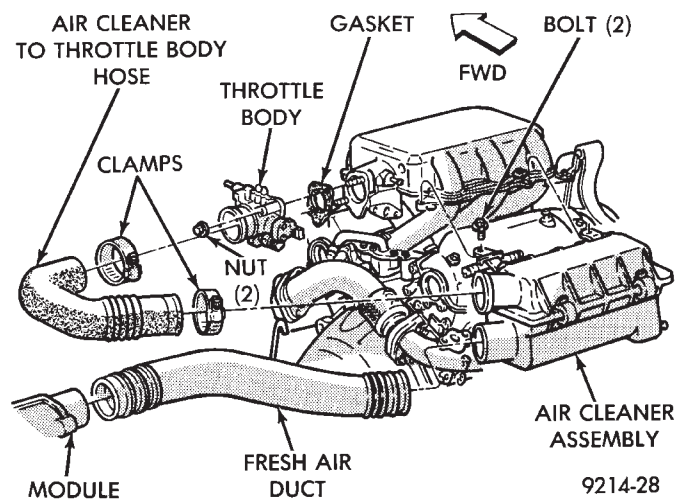

Fig. 3 Throttle Body Assembly 3.0L

INSTALLATION

- (1) Position new intake manifold gaskets on cylinder head and install intake (cross) manifold.
- (2) Install (8) nuts and washers and tighten in several steps in order shown in (Fig. 16) to 20 N•m (174 in. lbs.).
- (3) Make sure the injector holes are clean and all plugs have been removed.
- (4) Lube injector O-ring with a drop of clean engine oil to ease installation.

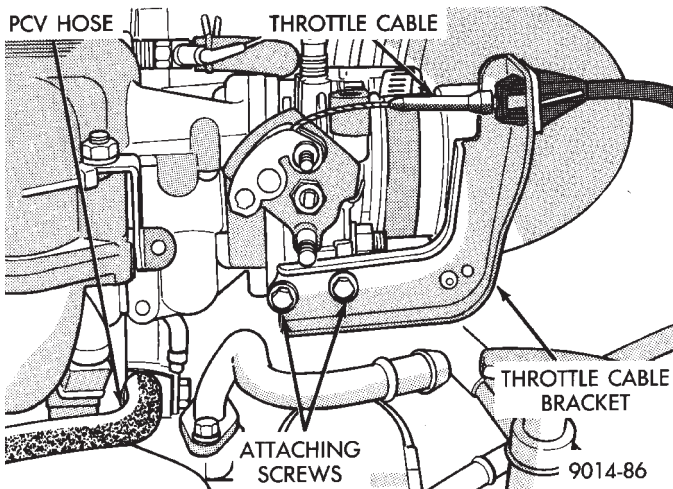

Fig. 4 Throttle Cable Attachment

(5) Put the tip of each injector into their ports. Push the assembly into place until the injectors are seated in the ports.

(6) Install the (3) fuel rail attaching bolts and torque to 13 N•m (115 in. lbs.).

(7) Install fuel pressure regulator onto fuel rail. Install attaching bolts to intake manifold. Torque regulator nuts and bracket bolts to 10 N•m (95 in. lbs.) (Fig. 12).

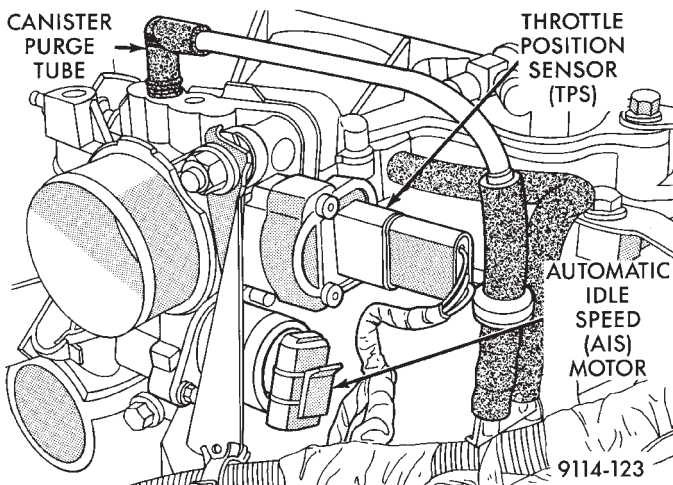

Fig. 5 Electrical and Vacuum Connections to Throttle Body

(8) Install fuel supply and return tube hold-down bolt and the vacuum crossover tube hold-down bolt and torque to 10 N•m (95 in. lbs.).

(9) Connect fuel injector wiring harness to engine wiring harness (Fig. 11).

(10) Connect vacuum harness to fuel pressure regulator and fuel rail assembly (Fig. 10).

(11) Remove covering from lower intake manifold and clean surface.

(12) Place intake manifold gaskets **with beaded sealant side up** on lower manifold. Put air intake in

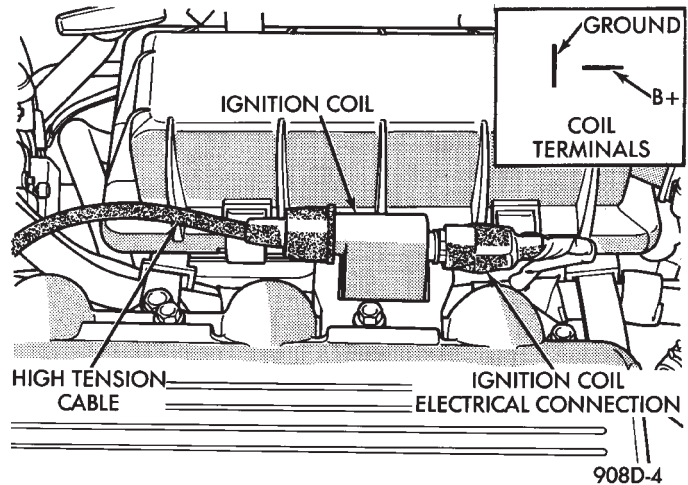

Fig. 6 Ignition Coil Removal

place. Install attaching fasteners (8) and tighten in several steps in sequence shown (Fig. 17) to 13 N•m (115 in. lbs.).

(13) Connect fuel line to fuel rail (Fig. 7). Torque hose clamps to 1 N•m (10 in. lbs.).

(14) Connect vacuum harness to air intake plenum.

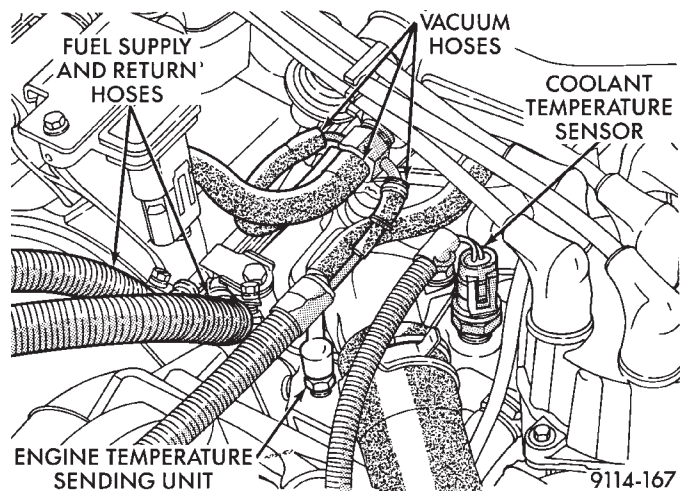

Fig. 7 Coolant Temperature Sensor Electrical Connections

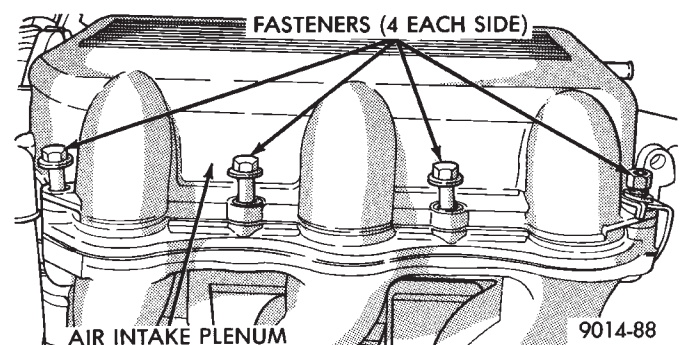

Fig. 8 Air Intake Plenum to Intake Manifold Attaching Bolts

(15) Connect and coolant temperature sensor electrical connector to sensor (Fig. 7).

(16) Connect PCV and brake booster supply hose to intake plenum.

(17) Connect automatic idle speed (AIS) motor and throttle position sensor (TPS) electrical connectors (Fig. 5).

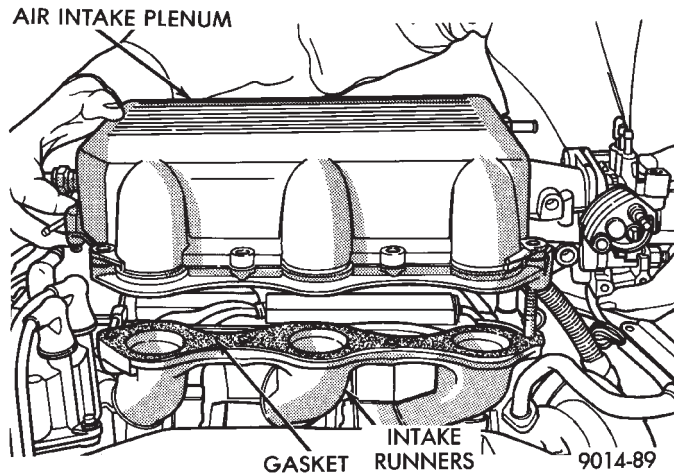

Fig. 9 Removing Air Intake Plenum

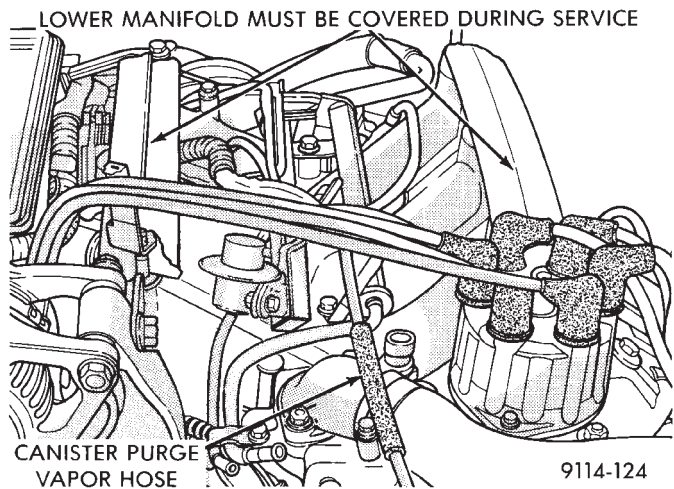

Fig. 10 Vacuum Connections for Fuel Rail and Fuel Pressure Regulator

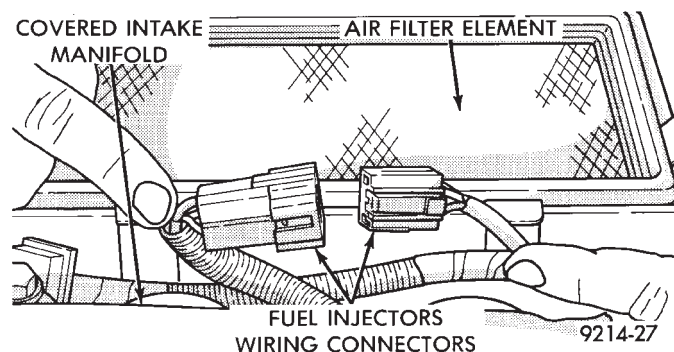

Fig. 11 Fuel Injector Wiring Harness

(18) Connect vacuum vapor harness to throttle body (Fig. 5).

(19) Install throttle cable and transaxle kickdown linkage (Fig. 4).

(20) Install air inlet hose assembly (Fig. 3).

(21) Install radiator to thermostat housing hose and heater hose to heater pipe nipple.

(22) Fill cooling system, see Refilling System in Cooling, Group 7.

(23) Connect negative battery cable.

(24) With the DRB II use ASD Fuel System Test to pressurize system to check for leaks.

CAUTION: When using the ASD Fuel System Test, The Auto Shutdown (ASD) Relay will remain energized for 7 minutes or until the ignition switch is turned to the OFF position, or Stop All Test is selected.

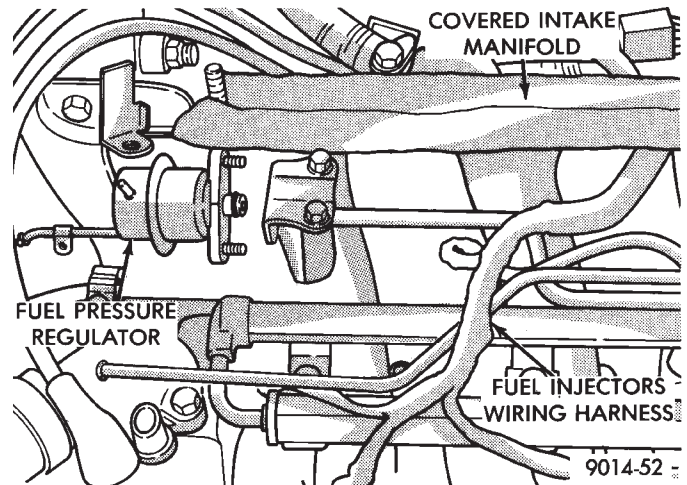

Fig. 12 Fuel Pressure Regulator to Fuel Rail Assembly

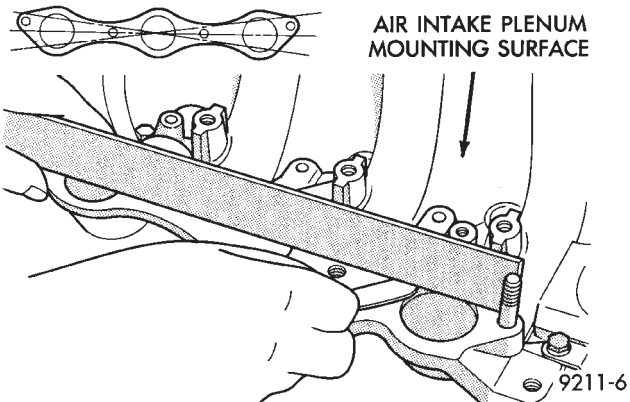
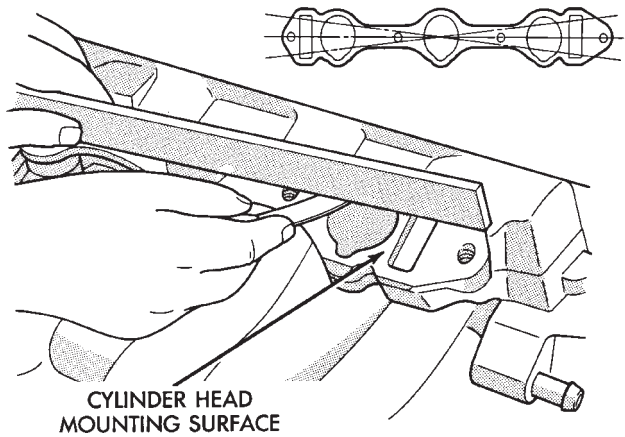

Fig. 13 Check Intake (Cross) Manifold Mounting Surface

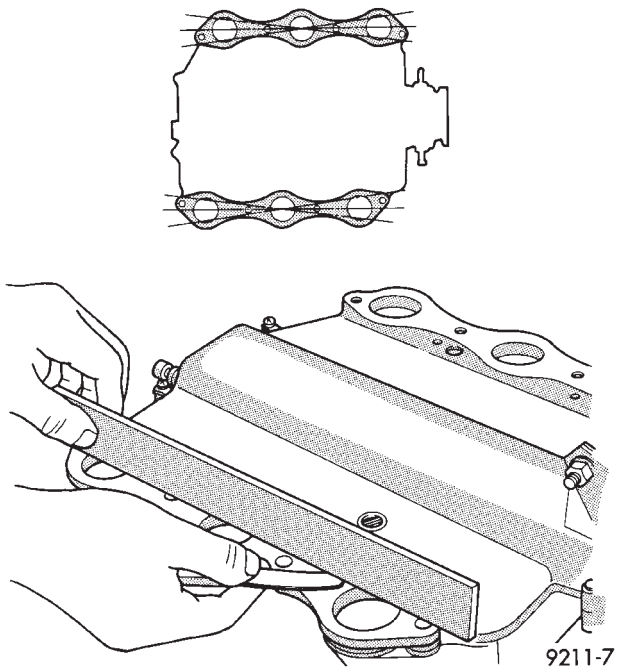
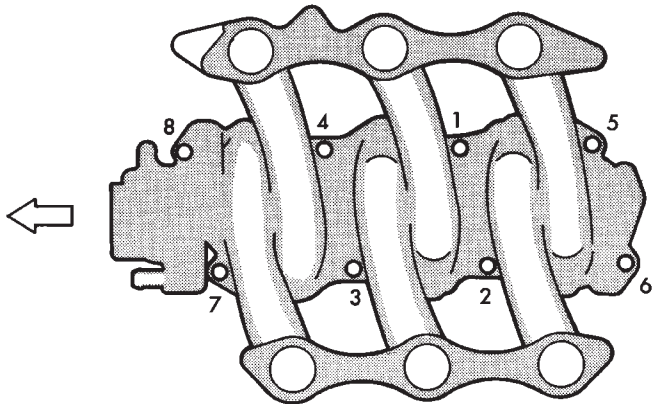

Fig. 14 Check Intake Plenum Mounting Surfaces

<p>Intake Plenum Mounting Surface Standard: .15mm (.004 inch.) Maximum: .30mm (.008 inch.)</p>
<p>Cylinder Head Mounting Surface Standard: .10mm (.003 inch.) Maximum: .20mm (.005 inch.)</p>

9111-11

Fig. 15 Intake Plenum and Cylinder Head Mounting Surface Specifications



RR11B5

Fig. 16 Nut Tightening Sequence for Intake (Cross) Manifold

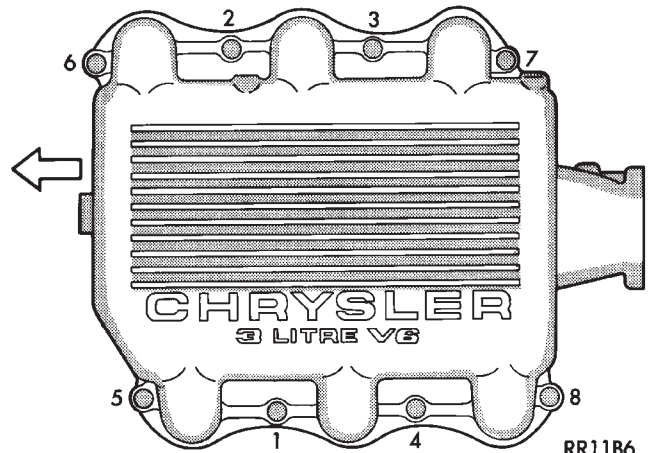

RR11B6

Fig. 17 Intake Plenum Tightening Sequence

EXHAUST MANIFOLDS

REMOVAL

- (1) Raise vehicle and disconnect exhaust pipe from rear (cowl side) exhaust manifold at articulated joint.
- (2) Disconnect Oxygen Sensor lead wire at the rear exhaust manifold (Fig. 18).
- (3) Remove bolts attaching cross-over pipe to manifold (Figs. 2 and 19).
- (4) Remove nuts attaching rear manifold to cylinder head and remove manifold.

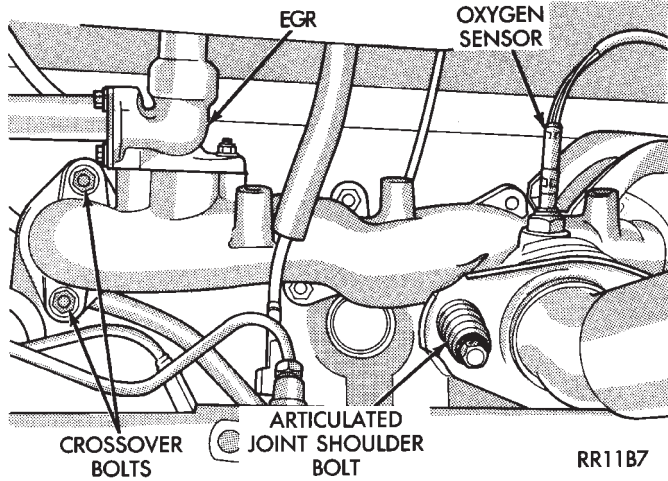

Fig. 18 Separate Articulated Joint, Disconnect Oxygen Sensor Wire

- (5) Lower vehicle and remove screws attaching front heat shield to front manifold (Fig. 2).
- (6) Remove bolts fastening crossover pipe to front exhaust manifold and nuts fastening manifold to cylinder head. Remove assemblies.

INSPECTION

Inspect exhaust manifolds for damage or cracks and check distortion of the cylinder head mounting surface and exhaust crossover mounting surface with a straightedge and thickness gauge (Fig. 20).

INSTALLATION

Install the gaskets with the numbers 1-3-5 embossed on the top on the rear bank and those with numbers 2-4-6 on the front (Radiator side) bank (Fig. 21).

- (1) Install rear exhaust manifold and tighten attaching nuts to 20 N•m (175 in. lbs.).
- (2) Attach exhaust pipe to exhaust manifold and tighten shoulder bolt to 28 N•m (250 in. lbs.)
- (3) Attach crossover pipe to exhaust manifold and tighten bolt to 69 N•m (51 ft. lbs.)
- (4) Connect heated oxygen sensor lead (Fig. 18).
- (5) Install front exhaust manifold and attach exhaust crossover.
- (6) Install front manifold heat shield and tighten attaching screws to 15 N•m (130 in. lbs.) (Fig. 2).

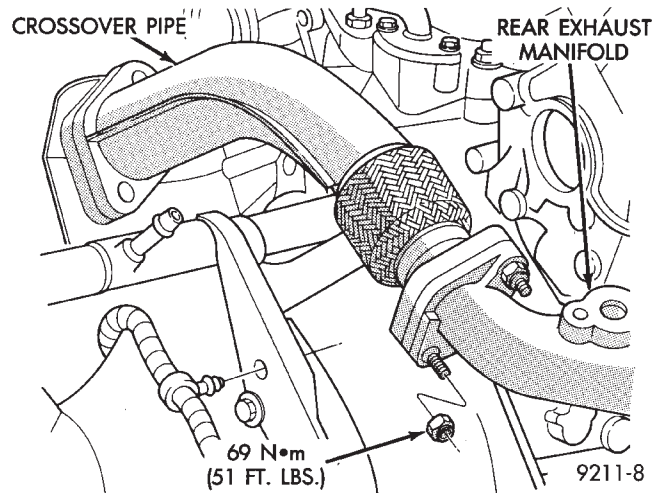

Fig. 19 Crossover Pipe

STANDARD: .15 mm (.004 inch)
LIMIT: .3 mm (.008 inch)

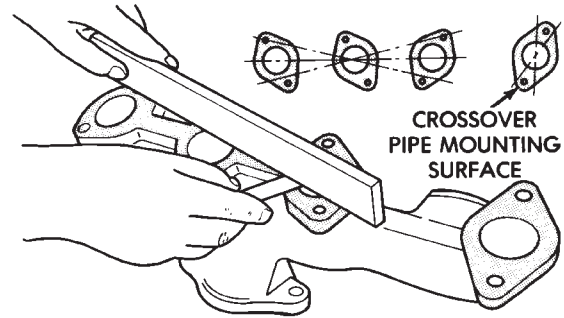

Fig. 20 Check Exhaust Manifold Mounting Surface

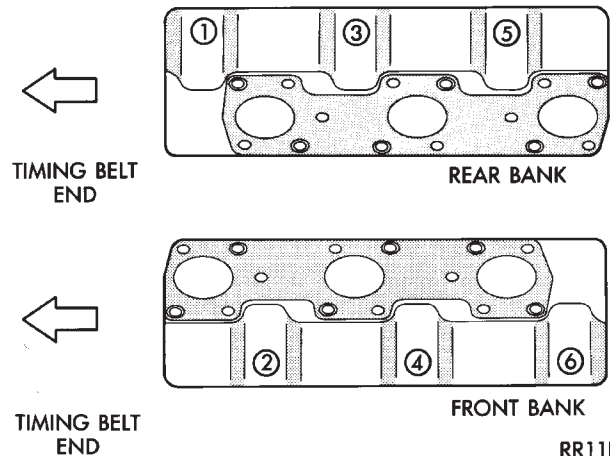

Fig. 21 Identify Exhaust Manifold Gaskets

INTAKE/EXHAUST MANIFOLDS — 3.3L ENGINE

REMOVAL

(1) Perform fuel system pressure release procedure **(before attempting any repairs)**.

(2) Disconnect negative battery cable. Drain cooling system. See Cooling System, Group 7.

FUEL SYSTEM PRESSURE RELEASE PROCEDURE

The MPI fuel system is under a constant pressure of approximately 330 kPa (48 psi). Before servicing the fuel pump, fuel lines, fuel filter, throttle body or fuel injector, the fuel system pressure must be released.

(a) Loosen fuel filler cap to release fuel tank pressure.

(b) Disconnect injector wiring harness from engine harness.

(c) Connect a jumper wire to ground terminal Number 1 of the injector harness (Fig. 1) to engine ground.

(d) Connect a jumper wire to the positive terminal Number 2 of the injector harness (Fig. 1) and touch the battery positive post for no longer than 5 seconds. This releases system pressure.

(e) Remove jumper wires.

(f) Continue fuel system service.

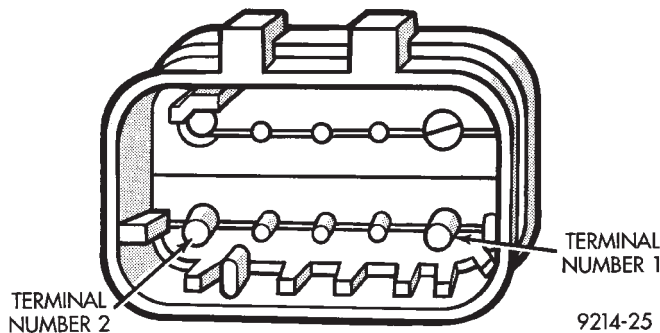

Fig. 1 Injector Harness Connector

(3) Remove air cleaner to throttle body hose assembly (Fig. 2).

(4) Remove throttle cable (Fig. 3). Remove wiring harness from throttle cable bracket.

(5) Remove automatic idle speed (AIS) motor and throttle position sensor (TPS) wiring connectors from throttle body (Fig. 4).

(6) Remove vacuum hose harness from throttle body (Fig. 4).

(7) Remove PCV and brake booster hoses from air intake plenum (Fig. 5).

(8) Remove EGR tube flange from intake plenum (Fig. 5).

(9) Disconnect Charge Temperature Sensor electrical connector. Remove vacuum harness connectors from Intake Plenum (Fig. 5).

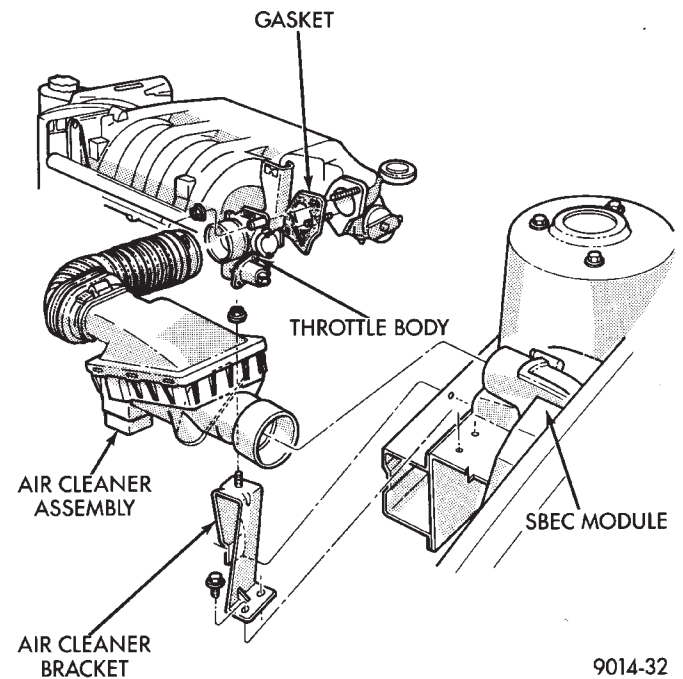

Fig. 2 Throttle Body Assembly 3.3L

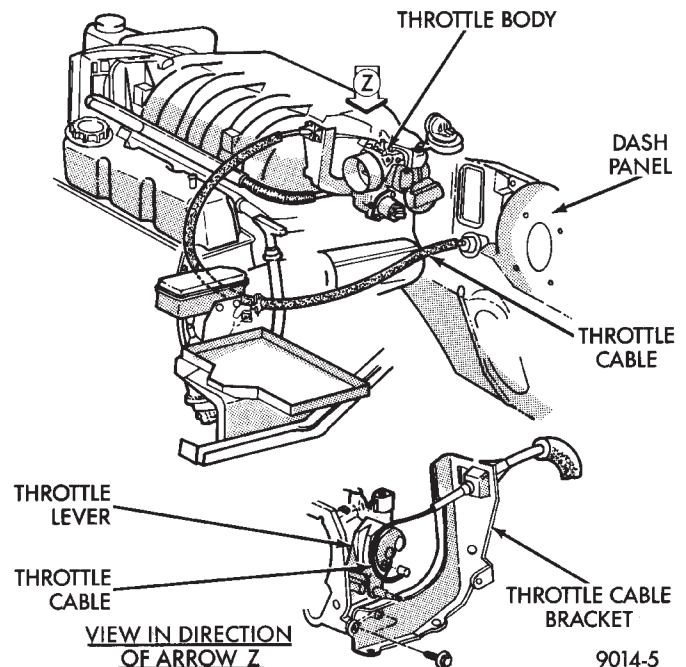

Fig. 3 Throttle Cable Attachment

(10) Remove cylinder head to intake plenum strut (Fig. 5).

(11) Disconnect MAP Sensor and heated Oxygen Sensor electrical connection. Remove the engine mounted ground strap (Fig. 6).

(12) Remove the fuel hose quick connect fittings from the fuel rail by using an open end wrench pushing in on the plastic ring located on the end of the fittings. Gently pull the fittings from the fuel rail (Fig. 7).

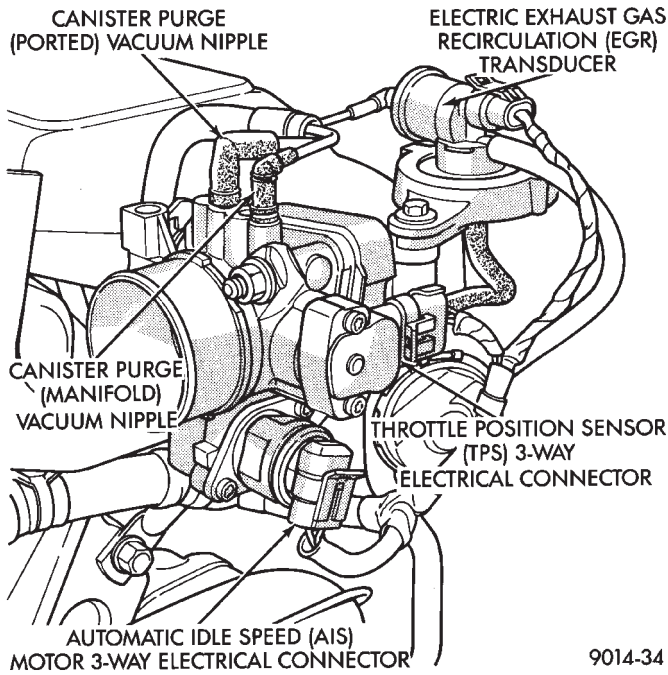

Fig. 4 Electrical and Vacuum Connection to Throttle Body

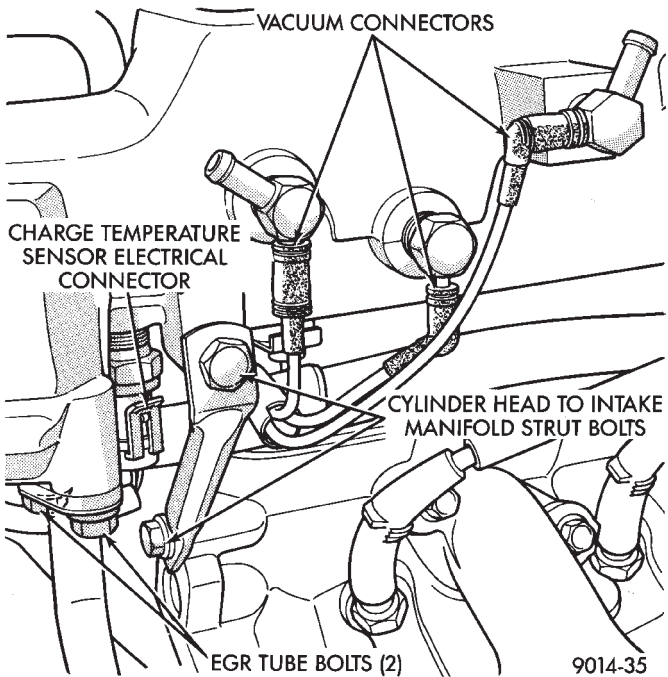

Fig. 5 Electrical and Vacuum Connections To Intake Manifold

WARNING: WRAP A SHOP TOWEL AROUND HOSES TO CATCH ANY GASOLINE SPILLAGE DURING REMOVAL.

(13) Remove direct ignition system (DIS) coils and generator bracket to intake manifold bolt (Fig. 8).

(14) Remove intake manifold bolts and rotate manifold back over rear valve cover (Fig. 9).

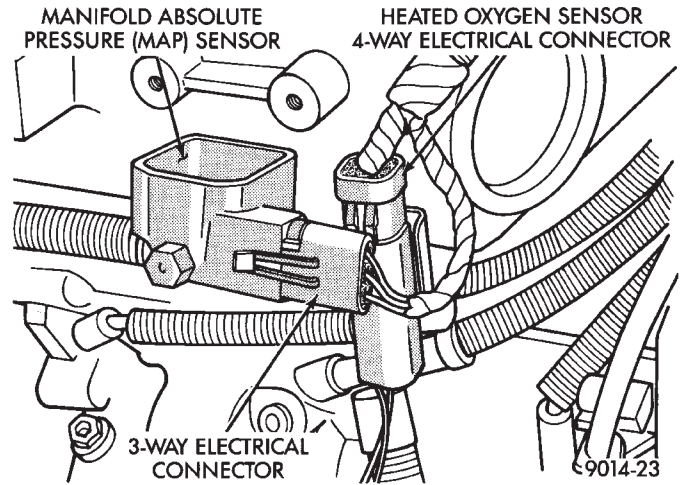

Fig. 6 MAP Sensor Electrical Connector

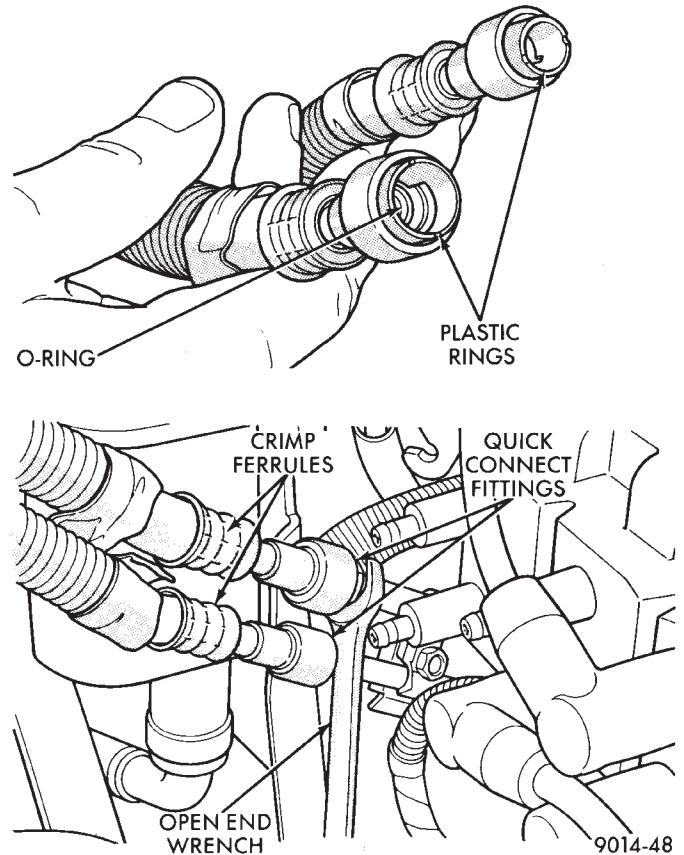

Fig. 7 Quick Connect Fuel Fittings to Fuel Rail

(15) Cover intake manifold with suitable cover when servicing (Fig. 10).

(16) Remove vacuum harness connector from Fuel Pressure Regulator.

(17) Remove fuel tube retainer bracket screw and fuel rail attaching bolts (Fig. 10). Spread the retainer bracket to allow fuel tube removal clearance.

(18) Remove fuel rail injector wiring clip from the generator bracket (Fig. 11).

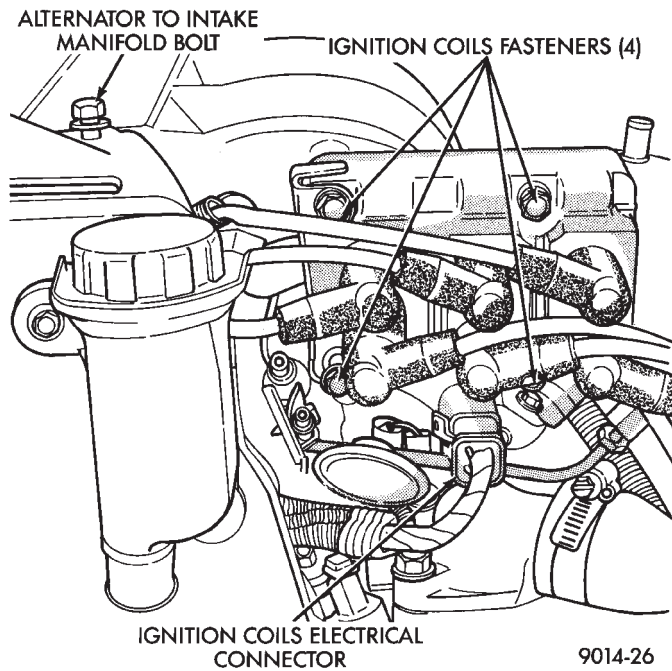

Fig. 8 Ignition Coils

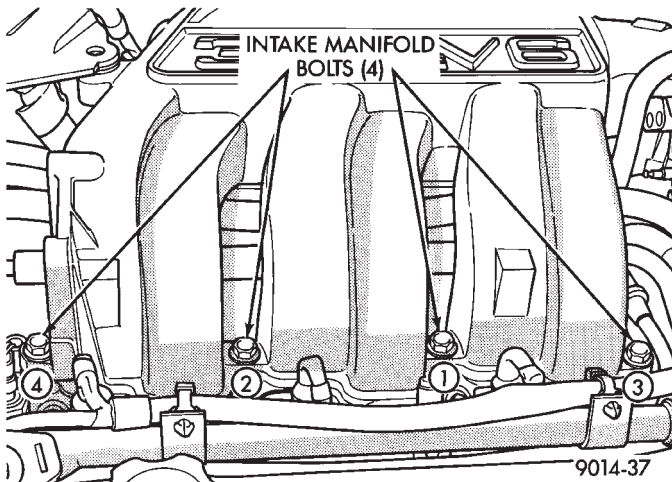

Fig. 9 Intake Manifold Bolts

(19) Disconnect cam sensor, coolant temperature sensor, and engine temperature sensors (Fig. 11).

(20) Remove fuel injector wiring clip from intake manifold water tube.

(21) Remove fuel rail. Be careful not to damage the rubber injector O-rings upon removal from their ports (Fig. 12).

(22) Remove upper radiator hose, bypass hose and rear intake manifold hose (Fig. 13).

(23) Remove intake manifold bolts. Remove intake manifold.

(24) Remove intake manifold seal retainers screws (Fig. 14). Remove intake manifold gasket.

INSPECTION

Check for:

- Damage and cracks of each section.

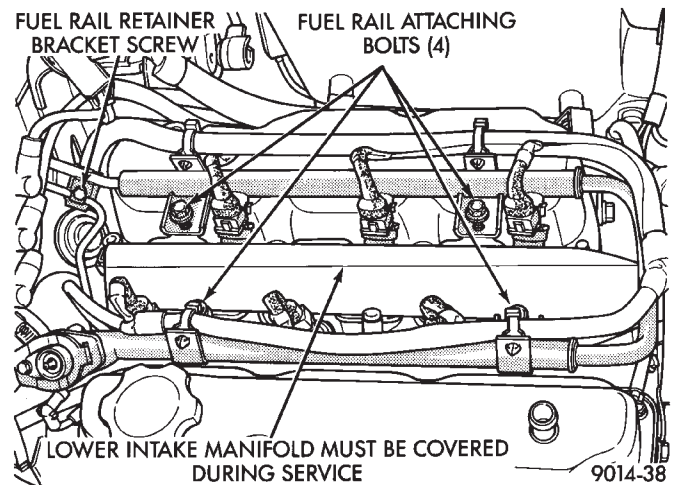

Fig. 10 Fuel Rail Attaching Bolts

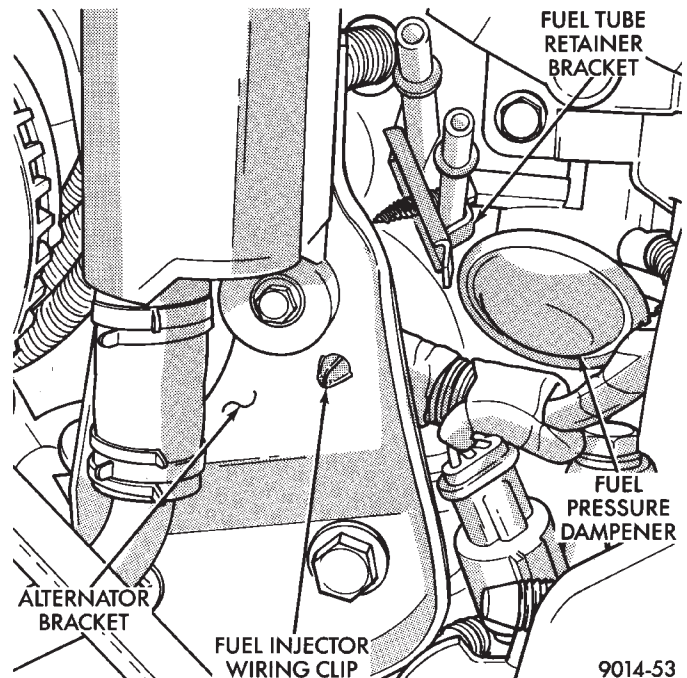

Fig. 11 Fuel Injector Wiring Clip

- Clogged water passages in end crossovers.

INSTALLATION

(1) Clean all surfaces of cylinder block and cylinder heads.

(2) Place a drop (approximately 1/4 in. diameter) of Mopar Silicone Rubber Adhesive Sealant or equivalent, onto each of the **four** manifold to cylinder head gasket corners (Fig. 15).

WARNING: INTAKE MANIFOLD GASKET IS MADE OF VERY THIN METAL AND MAY CAUSE PERSONAL INJURY, HANDLE WITH CARE.

(3) Carefully install the intake manifold gasket (Fig. 14). Torque end seal retainer screws to 12 N•m (105 in. lbs.).

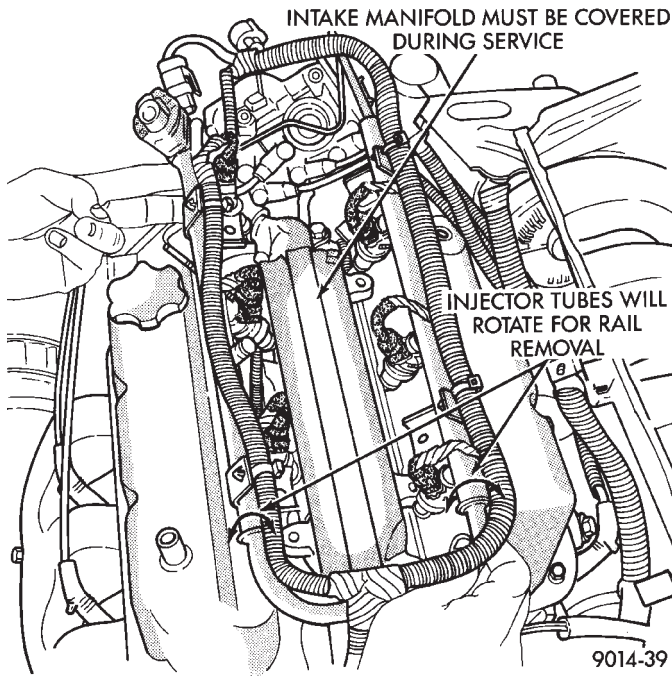

Fig. 12 Fuel Rail Removal

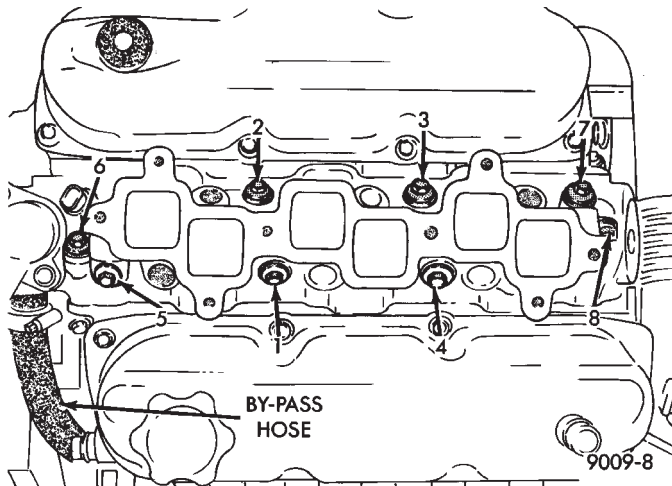

Fig. 13 Intake Manifold Removal and Installation

(4) Install intake manifold and (8) bolts and torque to 1 N•m (10 in. lbs.). Then torque bolts to 22 N•m (200 in. lbs.) in sequence shown in (Fig. 13). Then torque again to 22 N•m (200 in. lbs.). After intake manifold is in place, **inspect to make sure seals are in place.**

(5) Make sure the injector holes are clean and all plugs have been removed.

(6) Lube injector O-ring with a drop of clean engine oil to ease installation.

(7) Put the tip of each injector into their ports. Push the assembly into place until the injectors are seated in the ports (Fig. 12).

(8) Install the (4) fuel rail attaching bolts and torque to 22 N•m (200 in. lbs.) (Fig. 10).

(9) Install fuel tube retaining bracket screw and torque to 4 N•m (35 in. lbs.) (Fig. 10).

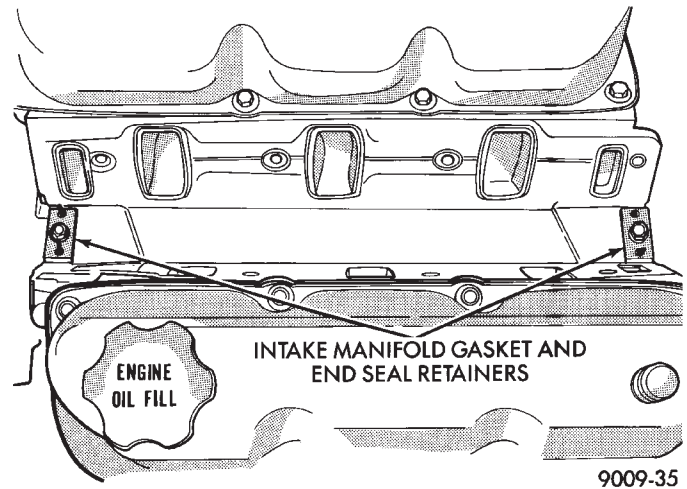

Fig. 14 Intake Manifold Gasket

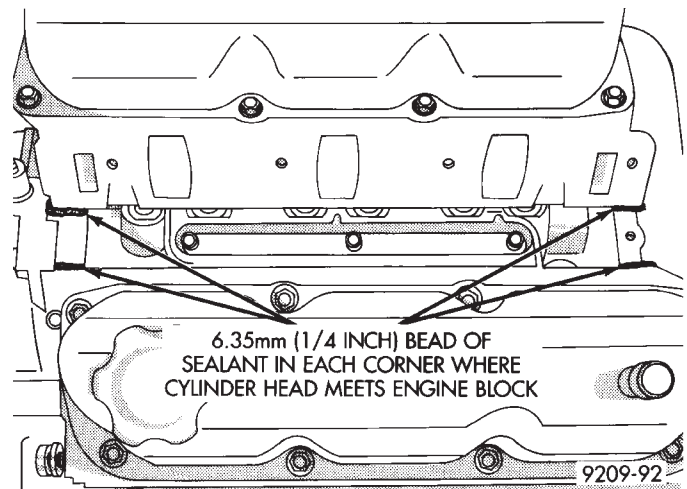

Fig. 15 Intake Manifold Gasket Sealing

(10) Reconnect cam sensor, coolant temperature sensor and engine temperature sensors (Fig. 11).

(11) Install fuel injector harness wiring clips on the generator bracket and intake manifold water tube (Fig. 11).

(12) Connect fuel pressure regulator vacuum line.
 (13) Remove covering on lower intake manifold and clean surface.

(14) Place intake manifold gasket on lower manifold. Put upper manifold into place and install bolts finger tight.

(15) Install the generator bracket to intake manifold bolt and the cylinder head to intake manifold strut bolts. (Do not torque.)

(16) Torque intake manifold bolts to 28 N•m (250 in. lbs.) following torque sequence in (Fig. 9).

(17) Torque generator bracket to intake manifold bolt to 54 N•m (40 ft. lbs.) (Fig. 8).

(18) Torque the cylinder head to intake manifold strut bolts to 54 N•m (40 ft. lbs.) (Fig. 5).

(19) Connect ground strap, MAP and heated oxygen sensor electrical connectors (Fig. 6).

(20) Connect charge temperature sensor electrical connector (Fig. 5).

(21) Connect vacuum harness to intake plenum (Fig. 5).

(22) Using a new gasket, connect the EGR tube flange to the intake manifold and torque to 22 N•m (200 in. lbs.).

(23) Clip wiring harness into the hole in the throttle cable bracket.

(24) Connect the wiring connectors to the throttle position sensor (TPS) and Automatic Idle Speed (AIS) motor (Fig. 4).

(25) Connect vacuum harness to throttle body (Fig. 4).

(26) Install the direct ignition system (DIS) coils. Torque fasteners to 12 N•m (105 in. lbs.) (Fig. 8).

(27) Lubricate the ends of the chassis fuel tubes with 30 wt. oil. Connect fuel supply and return hoses to chassis fuel tube assembly. Pull back on the quick connect fitting to ensure complete insertion (Fig. 7). (Refer to Fuel Hoses, Clamps and Quick Connect Fittings in Group 14 Fuel Systems).

(28) Install throttle cable (Fig. 3).

(29) Connect fuel injector wiring harness.

(30) Install air cleaner and hose assembly (Fig. 2).

(31) Connect negative battery cable. Fill Cooling System. See Cooling System, Group 7.

(32) With the DRB II use ASD Fuel System Test to pressurize system to check for leaks.

CAUTION: When using the ASD Fuel System Test, The Auto Shutdown (ASD) Relay will remain energized for 7 minutes or until the ignition switch is turned to the OFF position, or Stop All Test is selected.

EXHAUST MANIFOLDS

REMOVAL

(1) Raise vehicle and disconnect exhaust pipe from rear (cowl side) exhaust manifold at articulated joint.

(2) Separate EGR tube from rear manifold and disconnect Heated Oxygen Sensor lead wire (Fig. 16).

(3) Remove Generator/Power Steering Support Strut (Fig. 16).

(4) Remove bolts attaching cross-over pipe to manifold (Fig. 16).

(5) Remove bolts attaching rear manifold to cylinder head and remove manifold.

(6) Lower vehicle and remove screws attaching front heat shield to front manifold (Fig. 17).

(7) Remove bolts fastening crossover pipe to front exhaust manifold and nuts fastening manifold to cylinder head. Remove assemblies (Fig. 18).

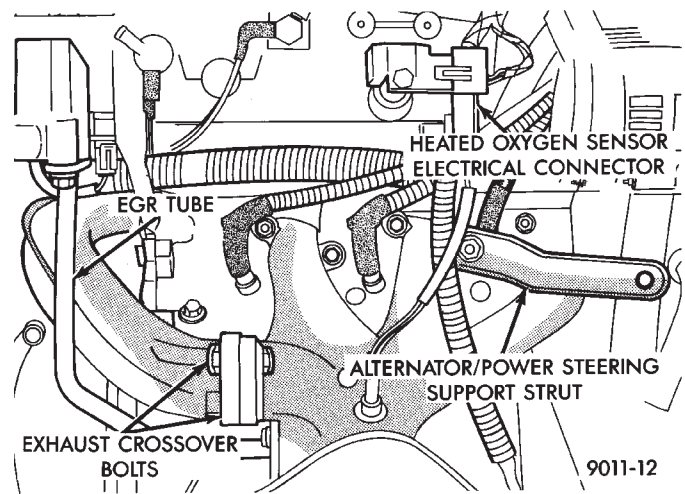

Fig. 16 EGR Tube, Heated Oxygen Sensor and Generator/Power Steering Strut

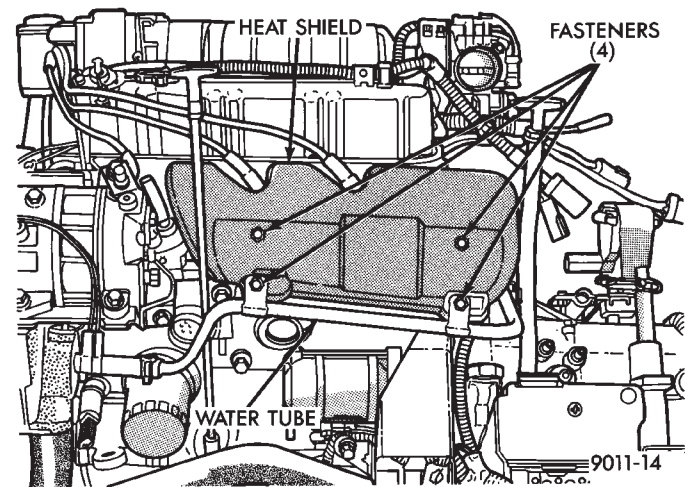

Fig. 17 Heat Shield

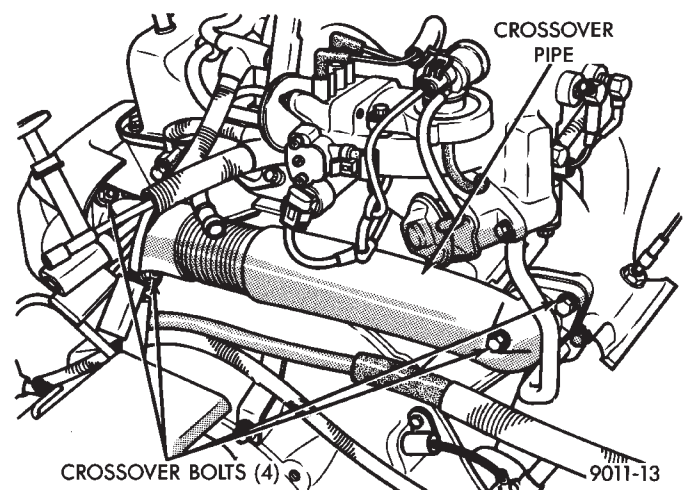

Fig. 18 Crossover Pipe

INSPECTION

Inspect exhaust manifolds for damage or cracks and check distortion of the cylinder head mounting

surface and exhaust crossover mounting surface with a straightedge and thickness gauge (Fig. 19).

STANDARD: .15 mm (.004 inch)
LIMIT: .3 mm (.008 inch)

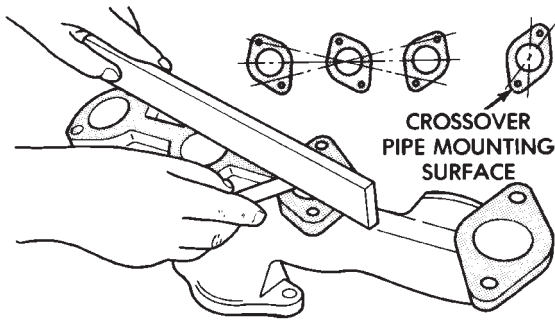

9111-10

Fig. 19 Check Exhaust Manifold Mounting Surface

INSTALLATION

- (1) Install rear exhaust manifold and tighten attaching bolts to 23 N•m (200 in. lbs.).
- (2) Attach exhaust pipe to exhaust manifold and tighten shoulder bolt to 28 N•m (250 in. lbs.).
- (3) Attach crossover pipe to exhaust manifold and tighten bolt to 33 N•m (25 ft. lbs.) and connect oxygen sensor lead (Fig. 16).
- (4) Reinstall EGR Tube and Generator/Power Steering Strut (Fig. 16).
- (5) Install front exhaust manifold and attach exhaust crossover (Fig. 18).
- (6) Install front manifold heat shield and tighten attaching screws to 23 N•m (200 in. lbs.) (Fig. 17).

TORQUE SPECIFICATION

Toe Board Heat Shield Mounting Screws	6 N•m (55 in. lbs.)
Toe Board Heat Shield Mounting Nuts	4 N•m (35 in. lbs.)
Insulator Mounting Bolts	17 N•m (150 in. lbs.)
U-Bolt Nuts & Uni-Clamp Nut	28 N•m (250 in. lbs.)
Intake Manifold Screws—2.5L	23 N•m (200 in. lbs.)
Exhaust Manifold Nuts—2.5L	23 N•m (200 in. lbs.)
Exhaust Flange Nuts	28 N•m (250 in. lbs.)
Air Intake Plenum Screws—3.0L	15 N•m (130 in. lbs.)
Intake (Cross) Manifold—3.0L	20 N•m (174 in. lbs.)
Exhaust Manifold Nuts—3.0L	22 N•m (191 in. lbs.)
Exhaust Manifold Heat Shield Screws—3.0L	15 N•m (130 in. lbs.)
Crossover Bolt—3.0L	69 N•m (51 ft. lbs.)
Exhaust Manifold Mounting Stud 3.3L	23 N•m (200 in. lbs.)
Exhaust Manifold Mounting Screws 3.3L	23 N•m (200 in. lbs.)
Exhaust Manifold Crossover Bolts 3.3L	33 N•m (25 ft. lbs.)
Exhaust Manifold Crossover Nuts 3.3L	33 N•m (25 ft. lbs.)
Heat Shield Mounting Screws	4 N•m (35 in. lbs.)
Intake Manifold Attaching Screws 3.3L	23 N•m (200 in. lbs.)
Intake Manifold Upper/Lower Attaching Screws	28 N•m (250 in. lbs.)
Intake Manifold to Cylinder Head Strut 3.3L	54 N•m (40 ft. lbs.)
Intake Manifold Gasket Retainer Screws 3.3L	12 N•m (105 in. lbs.)

9311-44

