

REAR SUSPENSION AND DRIVELINE

CONTENTS

	page		page
ALL WHEEL DRIVE REAR SUSPENSION	5	REAR DRIVE LINE MODULE VACUUM	
REAR DRIVE LINE MODULE ASSEMBLY		ACTUATION DIAGNOSIS	37
(ALL WHEEL DRIVE)	9	SPECIFICATIONS	42
REAR DRIVE LINE MODULE ASSEMBLY		TWO WHEEL DRIVE REAR SUSPENSION	1
SERVICE PROCEDURES	11		

TWO WHEEL DRIVE REAR SUSPENSION

INDEX

	page		page
General Information	1	Rear Sway Bar	4
Rear Shock Absorbers	2	Rear Wheel Alignment—Front Wheel Drive	
Rear Springs	1	Van/Wagons Only	2

GENERAL INFORMATION

The rear suspension on these vehicles include leaf springs and a **tube and casting axle**. It is designed to handle various load requirements.

The shackle angles provide increasing suspension rates as the vehicle is loaded. This provides a comfortable unloaded ride and also ample suspension travel when the vehicle is loaded.

The rear shock absorbers are mounted at an angle, parallel to the springs and forward at the top. This design provides greater stability in addition to controlling ride motion.

CAUTION: The installation of aftermarket load leveling devices is prohibited on these models. Adjustable air shocks or helper springs will cause the rear brake height sensing proportioning valve to sense a light load condition. The loaded condition is being supported by add-on devices. See Brakes Group 5 of this manual for detailed information on the rear brake height sensing proportioning valve.

REAR SPRINGS

REMOVAL

- (1) Raise vehicle on frame contact hoist to a comfortable working position.
- (2) Using floor stands under the axle assembly, raise axle assembly to relieve weight on rear springs.

(3) Disconnect the actuator assembly for height sensing proportioning valve (Fig. 1). Disconnect lower ends of rear shock absorbers at axle brackets.

(4) Loosen and remove “U” bolt nuts and washers, remove “U” bolts.

(5) Lower rear axle assembly, permitting rear springs to hang free.

(6) Loosen and remove four bolts from front spring hanger.

(7) Loosen and remove rear spring shackle nuts and plate, remove shackle from spring.

(8) Loosen and remove front pivot bolt from front spring hanger.

INSTALLATION

(1) Assemble shackle, bushings and plate on rear of spring and rear spring hanger, start shackle bolt nuts. Do not tighten.

(2) Assemble front spring hanger to front of spring eye and install pivot bolt and nut. Do not tighten.

CAUTION: Pivot bolt must face inboard to prevent structural damage during installation of spring.

(3) Raise front of spring and install four hanger bolts, tighten to 61 N•m (45 ft. lbs.) torque. Connect actuator assembly for height sensing proportioning valve.

(4) Raise axle assembly into correct position with axle centered under spring center bolt.

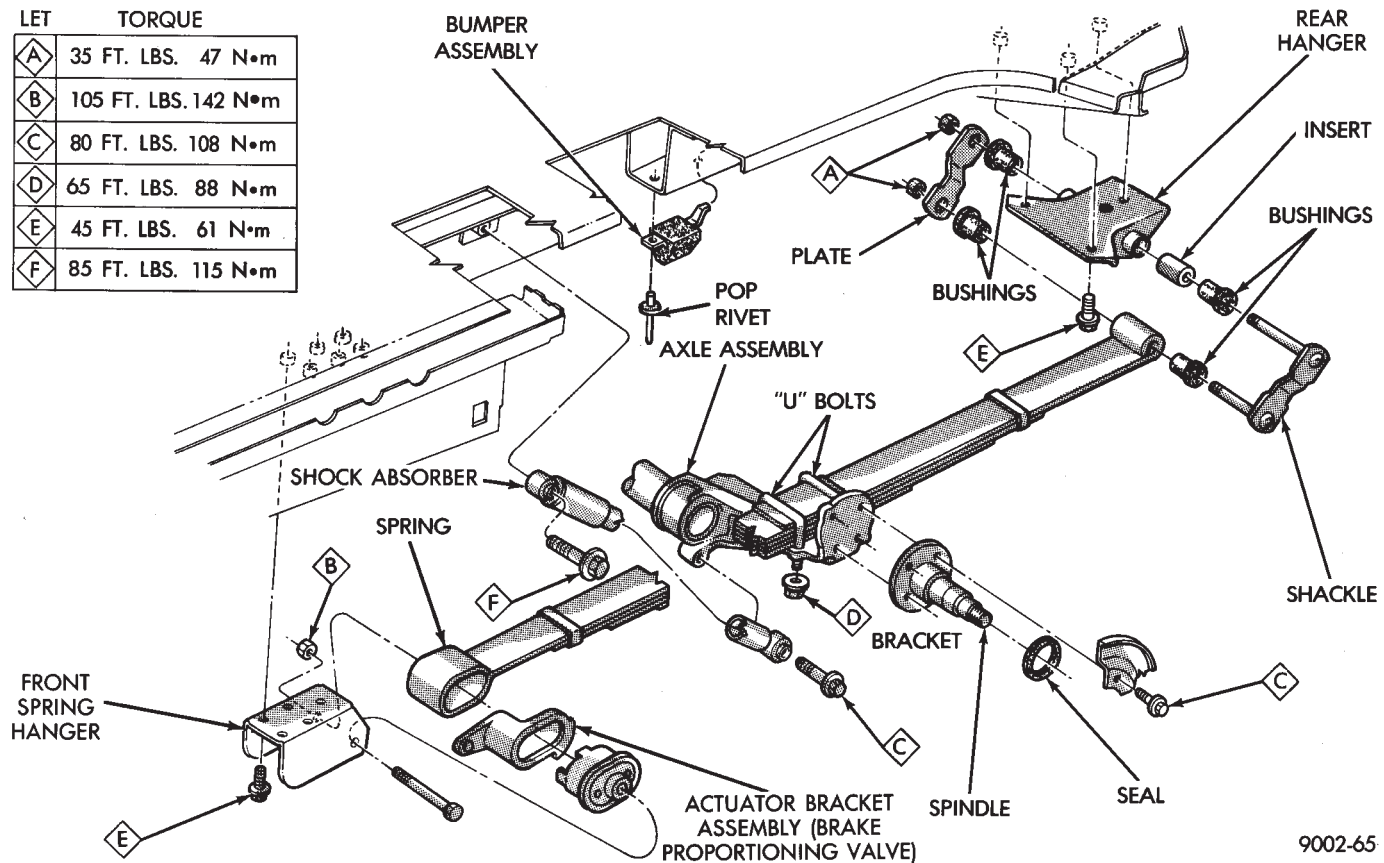

Fig. 1 Rear Suspension

(5) Install "U" bolts, nuts and washers. Tighten "U" bolt nuts to 81 N•m (60 ft. lbs.) torque.

(6) Install shock absorbers and start bolts.

(7) Lower vehicle to floor and with full weight of vehicle on wheels, tighten component fasteners as follows:

- Front pivot bolt — 142 N•m (105 ft. lbs.)
- Shackle nuts — 47 N•m (35 ft. lbs.)
- Shock absorber bolts:
Upper — 115 N•m (85 ft. lbs.)
Lower — 108 N•m (80 ft. lbs.)

(8) Raise vehicle and connect rear brake proportioning valve spring and adjust. Refer to Adjusting Procedure in the Brake Section of this manual.

REAR SHOCK ABSORBERS

REMOVAL AND INSTALLATION

- (1) Lift vehicle on a frame contact hoist.
- (2) Support axle with a jack stand.
- (3) Remove lower shock bolt.
- (4) While holding shock, remove upper shock bolt.
- (5) To Install, Reverse Removal Procedure.

REAR WHEEL ALIGNMENT—FRONT WHEEL DRIVE VAN/WAGONS ONLY

Alignment adjustment if required, is made by adding 0.010 shims between the spindle mounting sur-

face and axle casting. Each shim equals wheel change by $.3^\circ$, as shown in figures 3 through 6. These shims are to be used on two wheel drive vehicles only.

If rear wheel alignment is required, place vehicle on alignment rack and check alignment specifications. **When recording rear toe-in (vehicle backed onto alignment rack) REMEMBER to reverse sign convention; a total toe-in on direct reading charts is actually toe-out while driving.** Maintain rear alignment within Chrysler Corporation recommendations found in Specifications.

INSTALLATION OF REAR ALIGNMENT SHIMS

- (1) Block front tires so vehicle will not move.
- (2) Release parking brake.
- (3) Hoist vehicle so that rear suspension is in full rebound and tires are off the ground. See Hoisting in Lubrication and Maintenance, Group 0.
- (4) Remove wheel and tire assembly.
- (5) Pry off grease cap.
- (6) Remove cotter pin and castle lock.
- (7) Remove adjusting nut.
- (8) Remove brake drum (Fig. 2).
- (9) Loosen four (4) brake assembly and spindle mounting bolts enough to allow clearance for shim installation (Fig. 3). **Do not remove mounting bolts.**

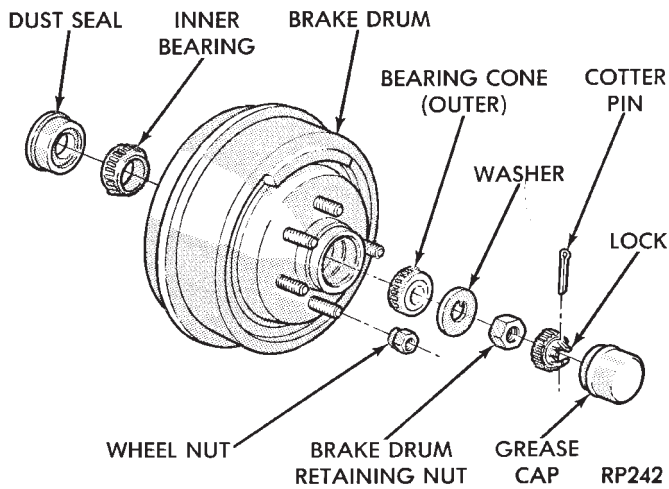

Fig. 2 Remove Brake Drum

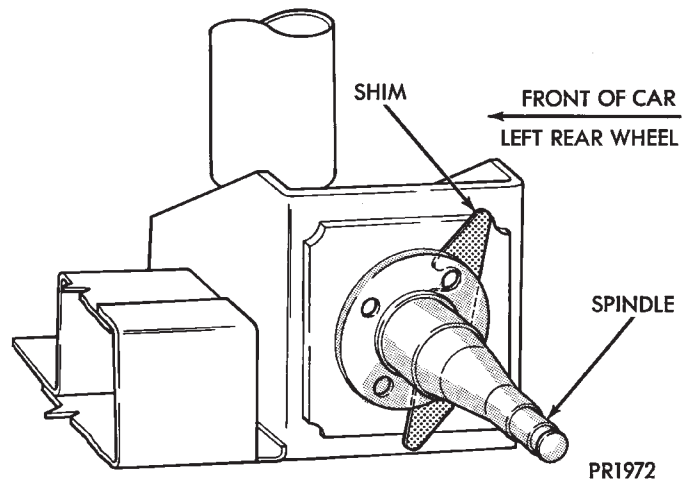

Fig. 5 Shim Installation for Toe-In (typical)

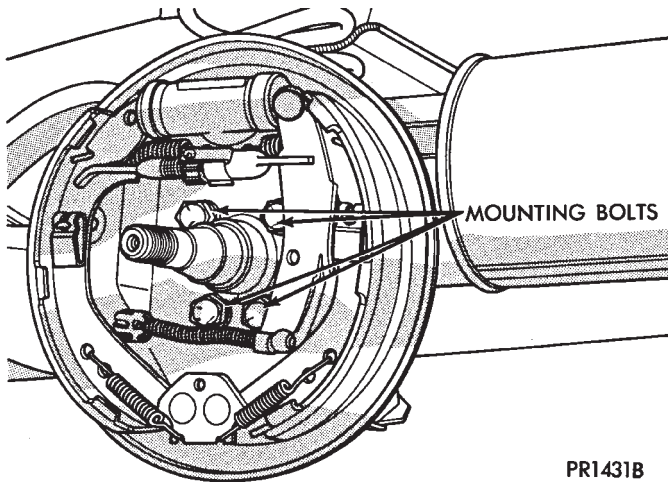

Fig. 3 Loosen Mounting Bolts

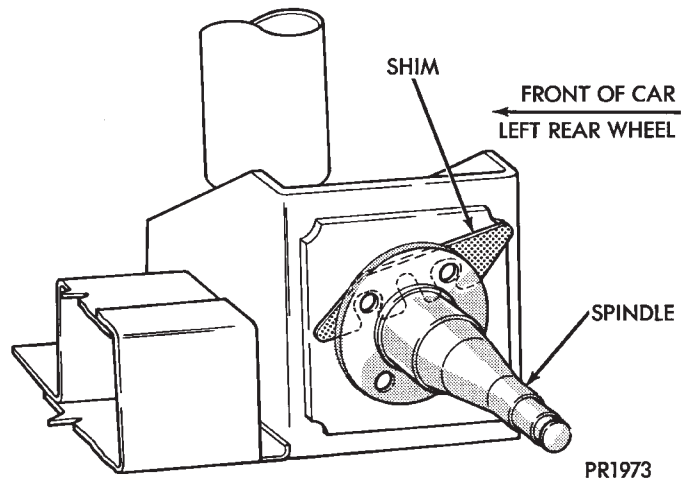

Fig. 6 Shim Installation for Positive Camber (typical)

(10) Install shims as shown in Figs. 4, 5, 6 and 7 for desired wheel change. No more than two shims on each spindle should be used to bring alignment within acceptable range.

Wheel change by .3° per shim.

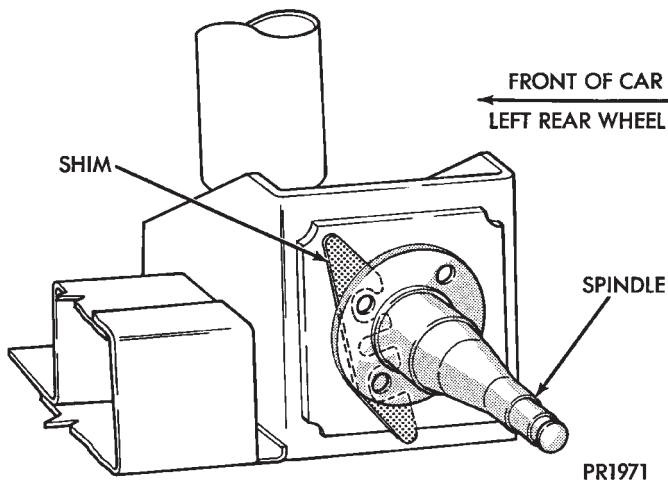

Fig. 4 Shim Installation for Toe-Out (typical)

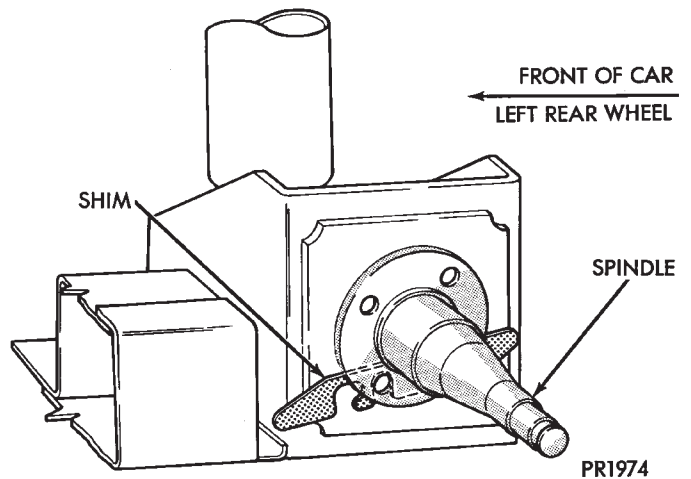

Fig. 7 Shim Installation for Negative Camber (typical)

(11) Tighten four (4) brake assembly and spindle mounting bolts. Tighten to 108 N•m (80 ft. lbs.) torque.

(12) Install brake drum.

(13) Install washer and nut. Tighten adjusting nut to 27-34 N•m (240-300 in. lbs.) torque while rotating wheel. Back off adjusting nut with wrench to completely release bearing preload. Finger tighten adjusting nut.

(14) Position nut lock with one pair of slots in-line with cotter pin hole. Install cotter pin. The end play should be 0.025-0.076 mm (0.001-0.003 inch). Clean and install grease cap.

(15) Install wheel and tire assembly. Tighten wheel nut to 129 N•m (95 ft. lbs.) torque.

(16) Lower vehicle.

(17) Check alignment specifications.

REAR SWAY BAR

The sway bar interconnects both sides of the rear axle and attaches to the rear frame rails using 2 rubber isolated link arms.

Jounce and rebound movements affecting one wheel are partially transmitted to the opposite wheel to reduce body roll.

Attachment to the rear axle tube, and rear frame rails is through rubber-isolated bushings. All parts are serviceable, and the sway bar to axle bushings are split for easy removal and installation. The split in the bushing should be positioned up when installed on the vehicle.

The 2 rubber isolated link arms are connected to the rear frame rails by brackets. These brackets are bolted to the bottom of the frame rails (Fig. 8).

REMOVAL

(1) Raise and support the vehicle. See Hoisting in Lubrication and Maintenance, Group 0.

(2) Remove the 2 lower bolts which hold the sway bar to the link arm on each side of the vehicle (Fig. 2).

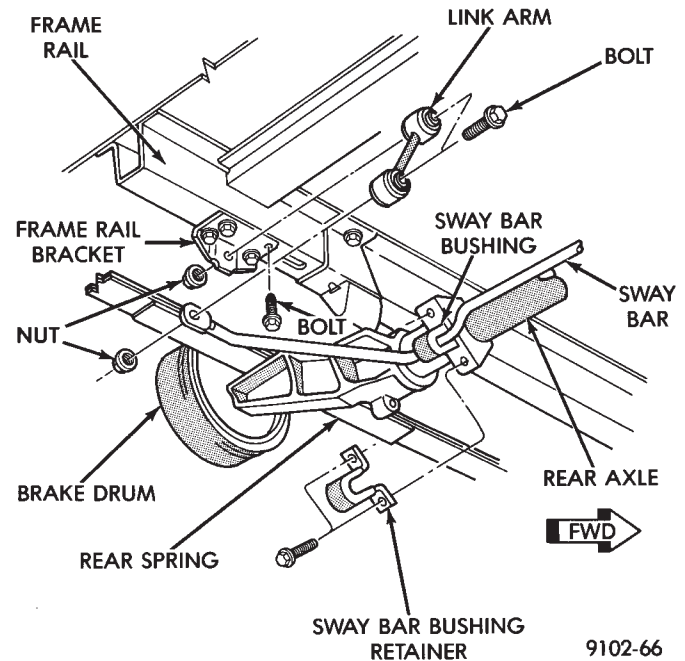

Fig. 9 Rear Sway Bar Remove and Replace

(3) Loosen but do not fully remove the four bolts that attach the sway bar bushing retainers to the rear axle tube brackets.

(4) While holding the sway bar in place. Fully remove the 4 bolts loosened in step 3.

(5) Remove sway bar from vehicle.

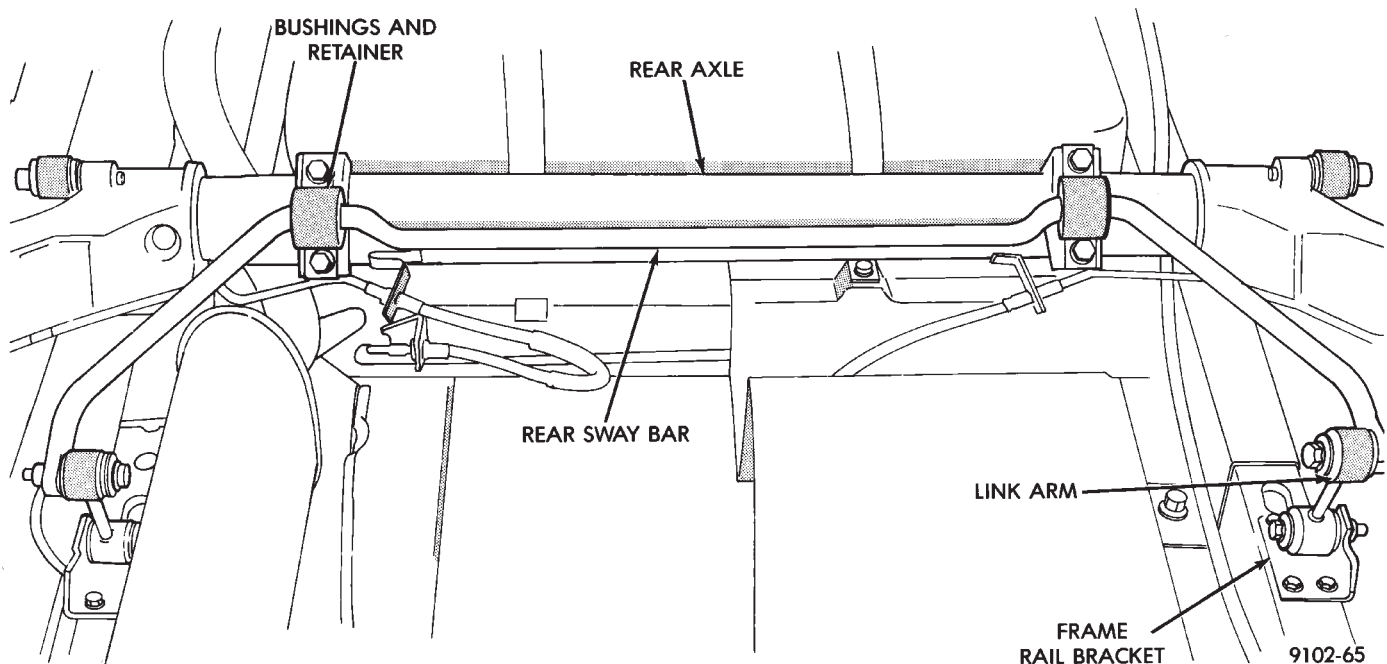

Fig. 8 Rear Sway Bar

(6) If the link arms need to be serviced, remove the upper link arm to bracket bolt. Then remove link arm from frame rail attaching bracket.

INSPECTION

Inspect for broken or distorted clamps, retainers, and bushings. If bushing replacement is required, the sway bar to axle bushing can be removed by opening the split.

(1) Install the link arms onto the frame rail brackets. **DO NOT TIGHTEN.**

(2) Position the axle to sway bar bushing on the sway bar with the slit in the bushing facing up.

(3) Lift the bar assembly onto the rear axle and install the retainers and four bolts. **DO NOT TIGHTEN.**

(4) Install the two lower link arm bolts to the sway bar. **DO NOT TIGHTEN.**

(5) Lower the vehicle so the weight of the vehicle is on all four tires. With the vehicle at its curb height, tighten all attaching bolts to the proper torque listed below.

- Bushing to axle bracket Bolts 61 N•m (45 ft. lbs.)
- Link arm to frame rail bracket 61 N•m (45 ft. lbs.)
- Sway Bar to Link Arm 61 N•m (45 ft. lbs.)
- Frame Rail Bracket to Frame Rail 33 N•m (290 in. lbs.)

For the fastener locations referring to the torques listed above see figures 1 and 2.

ALL WHEEL DRIVE REAR SUSPENSION

INDEX

	page		page
General Information	5	Rear Springs	7
Jounce Bumper	8	Rear Wheel Bearings	5
Rear Shock Absorbers	8		

GENERAL INFORMATION

The rear suspension on these vehicles include leaf springs and a **tube and casting axle**. It is designed to handle various load requirements.

The shackle angles provide increasing suspension rates as the vehicle is loaded. This provides a comfortable unloaded ride and also ample suspension travel when the vehicle is loaded.

The rear shock absorbers are mounted at an angle, parallel to the springs and forward at the top. This design provides greater stability in addition to controlling ride motion.

CAUTION: The installation of aftermarket load leveling devices is prohibited on these models. Adjustable air shocks or helper springs will cause the rear brake height sensing proportioning valve to sense a light load condition. The loaded condition is being supported by add-on devices. See Brakes Group 5 of this manual for detailed information on the rear brake height sensing proportioning valve.

REAR WHEEL BEARINGS

The rear wheel bearings used in the All Wheel Drive system are similar to the bearings used in the

front wheels. The bearings are permanently sealed and require no maintenance. The bearing and hub are serviced as an assembly.

Defective or damaged rear wheel bearings produce a vibration or growl noise. The noise will continue after the transmission is shifted to **NEUTRAL** and the vehicle is coasting.

To tell the difference between rear wheel bearing noise and differential gear noise, road test the vehicle on a smooth road. With traffic permitting, swerve the vehicle sharply right-to-left. If the noise is caused by a rear wheel bearing, it will usually increase in loudness when the vehicle is swerved.

REMOVAL

- (1) Raise vehicle on hoist.
- (2) Remove wheel and tire assembly.

WARNING: DUST INSIDE OF BRAKE DRUM MAY CONTAIN ASBESTOS FIBERS. BREATHING ASBESTOS FIBERS CAN CAUSE SERIOUS BODILY HARM, SUCH AS ASBESTOSIS OR CANCER. EXTREME CARE SHOULD BE TAKEN WHILE SERVICING BRAKE ASSEMBLIES OR COMPONENTS.

(3) Remove brake drum (Fig. 1).

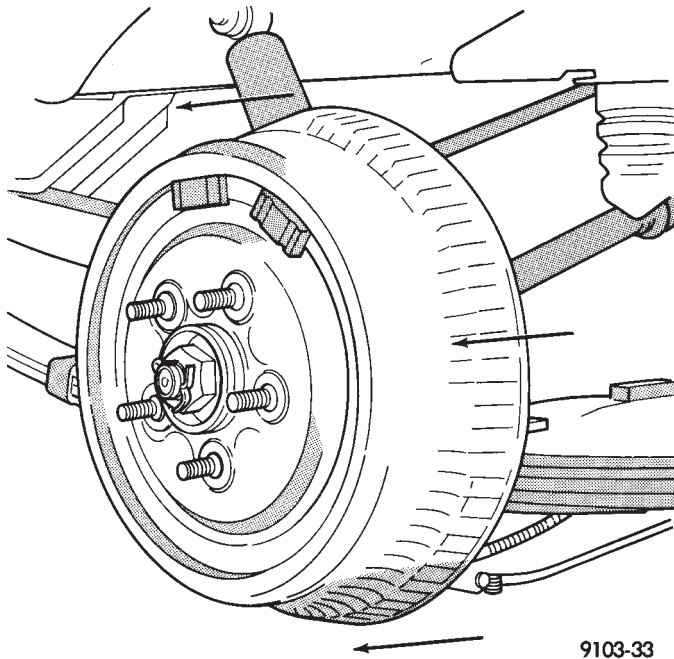

Fig. 1 Remove Rear Drum

(4) Remove cotter pin, nut lock, spring washer and hub nut (Fig. 2).

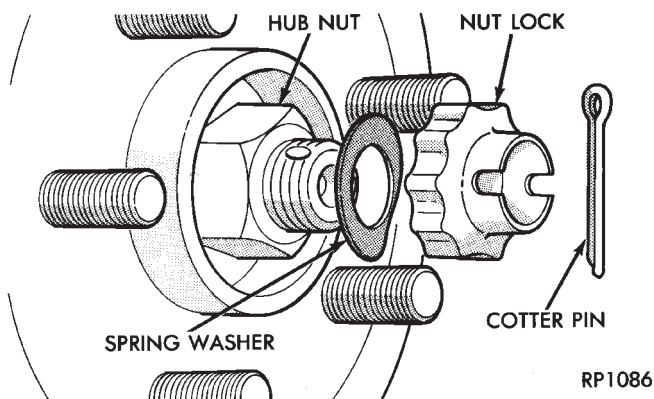

Fig. 2 Hub Nut Assembly

(5) Remove half shaft flange retaining bolts (Fig. 3).

(6) The half shaft is spring loaded. Compress inner half shaft joint slightly and pull downward to clear rear carrier output shaft. Then pull half shaft assembly inboard to remove (Fig. 4).

CAUTION: The half shaft, when installed, acts as a bolt and secures the hub/bearing assembly. If the vehicle is to be supported or moved on its wheels, install and torque a bolt through the hub. This will insure that the hub/bearing assembly cannot loosen.

(7) Remove wheel bearing mounting bolts (Fig 5).

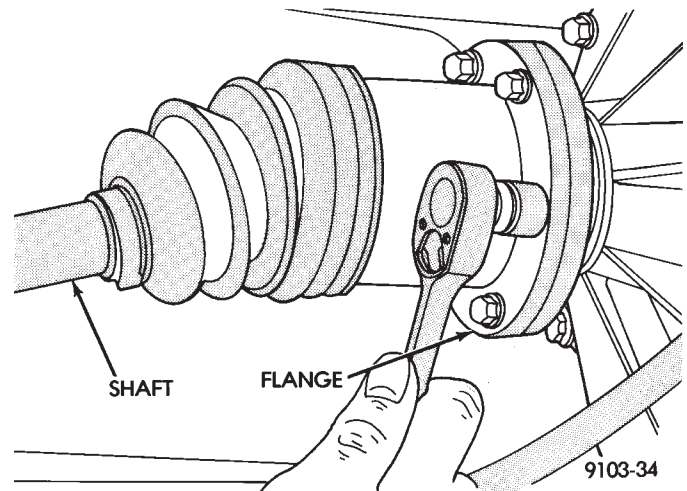

Fig. 3 Half Shaft Flange Retaining Bolts

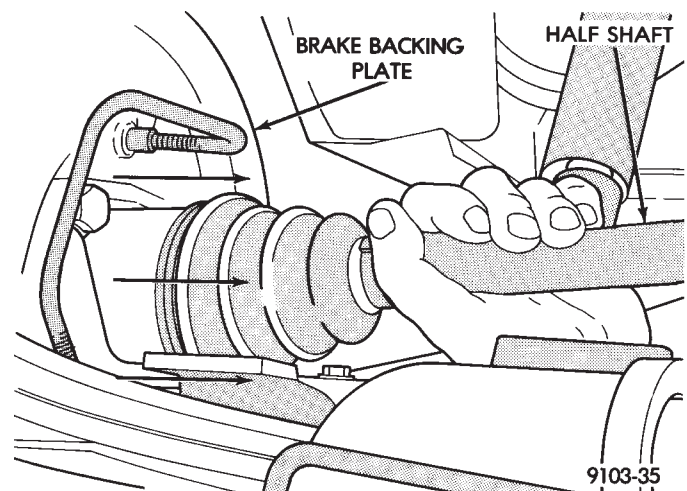

Fig. 4 Half Shaft Removal

(8) Remove wheel bearing and hub assembly (Fig 6).

(9) **Replacement of the grease seal is recommended whenever this service is performed.**

INSTALLATION

(1) Install new hub and bearing assembly and tighten screws in a criss-cross pattern to 130 N•m (96 ft. lbs.).

CAUTION: Knuckle and bearing mounting surfaces must be smooth and completely free of foreign material or nicks.

(2) Use special tool No. 6536-A To install seal if seal replacement is required.

CAUTION: During any service procedures where knuckle and half shaft are separated, thoroughly clean seal and wear sleeve and lubricate BOTH components.

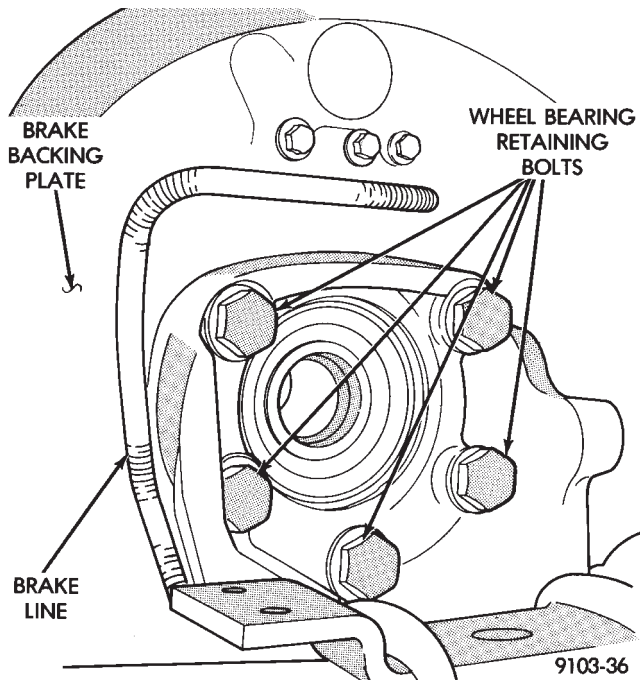

Fig. 5 Wheel Bearing Mounting Bolts

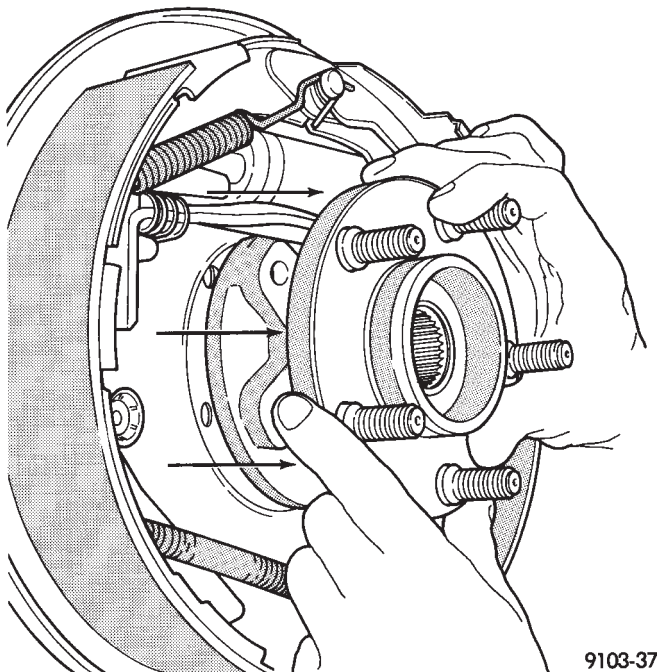

Fig. 6 Pull Wheel Bearing Assembly from Housing

(3) Lubricate the FULL circumference of the seal (and wear sleeve) with MOPAR® Multi-Purpose Lubricant, or equivalent.

(4) Install washer and hub nut after cleaning foreign matter from threads.

(5) With brakes applied, tighten nut to 244 N•m (180 ft. lbs.).

(6) Install spring washer, nut lock and new cotter pin. Wrap cotter pin prongs tightly around nut lock.

(7) Install wheel and tire assembly. Tighten wheel nuts to 115 N•m (85 ft. lbs.).

REAR SPRINGS

REMOVAL

(1) Raise vehicle on frame contact hoist to a comfortable working position.

(2) Using floor stands under the axle assembly, raise axle assembly to relieve weight on rear springs.

(3) Disconnect the actuator assembly for height sensing proportioning valve. Disconnect lower ends of rear shock absorbers at axle brackets.

(4) Loosen and remove "U" bolt nuts and washers, remove "U" bolts.

(5) Lower rear axle assembly, permitting rear springs to hang free.

(6) Loosen and remove four bolts from front spring hanger.

(7) Loosen and remove rear spring shackle nuts and plate, remove shackle from spring.

(8) Loosen and remove front pivot bolt from front spring hanger.

(9) Separate the rear shackle plate, from the shackle and pin assembly. Remove the shackle and pin assembly from the spring.

(10) Loosen and remove front pivot bolt from front spring hanger (Fig. 7).

INSTALLATION

(1) Assemble shackle and pin assembly, bushings and shackle plate on rear of spring and rear spring hanger. Start shackle bolt nuts. Do not tighten.

(2) Assemble front spring hanger to front of spring eye and install pivot bolt and nut. Do not tighten.

CAUTION: Pivot bolt must face inboard to prevent structural damage during installation of spring.

(3) Raise front of spring and install four hanger bolts, tighten to 61 N•m (45 ft. lbs.) torque. Connect actuator assembly for height sensing proportioning valve.

(4) Raise axle assembly into correct position with axle centered under spring center bolt.

(5) Install "U" bolts, nuts and washers. Tighten "U" bolt nuts to 88 N•m (65 ft. lbs.) torque.

(6) Install shock absorbers and start bolts.

(7) Lower vehicle to floor and with full weight of vehicle on wheels, tighten component fasteners as follows:

CAUTION:The following sequence must be followed when tightening the rear shackle pin assembly and nut. First, the shackle and pin assembly through bolts must be torqued to the specification listed below. Second, torque the shackle and pin assembly retaining bolts to torque listed below. This sequence must be followed to properly seat the bushings into the springs and avoid bending the shackle assembly.

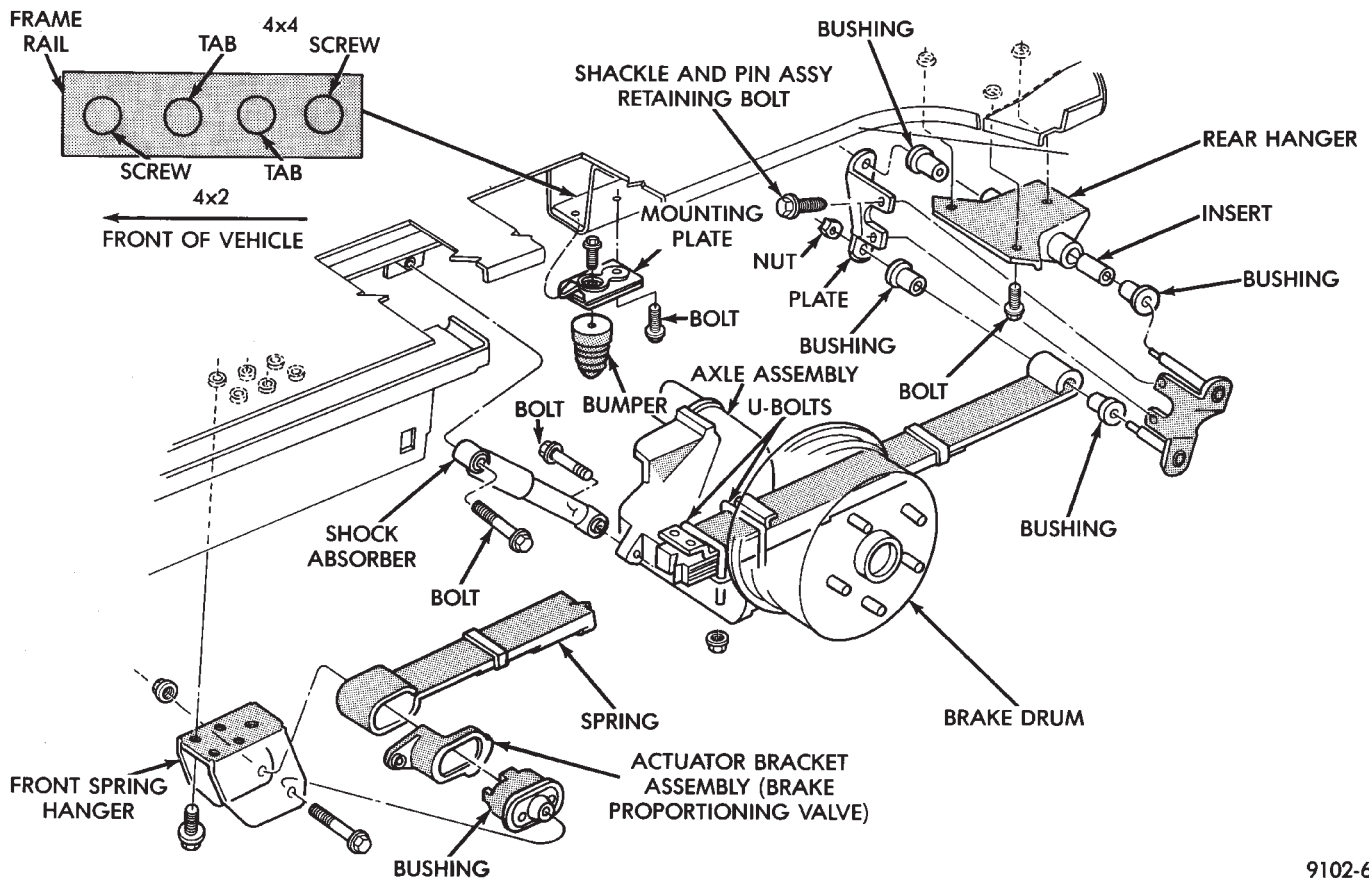

9102-64

Fig. 7 Rear Suspension All Wheel Drive

- Front pivot bolt — 142 N•m (105 ft. lbs.)
- Shackle and pin assembly through bolt nuts— 61 N•m (45 ft. lbs.)
- Shock absorber bolts:
 - Upper — 115 N•m (85 ft. lbs.)
 - Lower — 108 N•m (80 ft. lbs.)

(8) Raise vehicle and connect rear brake proportioning valve spring and adjust (see Adjusting Procedure in Brake Section of this manual).

JOUNCE BUMPER

If the jounce bumper is removed from the vehicle, it must be replaced in the correct location on the frame rail. This location is important so that the

bumper will contact the axle correctly and not interfere with the rear drive shafts.

The frame rail has 4 holes in the area where the jounce bumper mounts. Two of the holes are threaded and two are not. Refer to figure 7 for the tab and screw location of the jounce bumper to frame rail.

REAR SHOCK ABSORBERS

REMOVAL AND INSTALLATION

- (1) Lift vehicle on a frame contact hoist.
- (2) Support axle with a jack stand.
- (3) Remove lower shock bolt.
- (4) While holding shock, remove upper shock bolt.
- (5) To Install, Reverse Removal Procedure.

REAR DRIVE LINE MODULE ASSEMBLY (ALL WHEEL DRIVE)

INDEX

	page		page
Fluid Leak Diagnosis	10	Rear Drive Line Noise Diagnosis	9
General Information	9		

GENERAL INFORMATION

The All Wheel Drive (AWD) system is available on all Caravan/Voyager models equipped with 3.3 Liter V-6 engine and Ultradrive transaxle.

The primary benefit of All Wheel Drive is:

- Superior straight line acceleration, and cornering on all surfaces
- Better traction and handling under adverse conditions, resulting in improved hill climbing ability and safer driving.

The heart of the system is an inter-axle viscous coupling. The vehicle retains predominantly front-wheel drive characteristics, but the All Wheel Drive capability takes effect when the front wheels start to slip. Under normal level road, straight line driving, 90% of the torque is allocated to the front wheels. The viscous coupling allows more torque to the rear wheels in accordance with the amount of the slippage at the front wheels. The variable torque distribution is automatic with no driver inputs required.

The rear drive line module assembly consists of five main parts: the rear carrier, torque tube, overrunning clutch assembly, a vacuum operated dog clutch, and a viscous coupling.

The rear carrier contains a conventional open differential with hypoid ring gear and pinion gear set. The hypoid gears are lubricated by SAE 80W-90 gear lubricant.

The torque tube assembly attaches to the overrunning clutch case. The front torque shaft bearing is located in the torque tube. The front torque shaft bearing is permanently sealed and does not require maintenance. The torque shaft is located within the torque tube assembly. The vacuum reservoir and solenoid assembly are attached to the top of the torque tube.

The overrunning clutch allows the rear wheels to overrun the front wheels during a rapid front wheel lock braking maneuver. The overrunning action prevents any feed-back of front wheel braking torque to the rear wheels. It also allows the braking system to control the braking behavior as a two wheel drive (2WD) vehicle.

The overrunning clutch has a separate oil sump and is filled independently from the differential. The fill plug is located on the side of the overrunning clutch case. When filling the overrunning clutch with

lubricant use Mopar® Type 7176 Automatic Transmission fluid or equivalent.

The dog-clutch provides All Wheel Drive in reverse by bridging and locking out the overrunning clutch. The dog-clutch is operated by a double-acting servo using intake manifold vacuum as its power source. Two vacuum solenoids, controlled by the back up light switch, engage and disengage the dog-clutch. A spring in the vacuum servo disengages the dog clutch if vacuum is lost.

Located in front of the torque tube is the viscous coupling. The viscous coupling controls and distributes torque/power to the rear wheels. The coupling is similar to a multi-plate clutch. It consists of a series of closely spaced discs, alternately connected to the front and rear drive units, which operate in silicone fluid. The unit is totally sealed and partially filled with silicone fluid. There is no adjustment, maintenance or fluid checks required during the life of the unit.

REAR DRIVE LINE NOISE DIAGNOSIS

Different sources can be the cause of noise that the rear drive line module assembly is suspected of making. Refer to the following causes for noise diagnosis.

REAR CARRIER ASSEMBLY NOISE

The most important part of rear carrier service is correctly identifying the cause of failures and noise complaints. The cause of most rear carrier failures is relatively easy to identify. The cause of rear carrier noise is more difficult to identify.

If vehicle noise becomes objectionable, an effort should be made to isolate the noise to one particular area of the vehicle. Many noises that are reported as coming from the rear carrier may actually originate at other sources. For example tires, road surfaces, wheel bearings, engine, transmission, exhaust, propeller shaft (vibration), or vehicle body (drumming). Rear carrier noises are normally divided into two categories: gear noise or bearing noise. A thorough and careful inspection should be completed to determine the actual source of the noise before replacing the rear carrier.

The rear carrier assembly rubber mounting bushings help to dampen-out rear carrier noise when correctly installed. Inspect to confirm that no metal contact exists between the rear carrier case and the

body. Metal-to-metal contact can result in a noise that would not normally be objectionable if the components were correctly installed and tightened. The complete isolation of noise to any one area requires considerable expertise and experience. Identifying certain types of vehicle noise baffles even the most experienced technicians. Often such practices as:

- increase tire inflation pressure to eliminate tire noise.
- listen for noise at varying speeds with different driveline load conditions (e.g., drive, float and coast)
- swerving the vehicle from left to right to detect wheel bearing noise.

All rear carrier assemblies produce noise to a certain extent. Slight carrier noise that is noticeable only at certain speeds or isolated situations should be considered normal. Carrier noise tends to peak at a variety of vehicle speeds and noise is **NOT ALWAYS** an indication of a problem within the carrier.

TIRE NOISE

Tire noise is often mistaken for rear carrier noise. Tires that are unbalanced, worn unevenly or are worn in a saw-tooth manner are usually noisy. They often produce a noise that appears to originate in the rear carrier.

Tire noise changes with different road surfaces, but rear carrier noise does not. Inflate all four tires with approximately 20 psi (138 kPa) more than the recommended inflation pressure (for test purposes only). This will alter noise caused by tires, but will not affect noise caused by the differential. Rear axle noise usually ceases when coasting at speeds less than 30 mph (48 km/h); however, tire noise continues, but at a lower frequency, as the speed is reduced.

After test has been completed lower tire pressure back to recommended pressure.

GEAR NOISE (DRIVE PINION AND RING GEAR)

Abnormal gear noise is rare and is usually caused by scoring on the ring gear and drive pinion. Scoring is the result of insufficient or incorrect lubricant in the carrier housing.

Abnormal gear noise can be easily recognized. It produces a cycling tone that will be very pronounced within a given speed range. The noise can occur during one or more of the following drive conditions:

- Drive
- Road load
- Float
- Coast

Abnormal gear noise usually tends to peak within a narrow vehicle speed range or ranges. It is usually more pronounced between 30 to 40 mph (48 to 64 km/h) and 50 to 60 mph (80 to 96 km/h). When objectionable gear noise occurs, note the driving conditions and the speed range.

BEARING NOISE (DRIVE PINION AND DIFFERENTIAL)

Defective or damaged bearings will normally produce a rough growl that is constant in pitch and varies with the speed of the vehicle. Being aware of this will enable a technician to separate bearing noise from gear noise.

Drive pinion bearing noise that results from defective or damaged bearings can usually be identified by its constant, rough sound. Drive pinion front bearing is usually more pronounced during a coast condition. Drive pinion rear bearing noise is more pronounced during a drive condition. The drive pinion bearings are rotating at a higher rate of speed than either the differential side bearings or the axle shaft bearing.

Differential side bearing noise will usually produce a constant, rough sound that is much lower in frequency than the noise caused by drive pinion bearings.

Bearing noise can best be detected by road testing the vehicle on a smooth road (black top). However, it is easy to mistake tire noise for bearing noise. If a doubt exists, the tire treads should be examined for irregularities that often causes a noise that resembles bearing noise.

ENGINE AND TRANSMISSION NOISE

Occasionally noise that appears to originate in the rear carrier assembly is actually caused by the engine or the transmission. To identify the true source of the noise, note the approximate vehicle speed and/or RPM when the noise is most noticeable. Stop the vehicle next to a flat brick or cement wall (this will help reflect the sound). Place the transaxle in **NEUTRAL**. Accelerate the engine slowly up through the engine speed that approximately corresponds to the vehicle speed or RPM noted when the noise occurred. If a similar noise is produced by this method, it usually indicates that the noise is being caused by the engine or the transaxle.

FLUID LEAK DIAGNOSIS

When diagnosing fluid leaks on the rear drive line module assembly two weep holes are provided to diagnose certain seal leaks. These holes are located on the bottom side of the assembly (Fig. 1).

If fluid leak is detected from either weep hole, seal replacement is necessary. **Do not attempt to repair the leak by sealing weep holes**, they must be kept clear of sealants for proper seal operation.

If fluid is leaking from weep hole "A" (Fig. 1) and it is automatic transmission fluid, the front overrunning clutch seal is leaking. For replacement of this seal, refer to Rear Drive Line Assembly Service Procedures.

If fluid is leaking from weep hole "B" (Fig. 1) the type of fluid leaking will determine which seal is

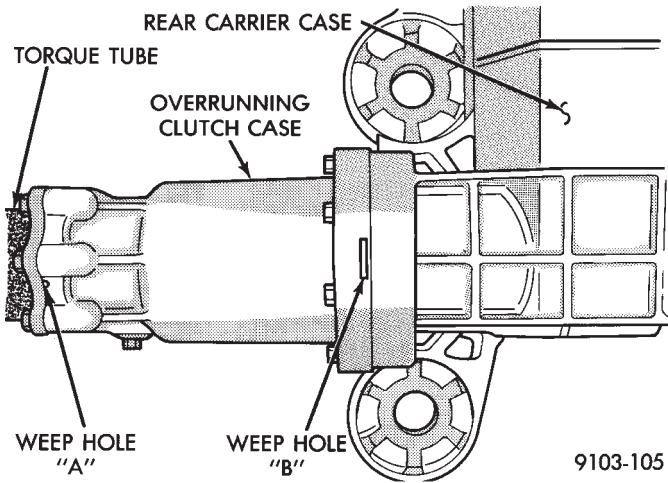

Fig. 1 Weep Hole Locations

leaking. If the fluid leaking is red in color (transmission fluid) this indicates that the rear overrunning clutch seal should be replaced. If the fluid leaking is light brown (hypoid gear lube) this indicates that the drive pinion seal should be replaced. For replacement of these seals refer to Rear Drive Line Assembly Service Procedures.

REAR DRIVE LINE MODULE ASSEMBLY SERVICE PROCEDURES

INDEX

	page		page
Case Cover Service	23	Overrunning Clutch Vacuum Motor	28
Drive Pinion Bearing Shim Selection	21	Propeller Shaft Service	34
Drive Pinion Seal And/Or Rear Overrunning Clutch Seal	19	Rear Carrier Output Shaft Seals	13
Front Overrunning Clutch Seal	15	Rear Carrier Unit	12
Half Shaft Service	34	Rear Drive Line Module Assembly	11
Overrunning Clutch	29	Rear Driveline Module Differential Side Gears	22
		Torque Tube	26

REAR DRIVE LINE MODULE ASSEMBLY

REMOVAL AND INSTALLATION

- (1) Raise vehicle on hoist.
- (2) Remove right and left inner half shaft joint mounting bolts (Fig. 1).

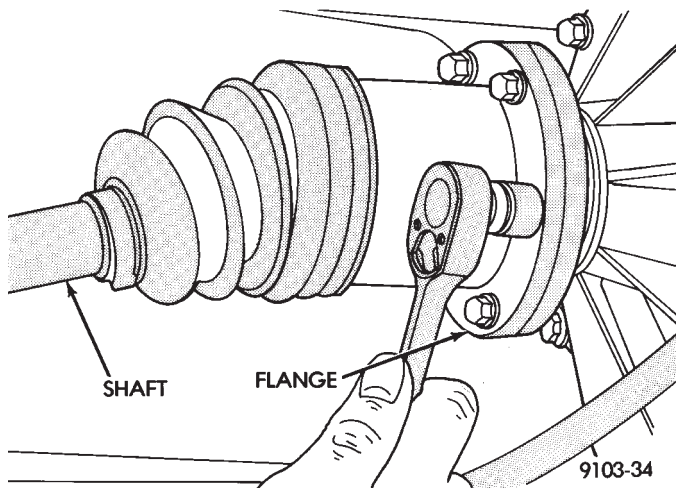

Fig. 1 Remove Mounting Bolts

- (3) Support inner side of half shaft with mechanics wire or equivalent (Fig. 2). Do not allow half shafts to hang freely.

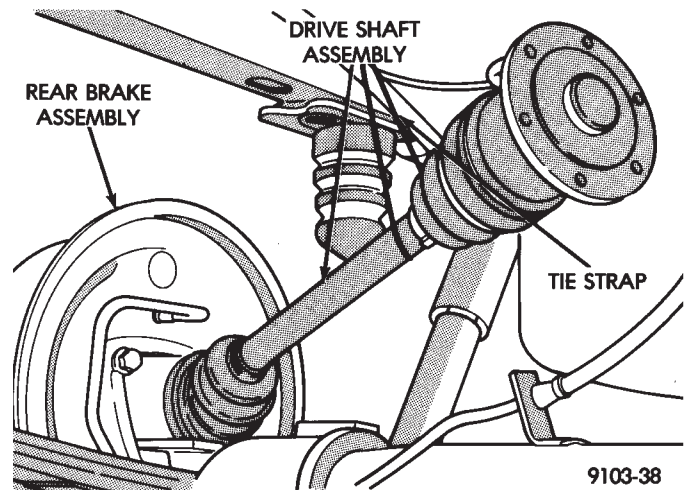

Fig. 2 Support Half Shafts

- (4) Remove mounting bolts from the rear side of propeller shaft (Fig. 3).

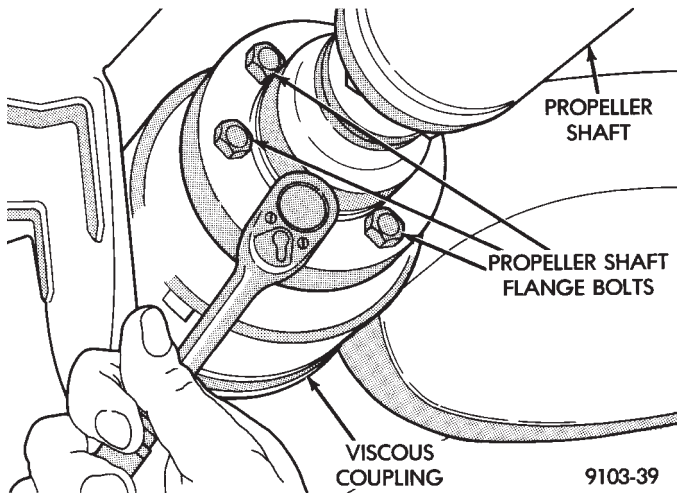

Fig. 3 Remove Mounting Bolts

CAUTION: Do not allow propeller shaft to hang freely

- (5) Support propeller shaft with mechanics wire and/or jack stand
- (6) Disconnect main vacuum line for rear drive line module assembly. Also disconnect electrical connections at the front of the module.
- (7) Support rear drive line module assembly with transmission jack or equivalent.

WARNING: BE SURE TO CHAIN REAR DRIVE LINE MODULE ASSEMBLY SECURELY TO THE JACK TO PREVENT IT FROM FALLING.

- (8) Remove rear drive line module assembly rear mounting bolts (Fig. 4).

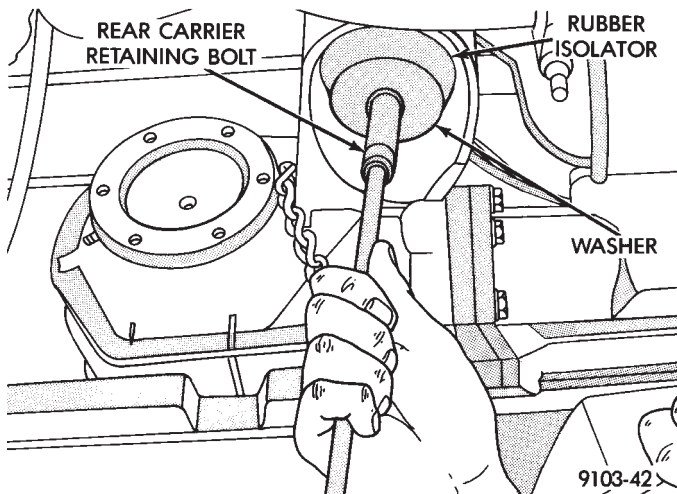

Fig. 4 Rear Drive Line Module Assembly Rear Mounting Bolts

- (9) Remove rear drive line module assembly front mounting bolts (Fig. 5).
- (10) Partially lower rear drive line module assembly and disconnect remote solenoid vent and remote carrier vent.
- (11) Remove rear drive line module assembly.
- (12) To Install, Reverse Removal Procedure. Refer

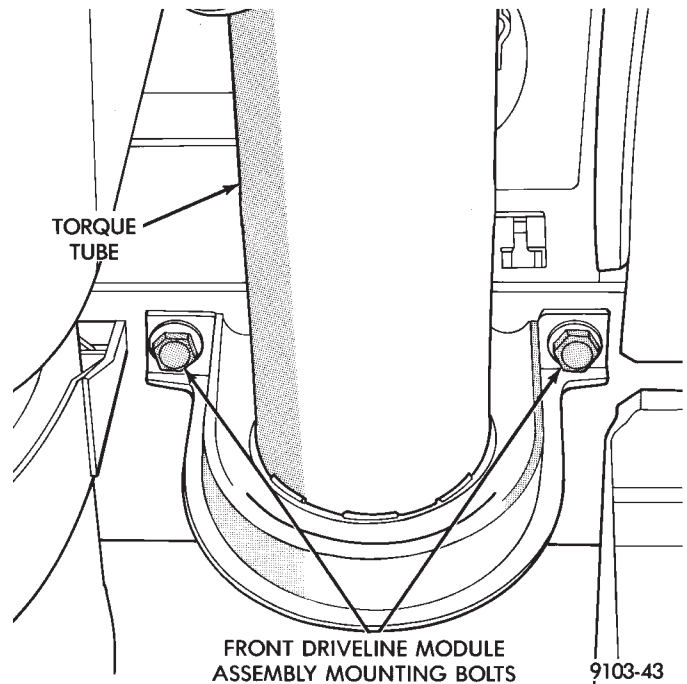

Fig. 5 Rear Drive Line Module Front Mounting Bolts to TORQUE SPECIFICATION in the rear of this section for tightening specifications.

REAR CARRIER UNIT

REMOVAL AND INSTALLATION

- (1) Remove rear drive line module assembly from vehicle.

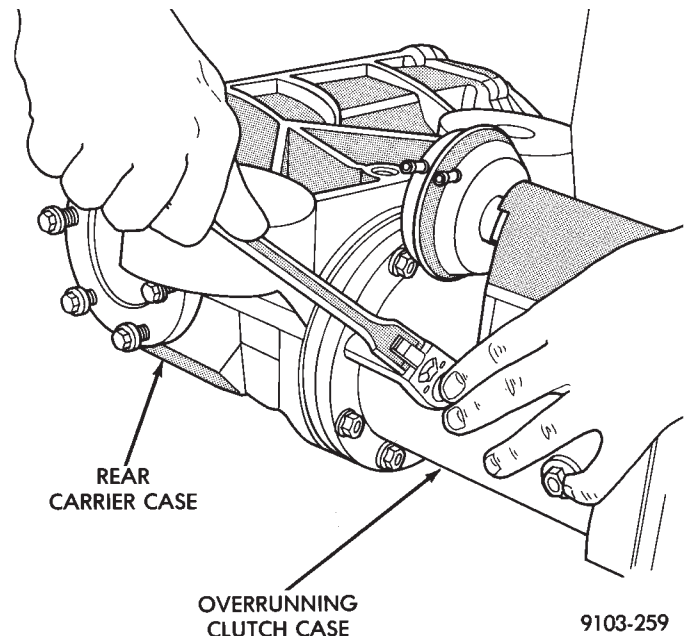

Fig. 6 OVERRUNNING CLUTCH CASE to Rear Carrier Case Bolts

- (2) Drain oil from overrunning clutch case.
- (3) Remove overrunning clutch case to rear carrier case bolts (Fig. 6).
- (4) Separate rear carrier case from overrunning clutch case (Fig. 7).

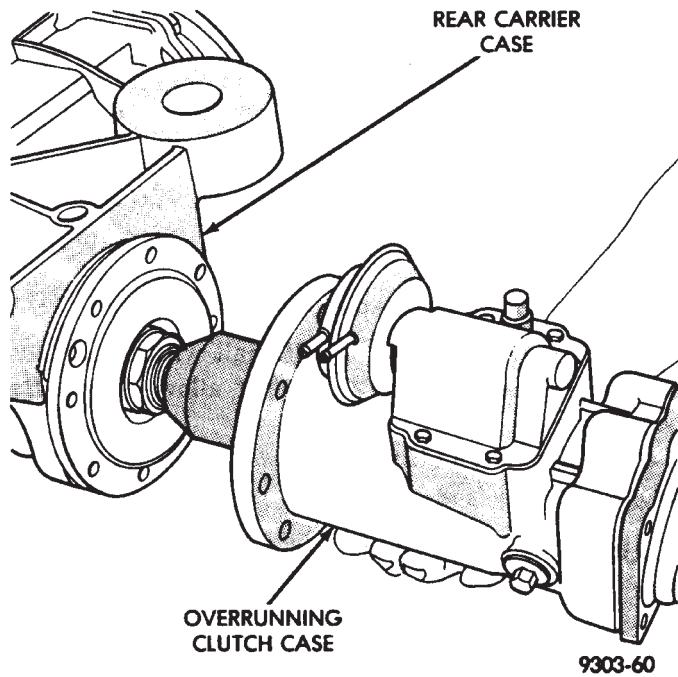

Fig. 7 Separate Rear Carrier Case from Overrunning Clutch Case

- (5) For Installation, Reverse Removal Procedure.

REAR CARRIER OUTPUT SHAFT SEALS

The rear drive line module assembly does not have to be removed from vehicle to service the carrier output shaft seals.

The output flange seals are located on the rear carrier unit (Fig. 1).

REMOVAL

- (1) Remove inner half shaft retaining bolts (Fig. 2).

CAUTION: Do not allow half shafts to hang freely

- (2) Support inner side of half shaft with mechanics wire or equivalent (Fig. 3).
- (3) Using two pry bars and wooden support blocks, pop out output shaft (Fig. 4).

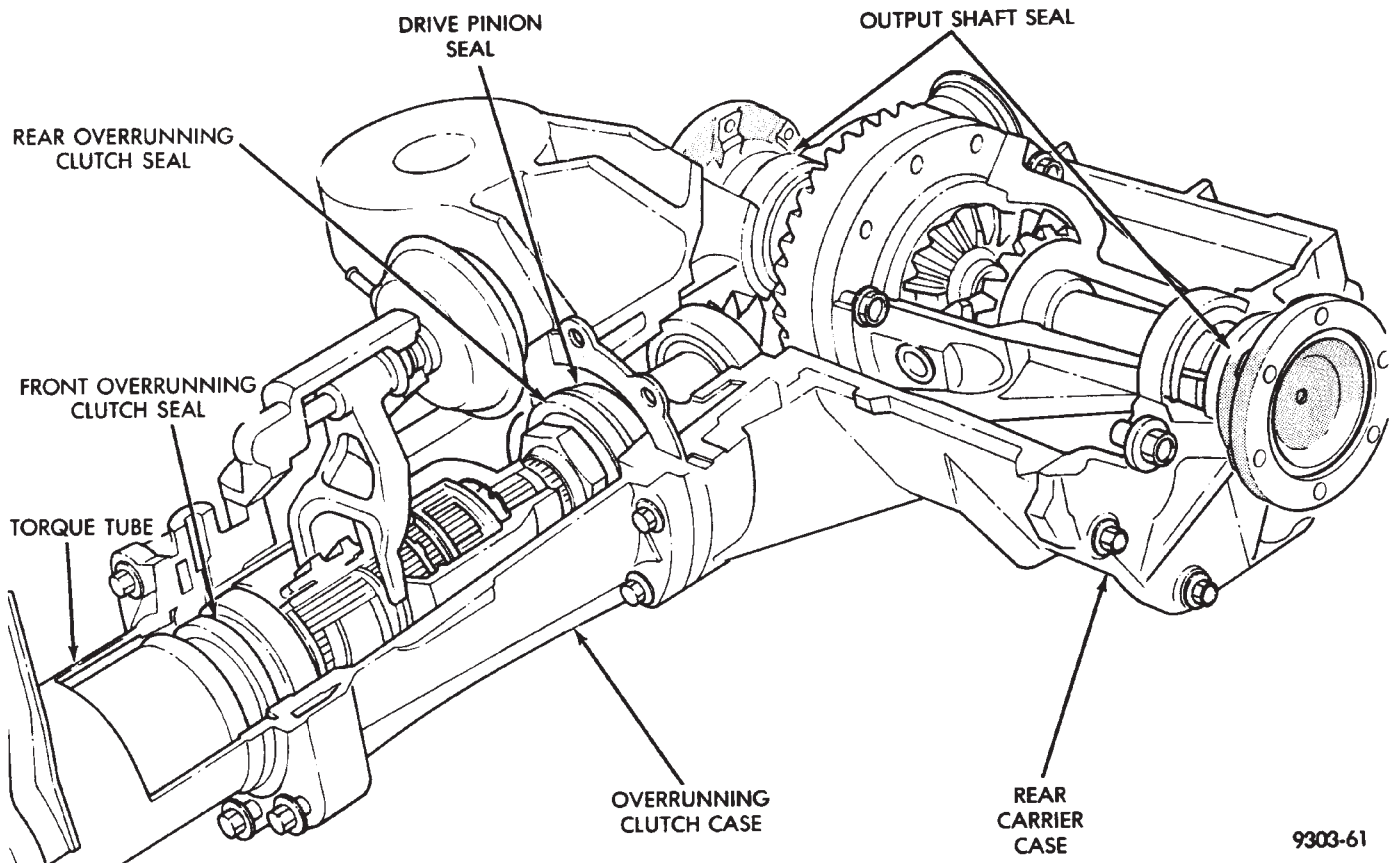

Fig. 1 Rear Drive Line Module Oil Seal Location

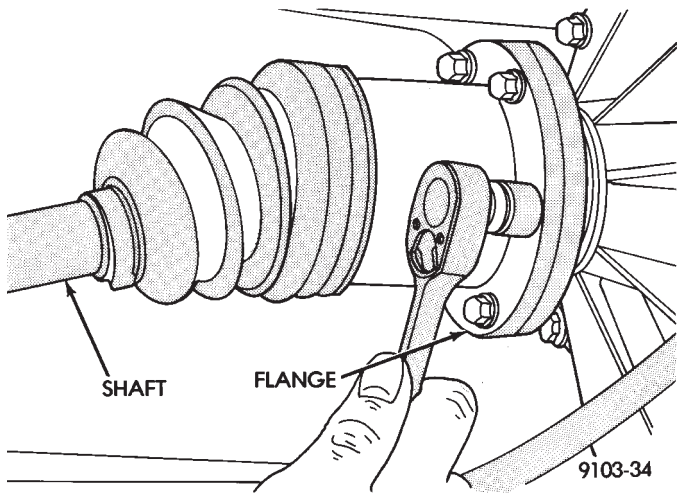

Fig. 2 Inner Half Shaft Bolts

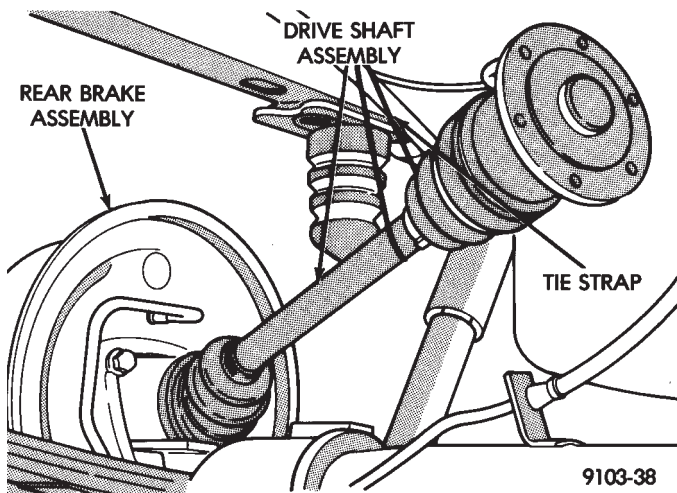

Fig. 3 Support Half Shafts

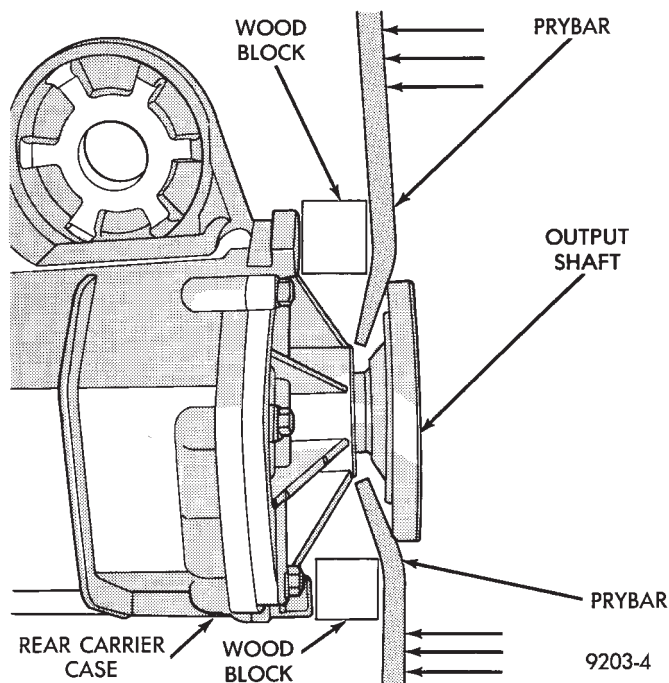

Fig. 4 Output Flange Removal

(4) Using a pry bar, pry out oil seal (Fig. 5), being careful not to damage race.

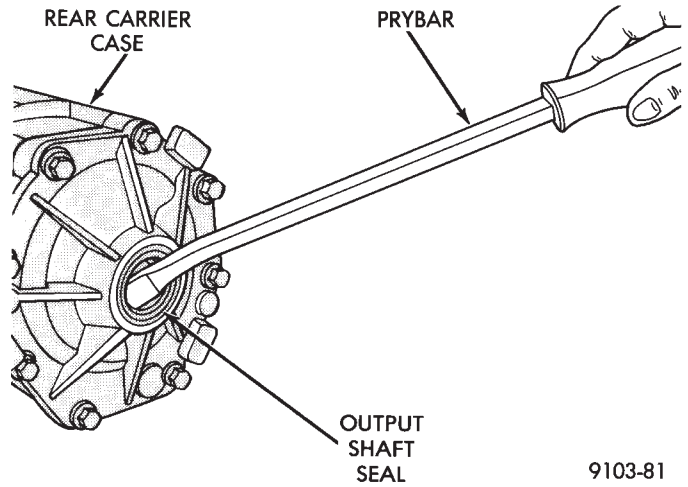

Fig. 5 Seal Removal

INSTALLATION

- (1) Clean and inspect shaft and seal area.
- (2) Install oil seal with special tool MD998334 (Fig. 6).

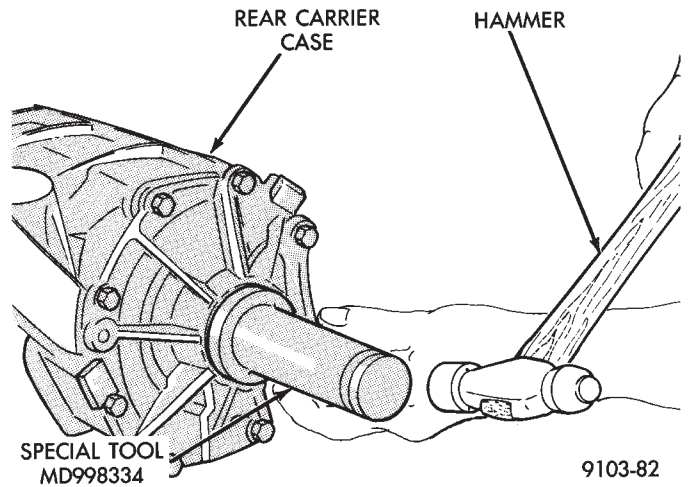

Fig. 6 Installing Oil Seal

(3) Install output shaft (Fig. 7). Lightly tap shaft to seat retainer ring into differential side gear.

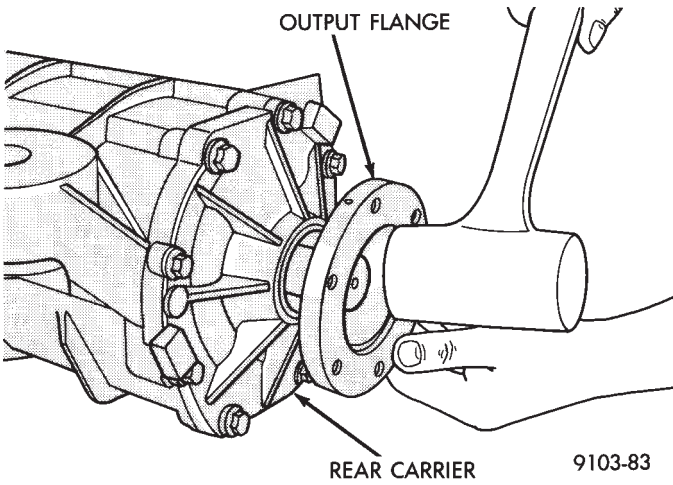

Fig. 7 Installing Output Shaft

(4) Check differential fluid level, fill as required.

FRONT OVERRUNNING CLUTCH SEAL

The rear drive line module must be removed to service this seal.

The front overrunning clutch seal is located in the overrunning clutch case (Fig. 1).

REMOVAL

- (1) Remove rear drive line module assembly from vehicle.
- (2) Remove viscous coupling unit.
- (3) Remove overrunning clutch cover assembly.
- (4) Drain fluid from overrunning clutch case.
- (5) Remove overrunning clutch case to rear carrier bolts (Fig. 8).

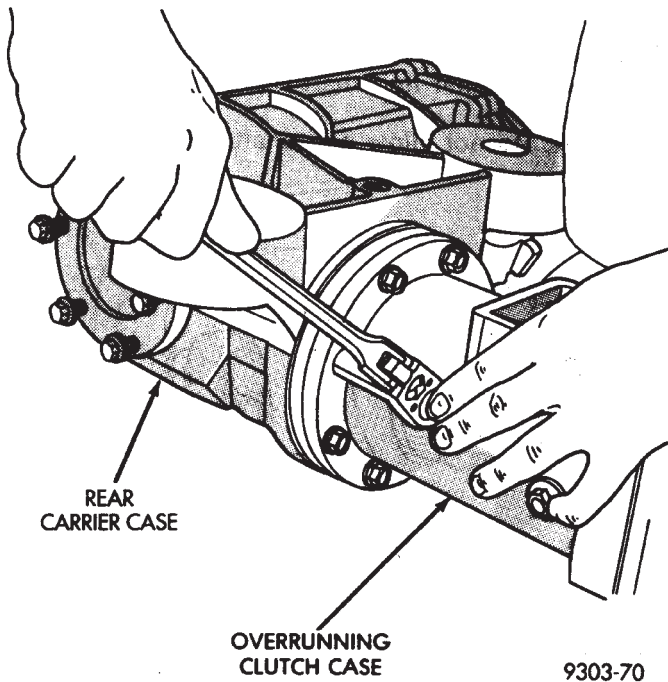

Fig. 8 Overrunning Clutch Case to Rear Carrier Bolts

(6) Separate overrunning clutch case from rear carrier case (Fig. 9).

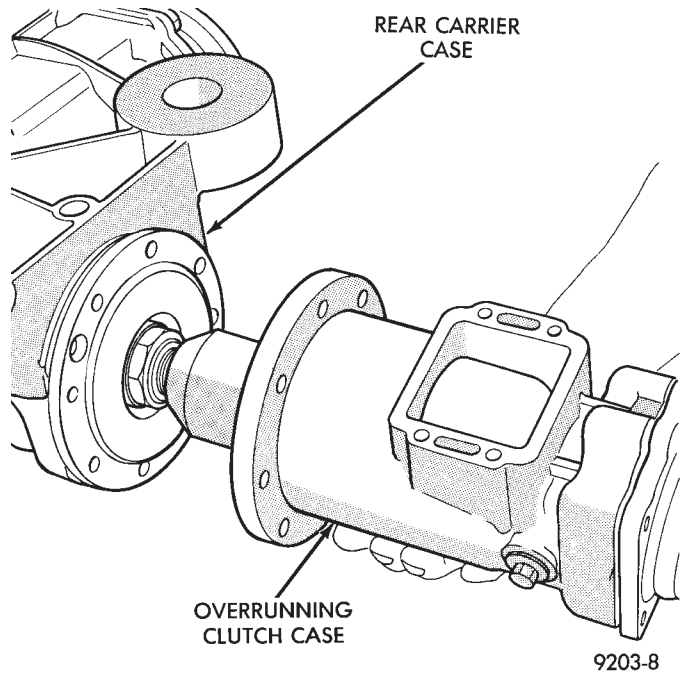

Fig. 9 Separate Housings

(7) Remove overrunning clutch inner race snap ring (Fig. 10).

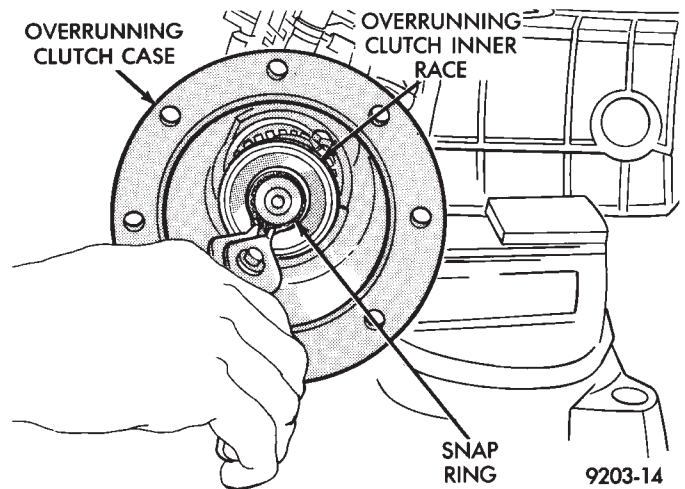

Fig. 10 Inner Race Snap Ring Removal

(8) Slide overrunning clutch inner race off of shaft (Fig. 11).

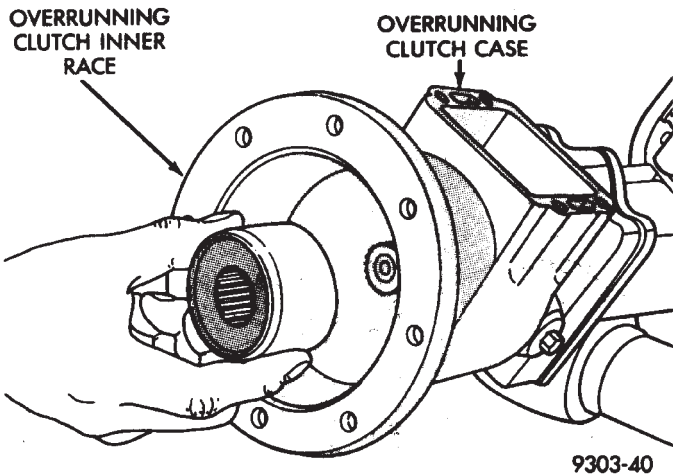

Fig. 11 Remove Overrunning Clutch Inner Race

(9) Remove shaft snap ring and slide dog clutch off of the shaft (Fig. 12).

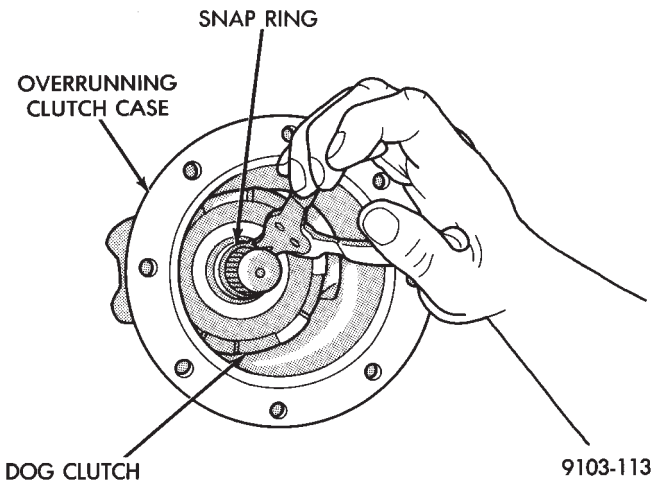

Fig. 12 Remove Snap Ring

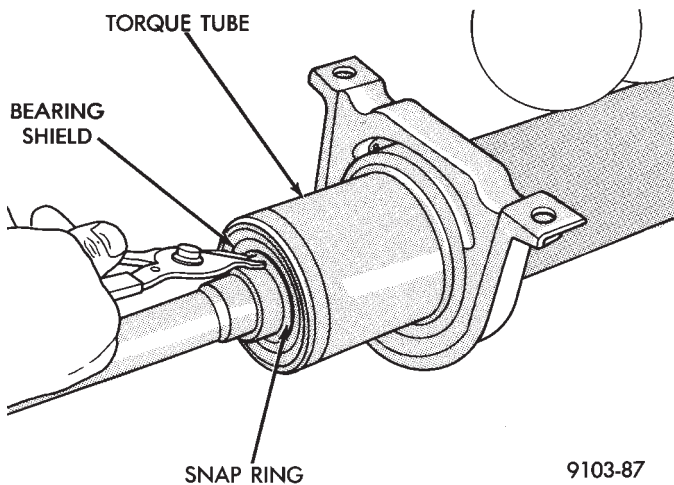

Fig. 13 Remove Torque Shaft Snap Ring and Torque Tube Bearing Shield

CAUTION: Note the position that the snap ring was removed. The snap ring can be accidentally installed backwards. The snap ring is concave and the fingers on the snap ring must angle towards the bearing shield.

- (10) Remove torque shaft snap ring (Fig. 13) and torque tube bearing shield.
- (11) Remove torque tube retaining bolts (Fig. 14).

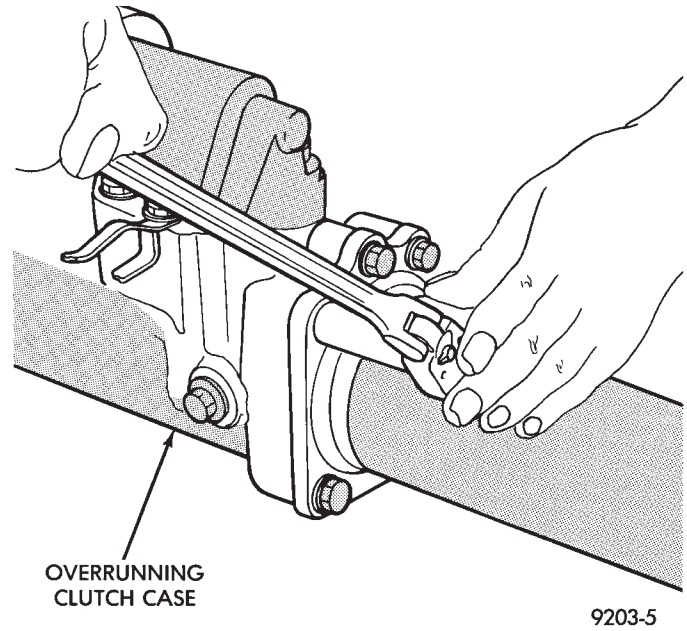

Fig. 14 Torque Tube Bolts

- (12) Remove inner torque shaft bearing snap ring.
- (13) Separate overrunning clutch case from torque tube.

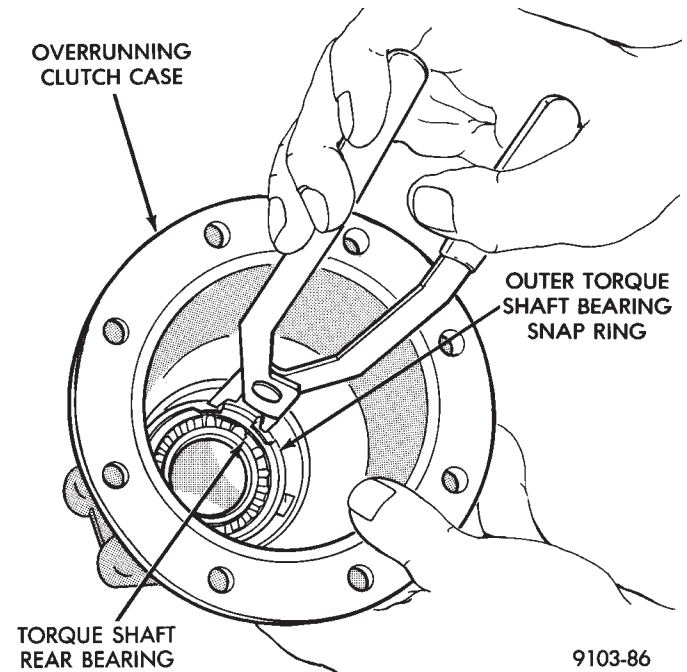

Fig. 15 Torque Shaft Rear Bearing Snap Ring

- (14) Remove rear torque shaft bearing retaining outer snap ring in overrunning clutch case (Fig. 15).
- (15) Remove rear torque shaft bearing.
- (16) Drive out seal with special tool C-4967 (Fig. 16)

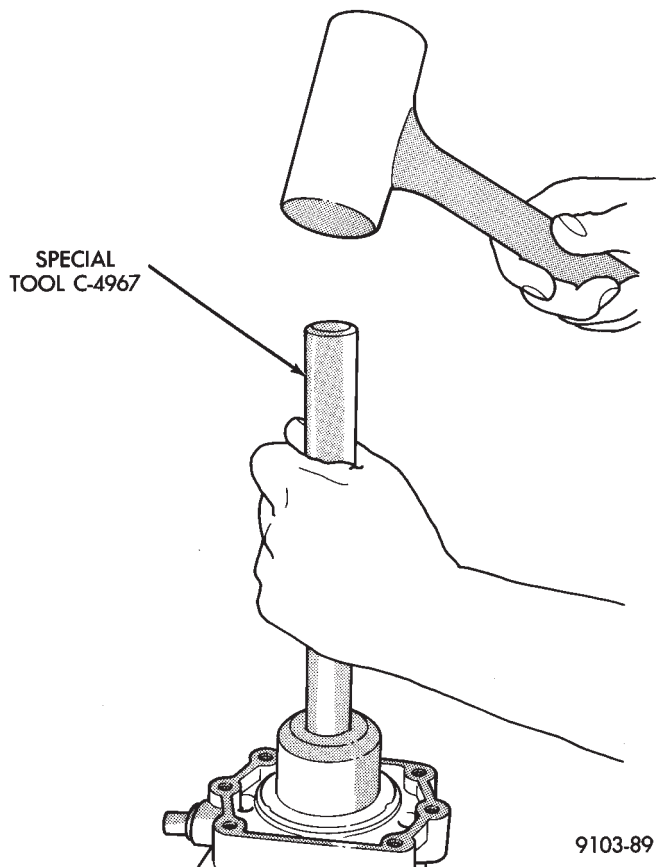

Fig. 16 Seal Removal

INSTALLATION

- (1) Clean and inspect shaft sealing surface and case for nicks or grooves. Replace as required.
- (2) Install new seal with special tool MD998334. Seal should be flush with outside edge of case (Fig. 17).
- (3) Install rear torque shaft bearing and outer snap ring.
- (4) Install overrunning clutch case onto torque tube. Tighten bolts to 28 N•m (250 in. lbs.).
- (5) Install torque shaft inner snap ring.
- (6) Slide dog clutch onto shaft and install snap ring.

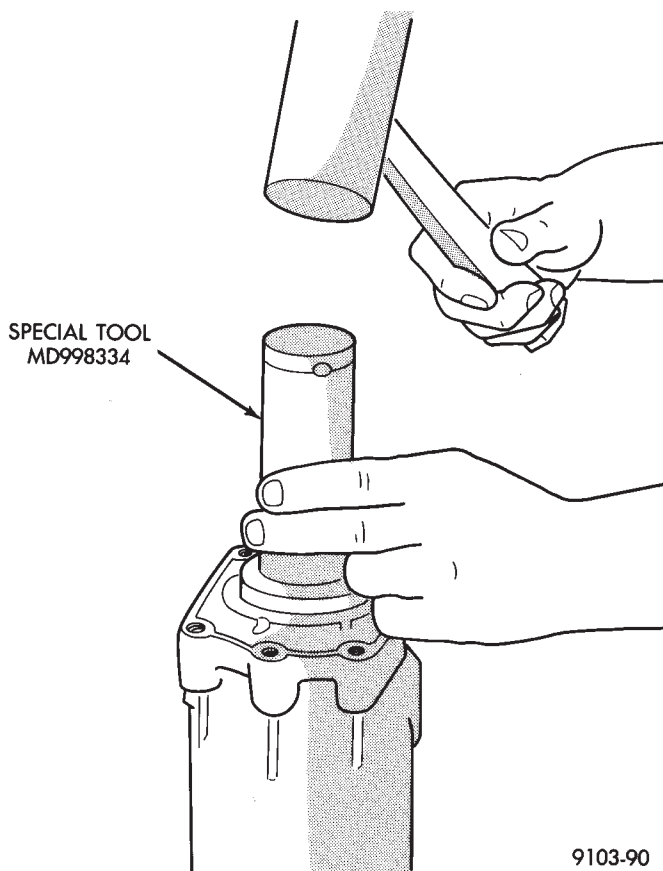

Fig. 17 Installing New Seal

- (7) Slide overrunning clutch inner race onto shaft and install retaining snap ring (tapered end of inner race must face outward).
- (8) Clean all sealing surfaces. Apply a bead of Mopar Gasket Maker or equivalent and reinstall the overrunning clutch housing to the rear carrier case. Install retaining bolts and tighten to 28 N•m (250 in. lbs.).
- (9) Apply Mopar® Gasket Maker, Loctite Gasket Eliminator or equivalent and reinstall overrunning clutch cover. When installing cover be sure that the overrunning clutch fork engages into the overrunning clutch dog.
- (10) Install rear drive line module assembly into vehicle.
- (11) Check and fill fluid levels as required.

DRIVE PINION SEAL AND/OR REAR OVERRUNNING CLUTCH SEAL

The rear drive line module must be removed to service these seals. The drive pinion seal is located in the front carrier cover, behind the overrunning clutch rear seal (Fig. 1). The overrunning clutch seal must be removed to gain access to the drive pinion seal. Do not reuse overrunning clutch seal.

REMOVAL

- (1) Remove rear drive line module from vehicle.
- (2) Remove overrunning clutch case to rear carrier bolts (Fig. 1).

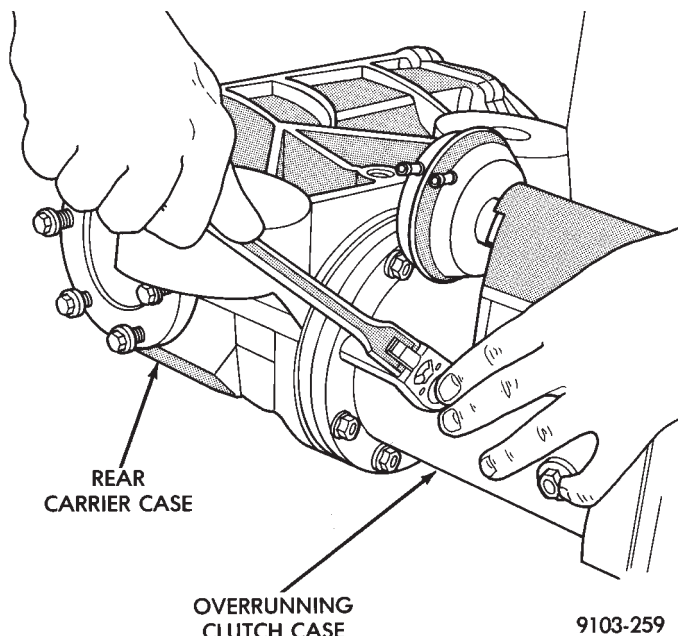

Fig. 1 Overrunning Clutch Case to Rear Carrier Bolts

- (3) Separate overrunning clutch case from differential carrier case (Fig. 2).

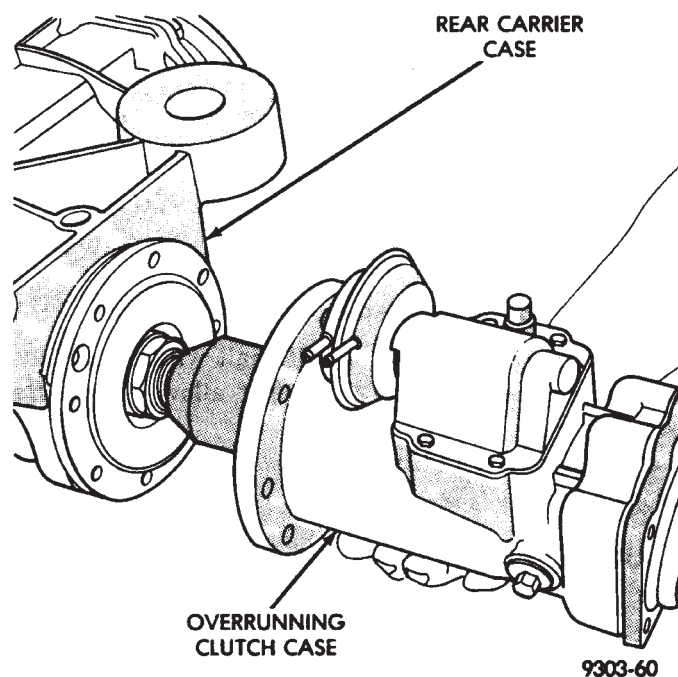

Fig. 2 Separate Cases

- (4) Remove overrunning clutch outer race snap ring (Fig. 3).

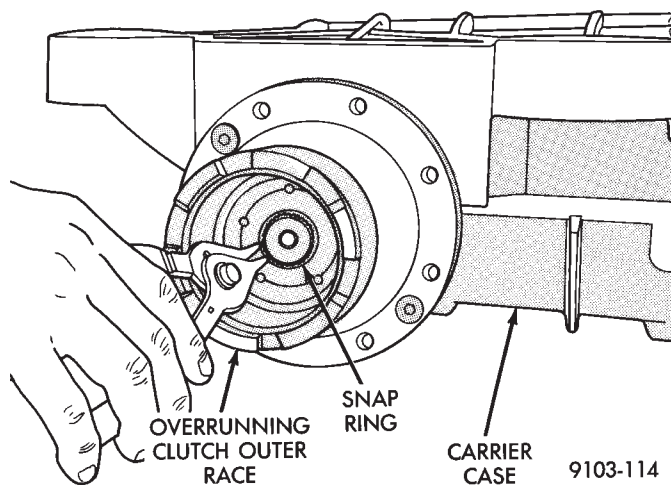

Fig. 3 Overrunning Clutch Snap Ring Removal

- (5) Slide overrunning clutch outer race off of shaft (Fig. 4).

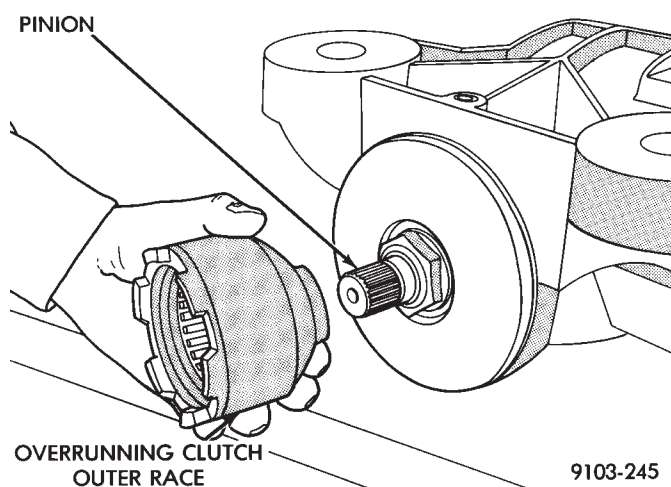
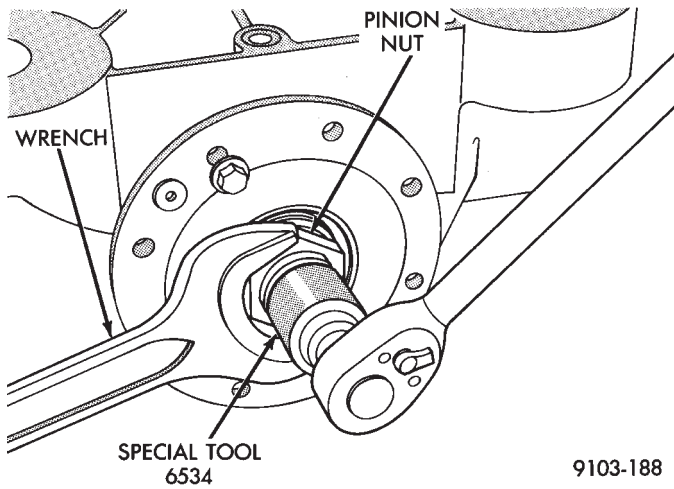

Fig. 4 Overrunning Clutch Outer Race Removal

- (6) Using Spline Socket Tool 6534 and a wrench, remove pinion nut (Fig. 5).
- (7) Remove front carrier cover retaining screws (Fig. 6)
- (8) Remove front carrier cover from carrier case (Fig. 7).
- (9) Place a block of wood under the end of the pinion shaft. Tap end of pinion against the wood to drive the pinion spacer off of the pinion shaft (Fig. 8).

CAUTION: Shim should be installed with front carrier cover. This will eliminate the potential of cutting the O-Ring with the shim.

- (10) Reinstall front carrier cover into carrier case (Fig. 9). Install carrier retaining bolts and tighten to 12 N•m (105 in. lbs.).



9103-188

Fig. 5 Remove Pinion Nut

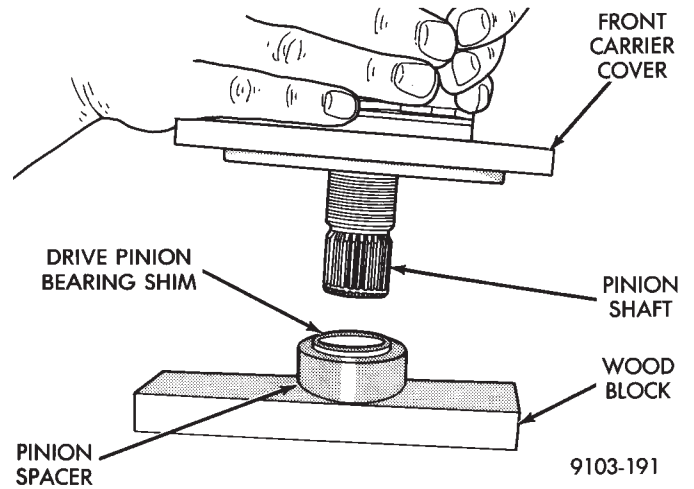

9103-191

Fig. 8 Removing Drive Pinion Spacer

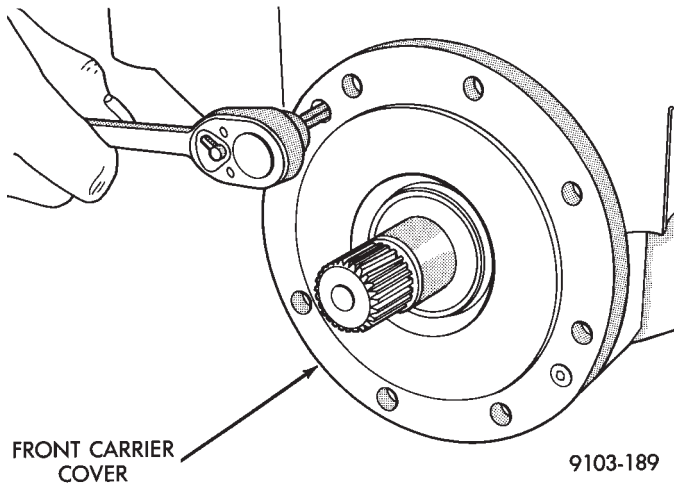

9103-189

Fig. 6 Front Carrier Cover Retaining Screws

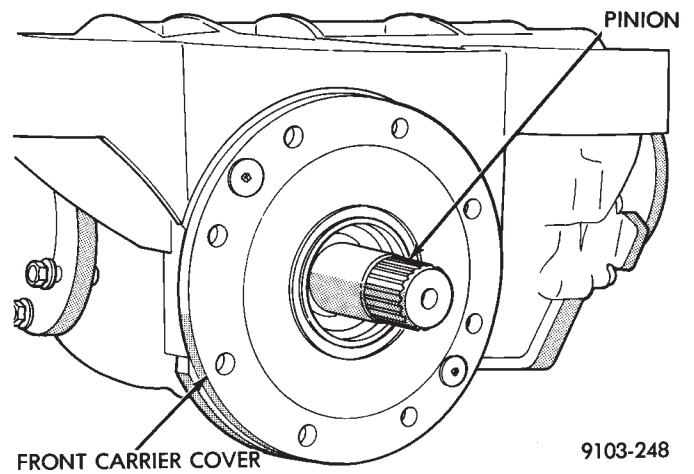

9103-248

Fig. 9 Reinstalling Front Carrier Cover

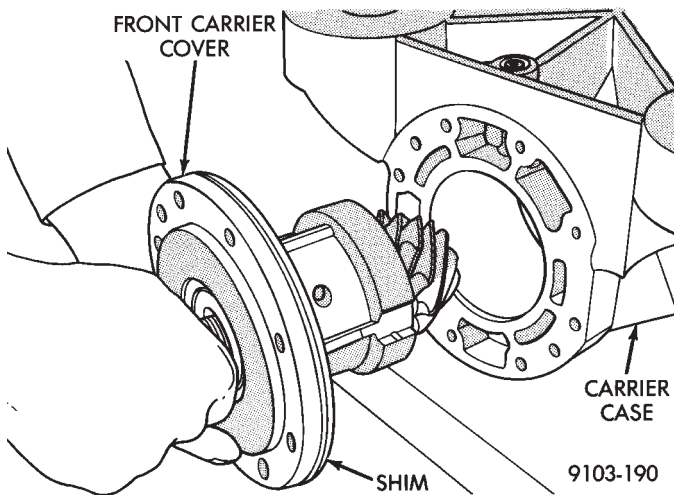

9103-190

Fig. 7 Front Carrier Cover

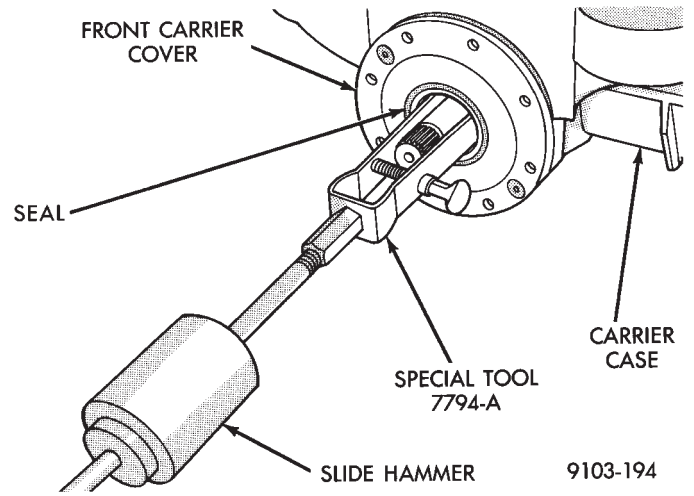

9103-194

Fig. 10 Removing Seals

(11) Use seal puller 7794-A (Fig. 10) to remove the overrunning clutch seal and drive pinion seal. The overrunning clutch seal must be removed first to gain access to the drive pinion seal. The overrunning clutch seal must be replaced after the drive pinion

seal is installed, do not reuse old seal.

INSTALLATION

- (1) Clean and inspect seal area.

(2) Apply a light coat of oil onto the drive pinion seal and install with Seal Installer 6507. Seal must be installed with the spring side in towards the rear carrier case (Fig. 11).

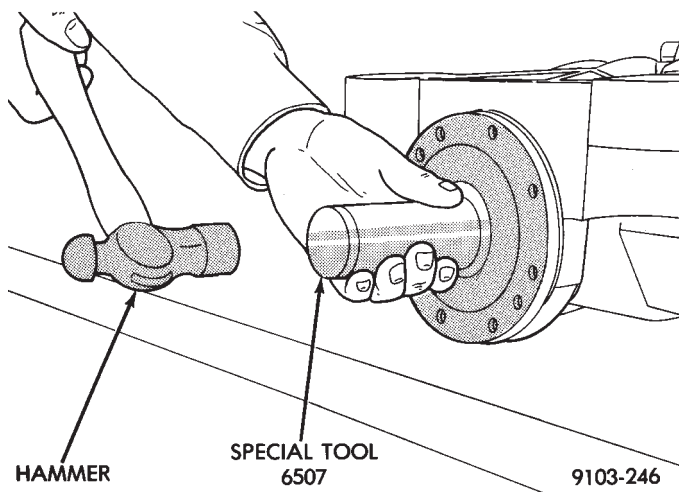

Fig. 11 Input Seal Installation

CAUTION: If the drive pinion spacer is grooved or damaged it must be replaced. A new drive pinion bearing shim may be required. Refer to Drive Pinion Bearing Shim Selection in this section before continuing with this procedure.

(3) Apply a light coat of oil onto the drive pinion spacer. Then slide onto the pinion shaft with the tapered side facing outward (Fig. 12).

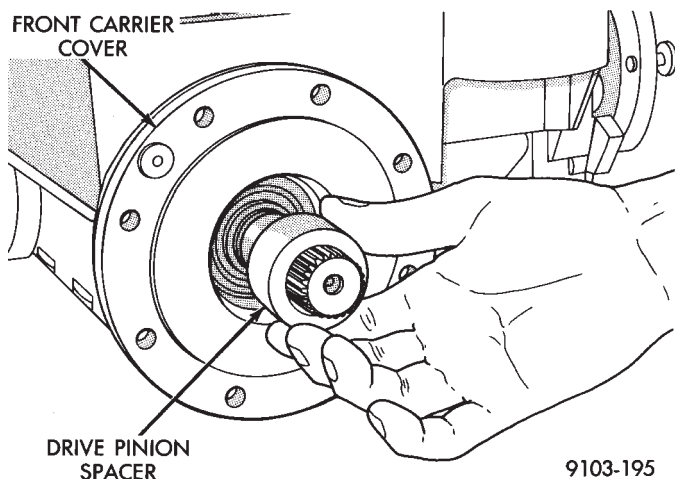

Fig. 12 Installing Drive Pinion Spacer onto Pinion

(4) Apply a light coat of oil onto the overrunning clutch seal and install with Seal Installer 6508. Seal must be installed with the spring side away from the rear carrier case (Fig. 13).

(5) Clean pinion nut and pinion shaft threads with Mopar® Brake and Parts Cleaner, Loctite Cleaning Primer or equivalent.

(6) Apply Mopar® Lock and Seal Adhesive to both the pinion nut and pinion shaft threads.

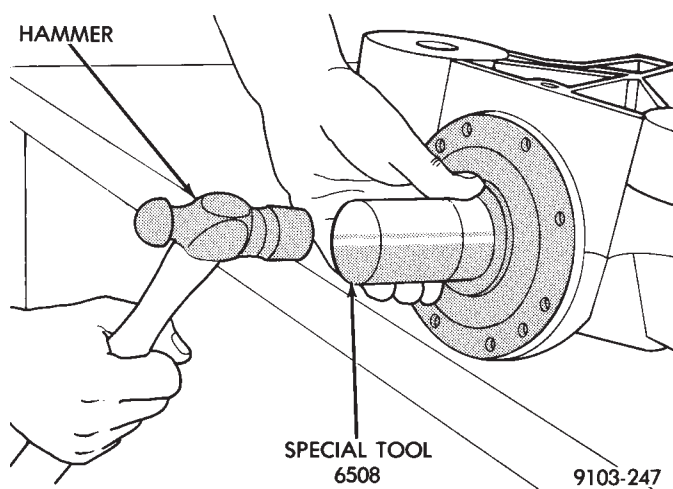

Fig. 13 Overrunning Clutch Seal Installation

(7) Install pinion and tighten nut to 340 N•m (250 ft. lbs.) torque.

(8) Wipe off all excess adhesive.

(9) Install overrunning clutch outer race and snap ring.

(10) Apply Loctite Sealer to overrunning clutch sealing surface and reinstall the overrunning clutch case to rear carrier case.

(11) Reinstall rear drive line module assembly into the vehicle.

(12) Check and fill all fluids as required.

DRIVE PINION BEARING SHIM SELECTION

This procedure must be performed when ever the drive pinion spacer has been replaced.

(1) Using a one inch micrometer, measure the thickness of the **original spacer** (Fig. 14).

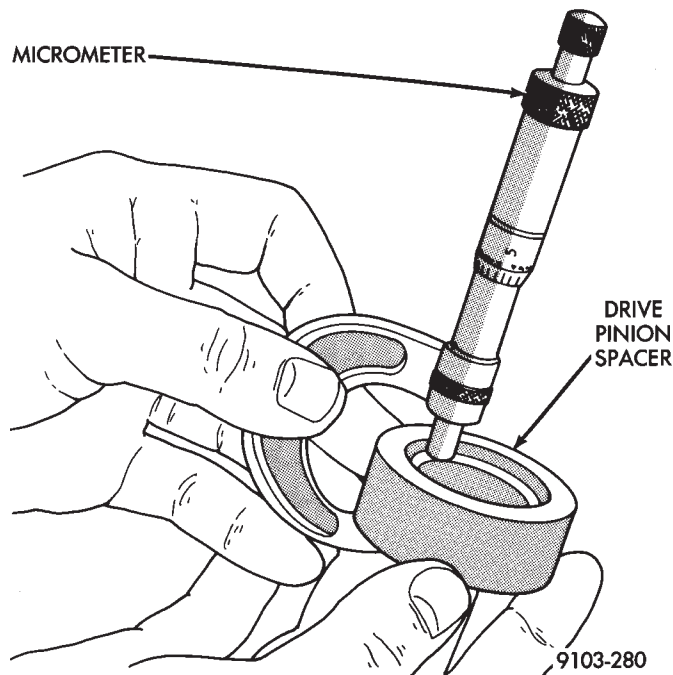

Fig. 14 Measuring Drive Pinion Spacer Thickness

(2) Measure the thickness of the **new spacer** the same way that the original spacer was measured.

The difference in the measurements of the old spacer and the new spacer will determine which shim to use.

If the new drive pinion spacer is the **same thickness** as the original drive pinion spacer use the original shim.

If the new drive pinion spacer is **thinner** than the original drive pinion spacer, a thicker shim will must be used. This will compensate for the difference in size.

(a) Determine the difference in size between the new spacer and the original spacer. Record this dimension.

(b) Measure the thickness of the original shim. Record this dimension.

(c) Add together the two dimensions recorded in steps (a) and (b). Use a new shim that is equal to this size.

For Example: The new spacer is 0.010 thinner than the original spacer. The original shim measures 0.205 . Adding 0.205 and 0.010 equals a new shim thickness of 0.215 .

(3) If the new drive pinion spacer is **thicker** than the original drive pinion spacer, a thinner shim will must be used. This will compensate for the difference in size.

(a) Determine the difference in size between the new spacer and the original spacer. Record this dimension.

(b) Measure the thickness of the original shim. Record this dimension.

(c) Subtract the dimensions recorded in steps (a) from the dimension recorded in step (b). Use a new shim that is equal to this size.

For Example: The new spacer is 0.010 thicker than the original spacer. The original shim measures 0.205 . Subtracting 0.010 from 0.205 equals a new shim thickness of 0.195 .

REAR DRIVELINE MODULE DIFFERENTIAL SIDE GEARS

(1) Disconnect both half shafts from rear driveline module.

(2) Using two pry bars, pop out output shaft.

(3) Remove output shaft.

(4) Remove end cover retaining bolts.

(5) Remove differential end cover.

(6) Remove differential assembly from rear driveline case.

(7) Remove ring gear bolts and separate differential case from differential body.

(8) Using a punch and hammer remove the differential pinion shaft pin.

(9) Slide differential pinion shaft out of differential case.

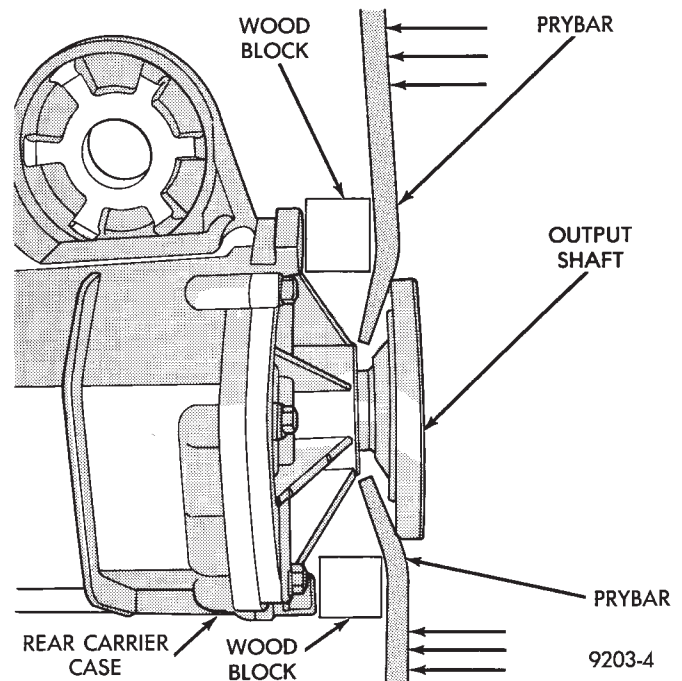

Fig. 1 Output Flange Removal

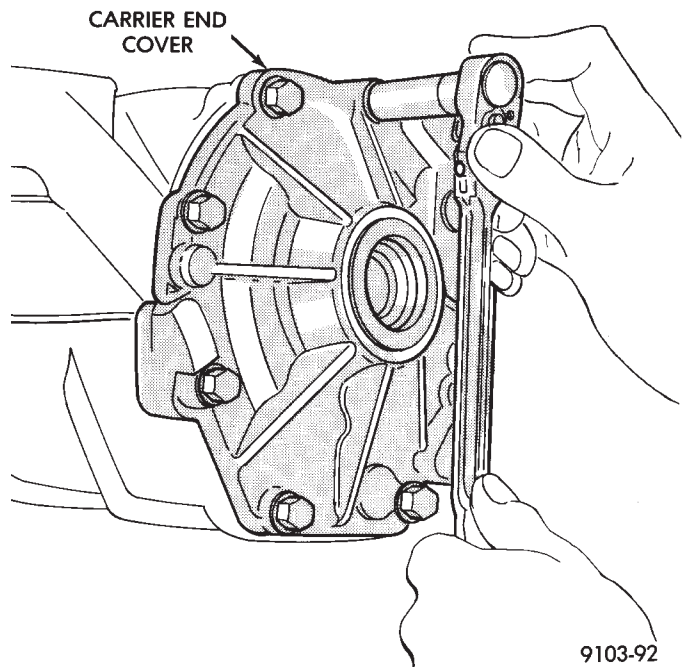

Fig. 2 Remove End Cover Bolts

(10) Inspect and replace pinion gears, pinion shaft or pinion washers as required.

(11) Reverse steps 7 through 10 to assemble differential. Torque the ring gear bolts to 95 N•m (70 ft. lbs.).

(12) Install differential assembly into driveline module case.

(13) Clean and inspect sealer surfaces.

(14) Apply Mopar® Gasket Maker, Loctite Gasket Eliminator or equivalent and install end cover. Tighten to 28 N•m (250 in. lbs.).

(15) Tighten bolts in proper sequence (Fig. 3). Retighten first bolt after all others are tight.

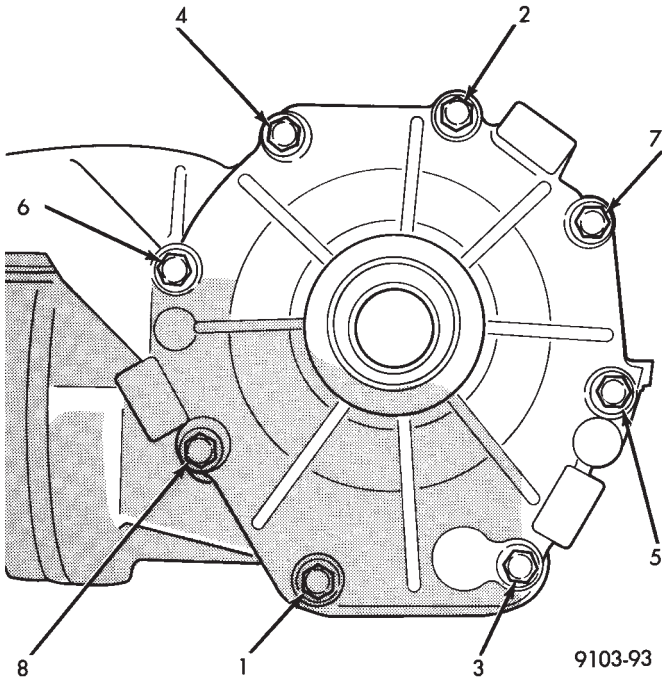

Fig. 3 Bolt Tightening Sequence.

- (16) Install output shafts
- (17) Reconnect both half shafts.
- (18) Fill differential with lubricant.

CASE COVER SERVICE

DIFFERENTIAL CARRIER END COVER (RESEAL)

- (1) Remove left half shaft.
- (2) Using two pry bars, pop out output shaft (Fig. 1).
- (3) Remove output shaft.
- (4) Remove end cover retaining bolts (Fig. 2).
- (5) Remove differential end cover.
- (6) Clean and inspect sealer surfaces.
- (7) Apply Mopar® Gasket Maker, Loctite Gasket Eliminator or equivalent and install end cover. Tighten to 28 N•m (250 in. lbs.).
- (8) Tighten bolts in the sequence shown in Fig. 3. Retighten first bolt after all others are tight.
- (9) Fill differential with lubricant.

OVERRUNNING CLUTCH COVER (RESEAL)

- (1) Remove rear drive line module assembly from vehicle.
- (2) Remove overrunning clutch cover assembly mounting bolts (Fig. 4).
- (3) Lift overrunning clutch cover off of overrunning clutch housing.
- (4) Clean and inspect sealing surfaces.
- (5) Apply Mopar® Gasket Maker, Loctite Gasket Eliminator or equivalent and reinstall cover and vac-

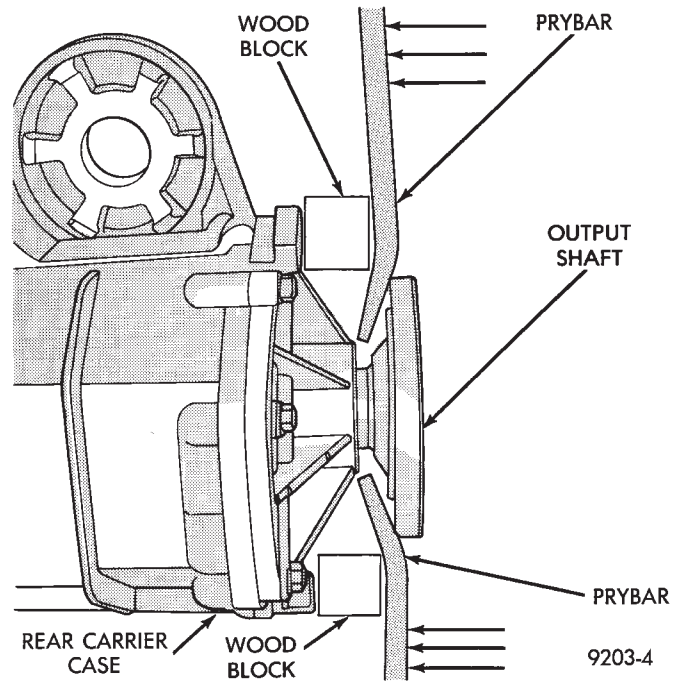

Fig. 1 Output Flange Removal

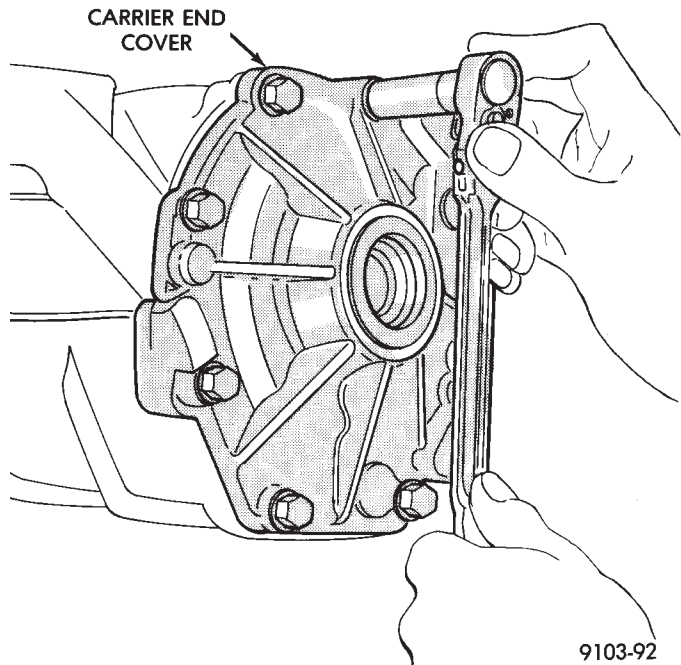

Fig. 2 Remove End Cover Bolts

uum hose clip. When installing cover be sure that the overrunning clutch fork engages into the overrunning clutch dog.

(6) Install overrunning clutch cover mounting bolts and tighten bolts to 28 N•m (250 in. lbs.).

(7) Reinstall rear drive line module assembly into vehicle.

(8) Check and fill fluid levels as required. Use only MOPAR® TYPE 7176 Automatic Transmission Fluid or equivalent in the overrunning clutch case.

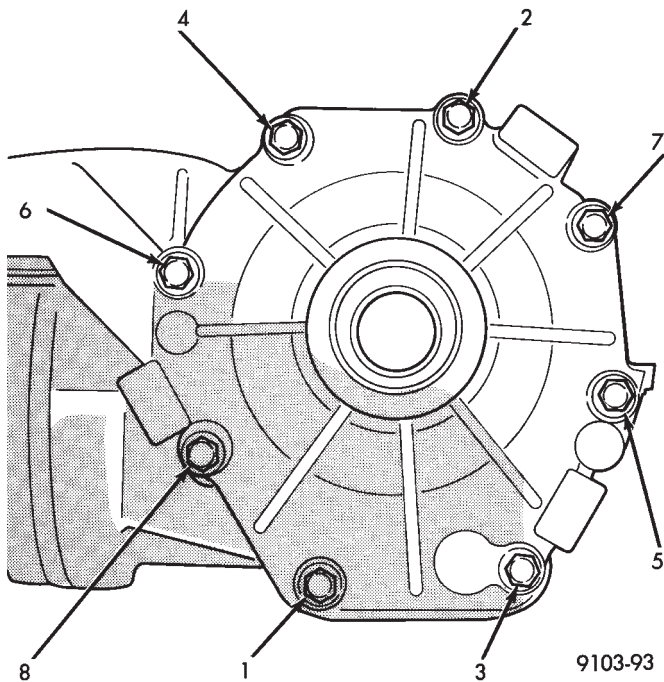

Fig. 3 Bolt Tightening Sequence.

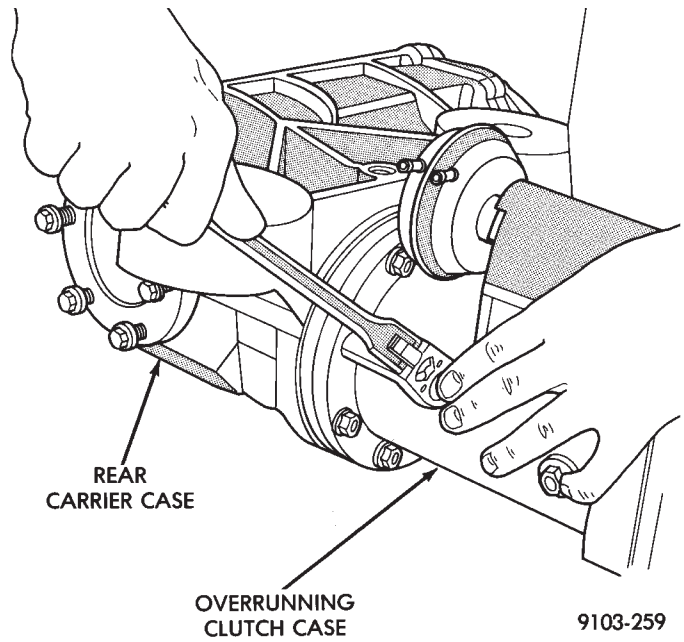

Fig. 5 Overrunning Clutch Case to Rear Carrier Bolts

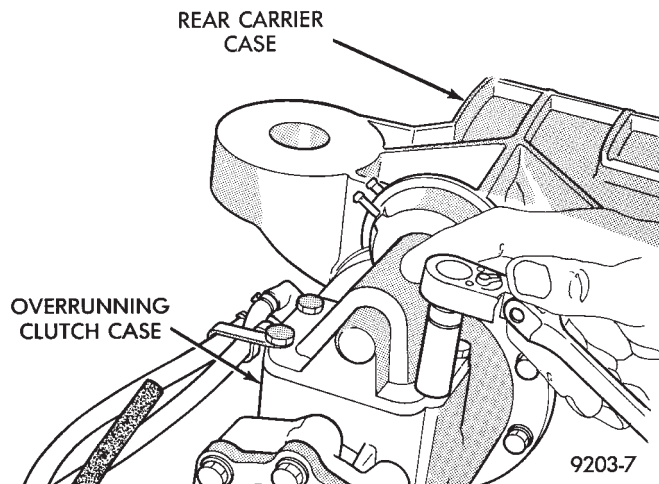

Fig. 4 Mounting Bolts

OVERRUNNING CLUTCH CASE TO REAR CARRIER CASE (RESEAL)

- (1) Remove rear drive line module assembly from vehicle.
- (2) Drain fluid from overrunning clutch case.
- (3) Remove overrunning clutch case to rear carrier bolts (Fig. 5).
- (4) Separate overrunning clutch case from rear carrier unit (Fig. 6).
- (5) Clean and inspect sealing surfaces.
- (6) Apply a bead of Mopar® Gasket Maker, Loctite Gasket Eliminator or equivalent to sealing surfaces and reassemble.

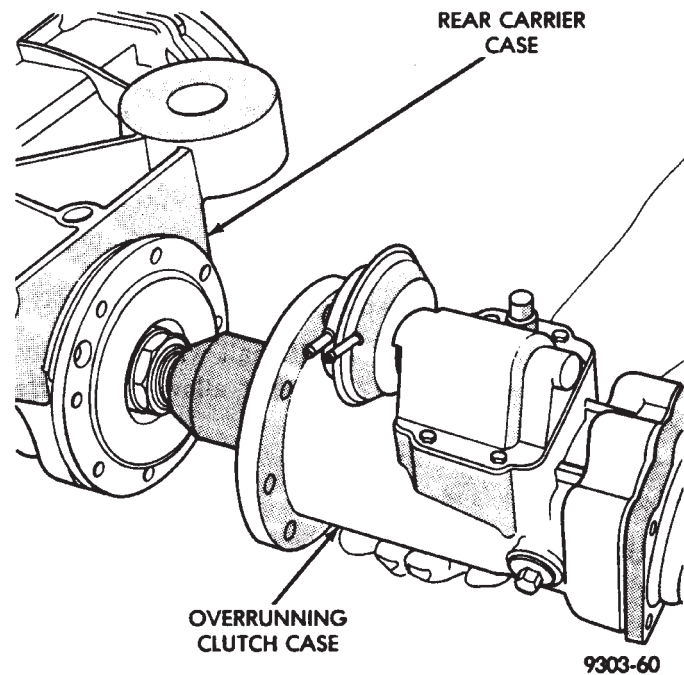
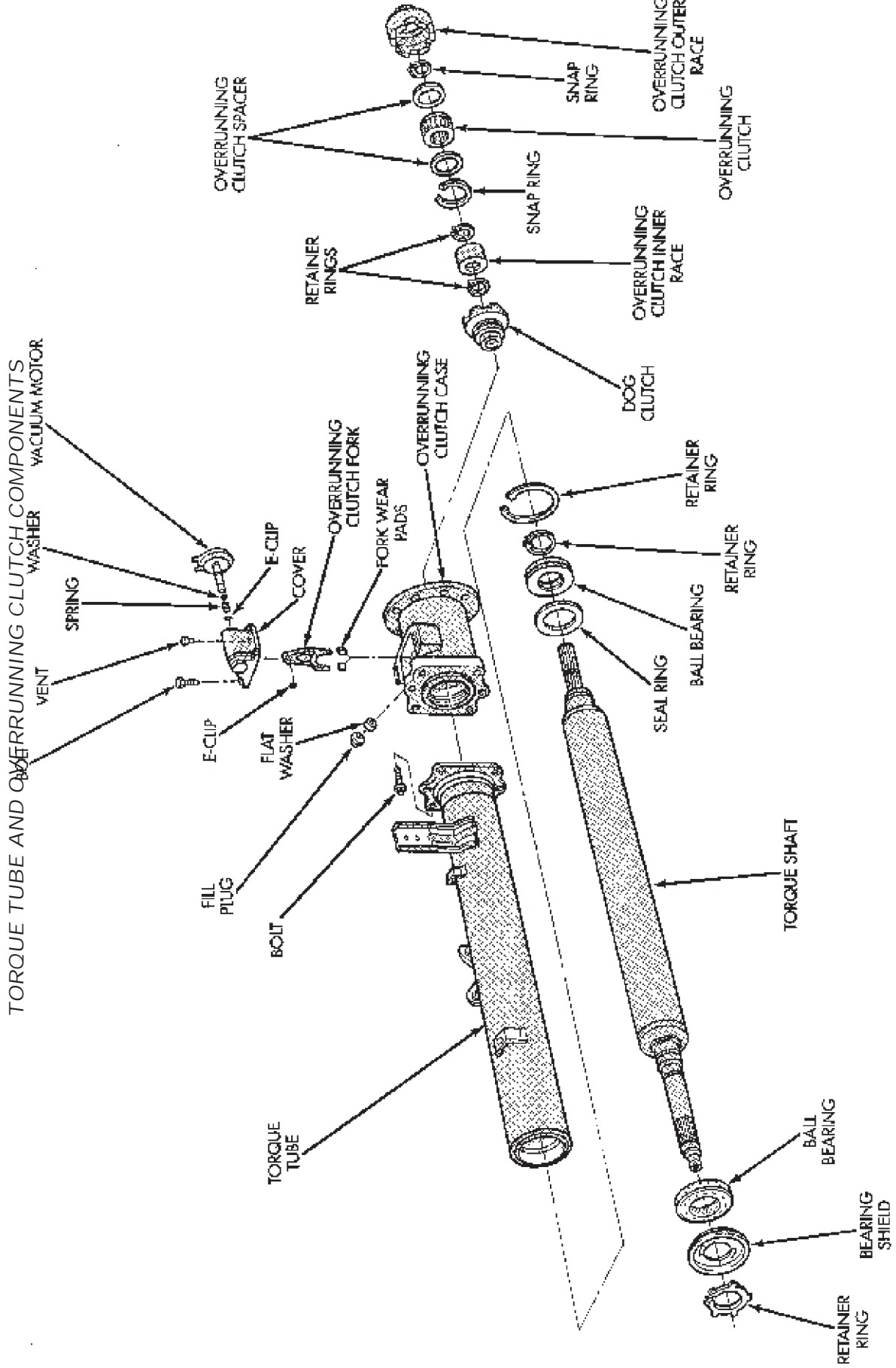

Fig. 6 Separate Rear Carrier Case from Overrunning Clutch Case

- (7) Reinstall rear drive line module assembly.
- (8) Check and fill fluid levels as required. Use only MOPAR® TYPE 7176 Automatic Transmission Fluid or equivalent in the overrunning clutch housing.



9303-38

TORQUE TUBE

REMOVAL AND INSTALLATION

- (1) Remove rear drive line module assembly from vehicle.
- (2) Remove viscous coupling.
- (3) Remove snap ring and torque tube bearing shield (Fig. 1).

CAUTION: Note the position that the snap ring was removed. The snap ring can be accidentally installed backwards. The snap ring is concave and the fingers on the snap ring must angle towards the bearing shield.

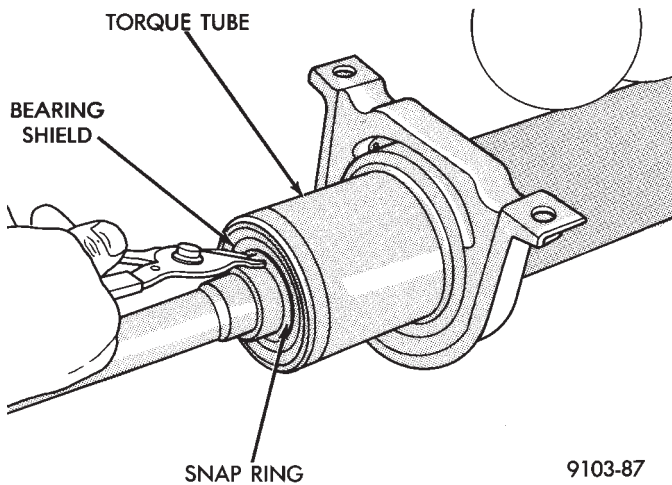

Fig. 1 Remove Torque Shaft Snap Ring and Bearing Shield

- (4) Remove torque tube to overrunning clutch case bolts (Fig 2).

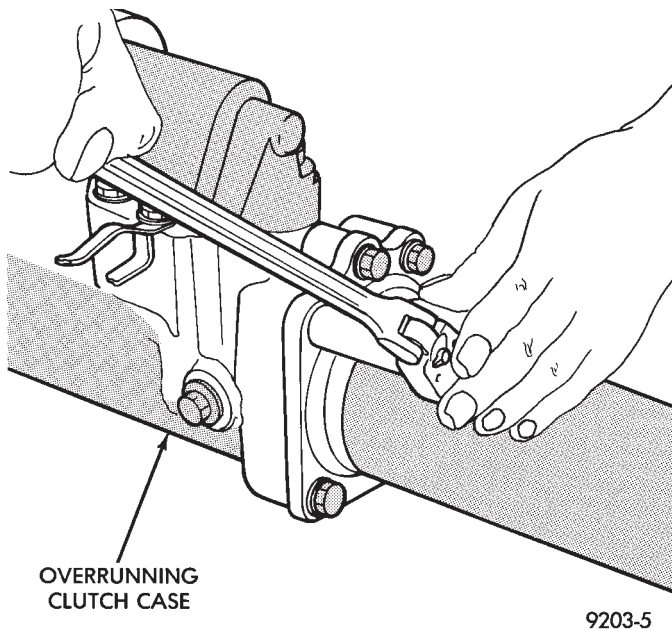

Fig. 2 Torque Tube Bolts

- (5) Slide torque tube off of torque shaft.

- (6) For Installation, Reverse Removal Procedure.

FRONT BEARING

REMOVAL AND INSTALLATION

The rear drive line module must be removed to service this bearing.

- (1) Remove rear drive line module assembly from vehicle.
- (2) Remove viscous coupling.
- (3) Remove overrunning clutch cover assembly.
- (4) Drain fluid from overrunning clutch case.
- (5) Remove overrunning clutch case to rear carrier case bolts (Fig. 3).

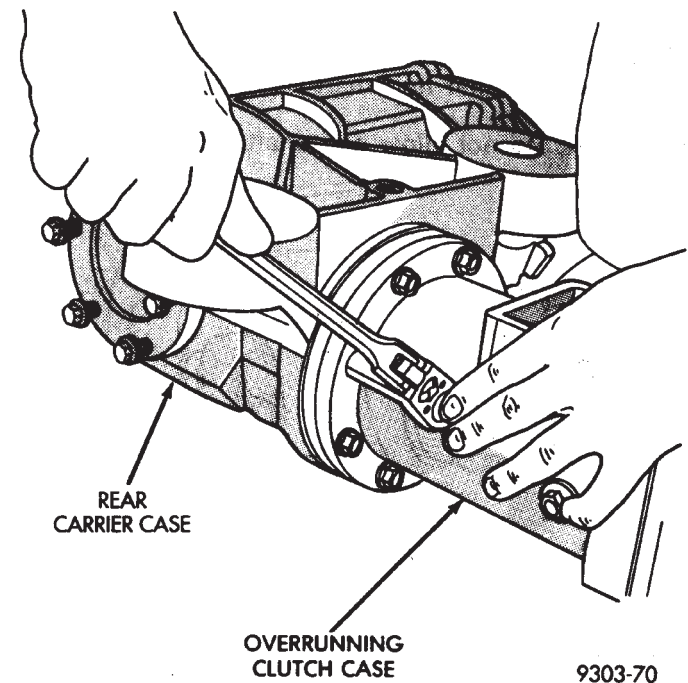

Fig. 3 Overrunning Clutch Housing to Rear carrier Bolts

- (6) Separate overrunning clutch case from differential carrier case (Fig. 4).
- (7) Remove overrunning clutch inner race snap ring (Fig. 5).
- (8) Slide overrunning clutch inner race off of shaft (Fig. 6).
- (9) Remove shaft snap ring and slide dog clutch off of the shaft.
- (10) Remove torque shaft rear bearing snap ring.
- (11) Remove overrunning case to torque tube bolts (Fig. 7).
- (12) Separate torque tube from overrunning clutch housing.

CAUTION: Note the position that the snap ring was removed. The snap ring can be accidentally installed backwards. The snap ring is concave and the fingers on the snap ring must angle towards the bearing shield.

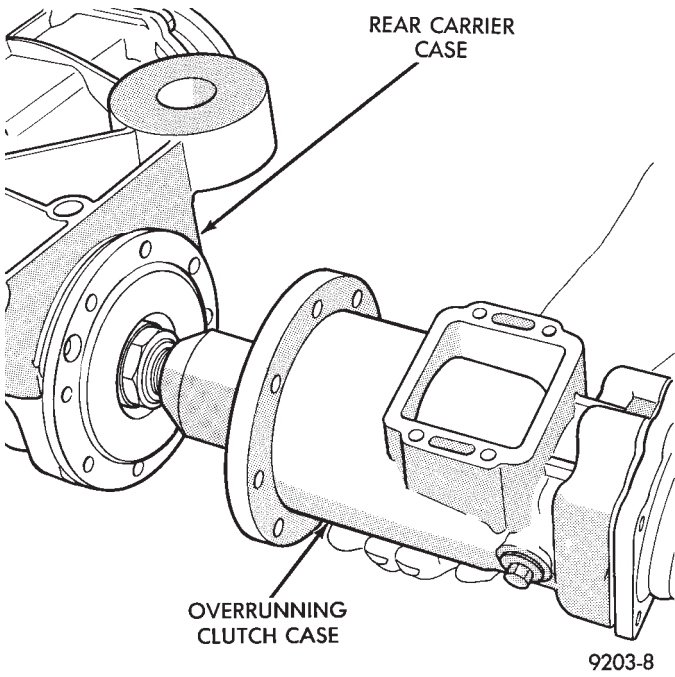

Fig. 4 Separate Rear Carrier case from overrunning clutch case

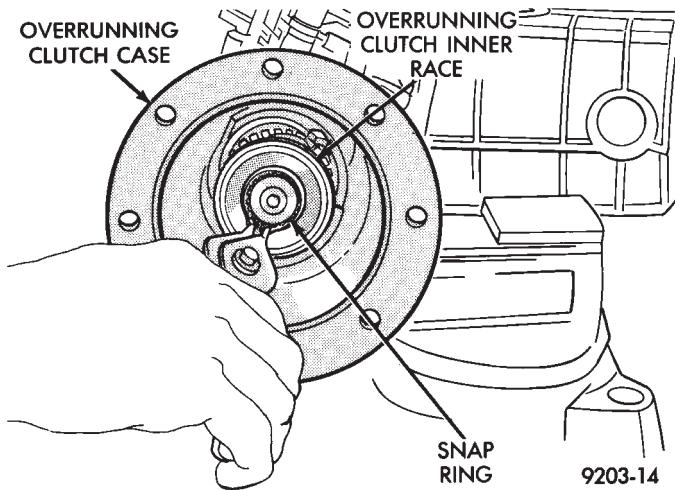

Fig. 5 Inner Race Snap Ring Removal

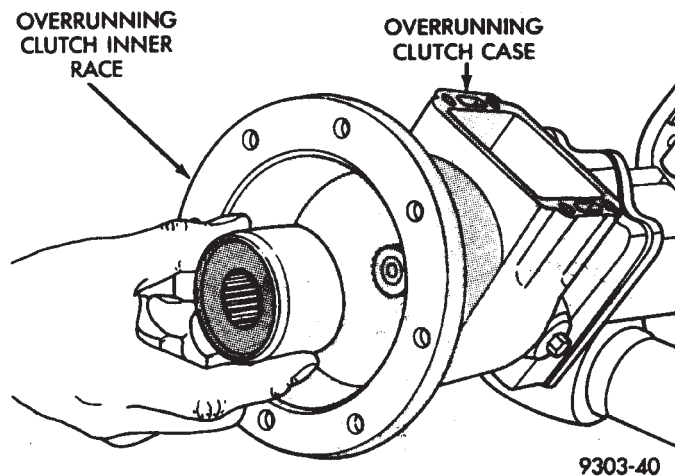

Fig. 6 Remove Overrunning Clutch Race

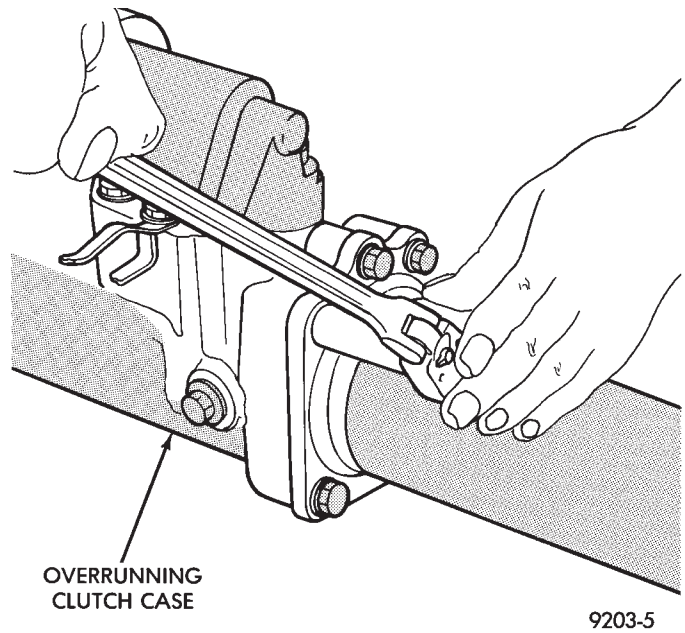

Fig. 7 Torque Tube Bolts

(13) Remove front snap ring and torque tube bearing shield (Fig. 8).

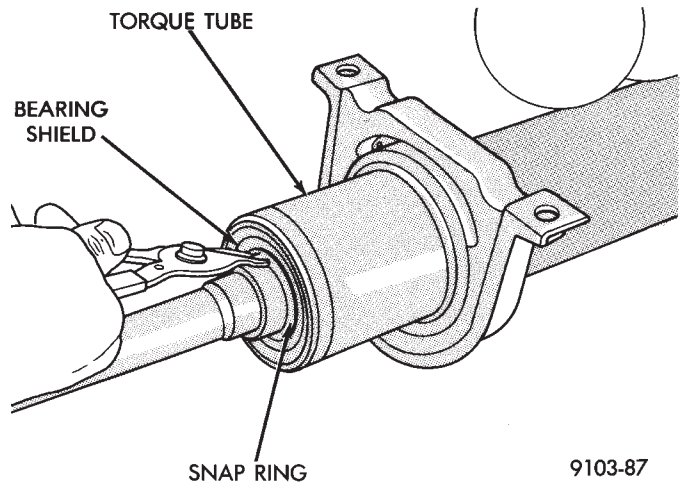

Fig. 8 Remove Torque Shaft Snap Ring and Shield

- (14) Slide shaft out of torque tube.
- (15) Drive bearing out of housing.
- (16) To Install Bearing, Reverse Removal Procedure.

REAR BEARING

REMOVAL AND INSTALLATION

The rear drive line module assembly must be removed to service this bearing.

- (1) Remove rear drive line module assembly from vehicle.
- (2) Remove viscous coupling unit.
- (3) Remove overrunning clutch cover assembly.
- (4) Drain fluid from overrunning clutch case.

- (5) Remove overrunning clutch case to differential carrier bolts.
- (6) Separate overrunning clutch case from differential carrier case.
- (7) Remove overrunning clutch inner race snap ring.
- (8) Slide overrunning clutch inner race off of shaft.
- (9) Remove shaft snap ring and slide dog clutch off of the shaft.
- (10) Remove torque shaft rear bearing inner snap ring.
- (11) Remove torque tube retaining bolts.
- (12) Separate overrunning clutch case from torque tube.
- (13) Remove rear bearing retaining snap ring in overrunning clutch case (Fig. 9).

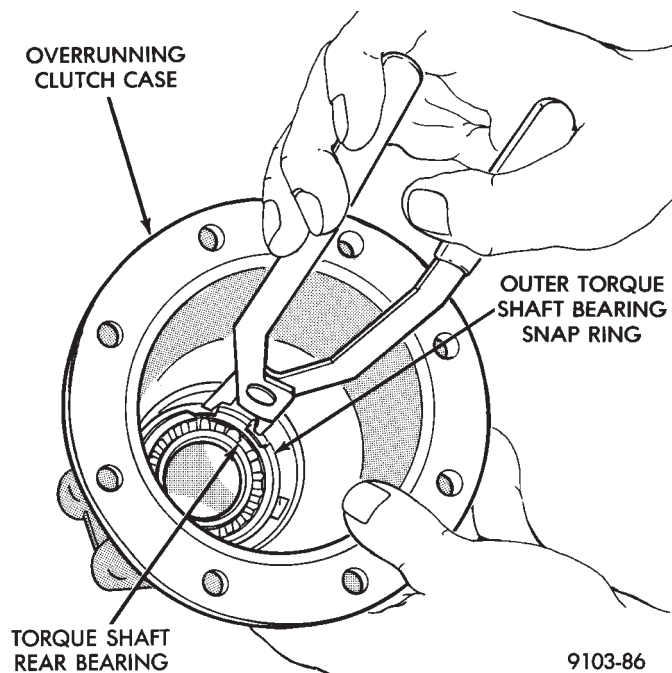

Fig. 9 Torque Shaft Rear Bearing Snap Ring

- (14) Remove rear torque shaft bearing.
- (15) To Install, Reverse Removal Procedure.

OVERRUNNING CLUTCH VACUUM MOTOR

REMOVAL

- (1) Remove rear drive line module assembly from vehicle.
- (2) Cut clamps and disconnect vacuum hose to vacuum motor.
- (3) Remove overrunning clutch cover assembly mounting bolts (Fig. 1).
- (4) Lift overrunning clutch cover assembly off of overrunning clutch case.
- (5) Clamp assembly in soft jawed vise (Fig. 2).
- (6) Remove two E-clips from vacuum motor shaft (Fig. 3).

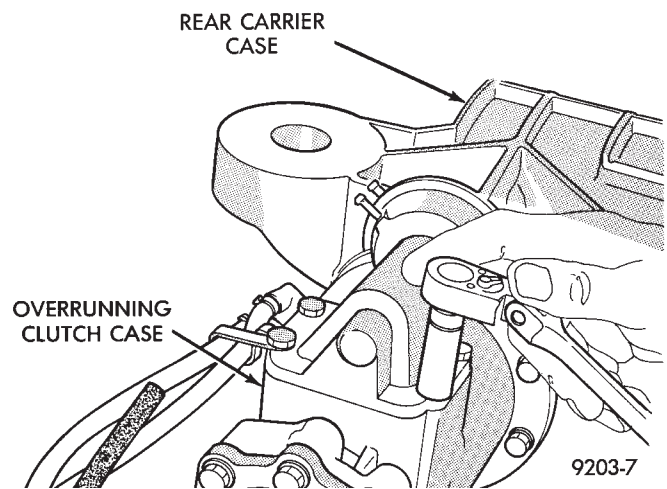

Fig. 1 Mounting Bolts

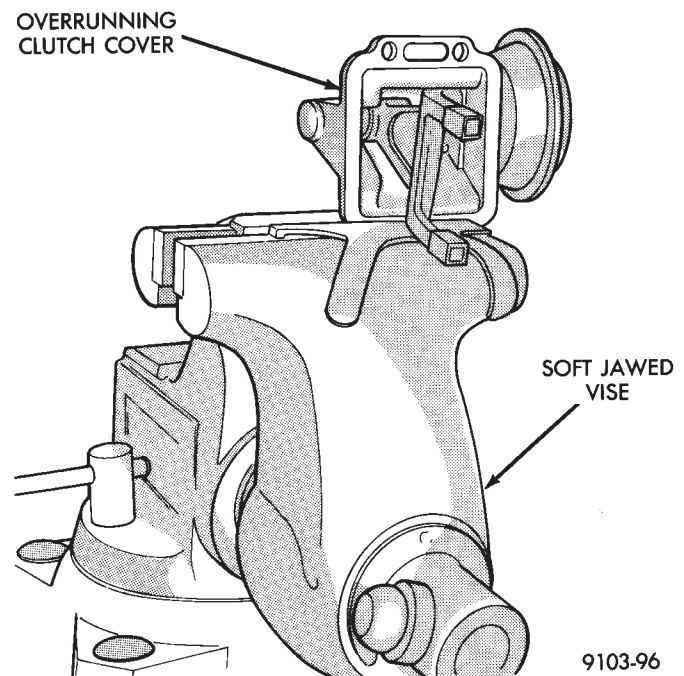

Fig. 2 Clamp Housing in Vise

- (7) Holding the overrunning clutch shift fork, slide shift motor out of housing (Fig. 4).

CAUTION: Shift fork can be installed backwards. Note its position before removing.

- (8) Clean and inspect all parts and sealing surfaces. Replace worn or damaged parts.

INSTALLATION

- (1) Slide vacuum shift motor into housing and through shift fork. Shift fork off set must be angle away from vacuum motor (Fig. 5).
- (2) Install two E-clips. One onto vacuum shift motor shaft and one on the vacuum motor bushing.
- (3) Apply Mopar® Gasket Maker, Loctite Gasket Eliminator or equivalent and reinstall cover. When

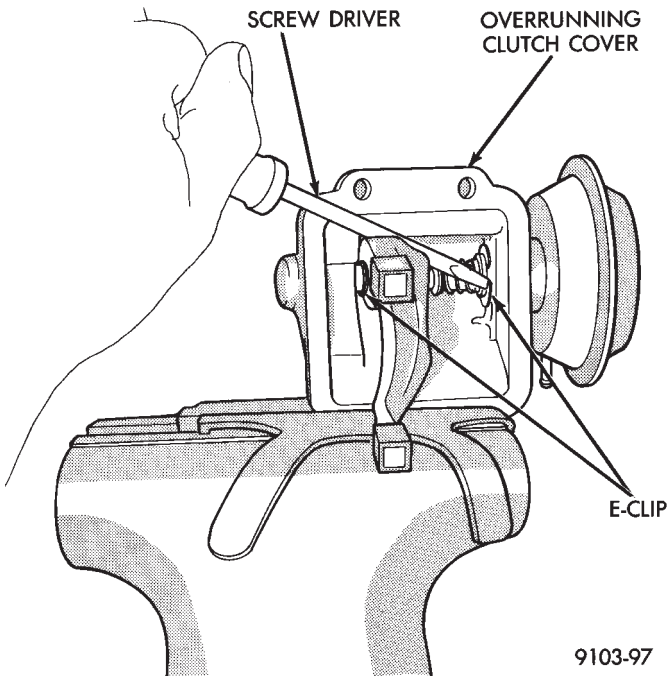

Fig. 3 Remove Two E-Clips

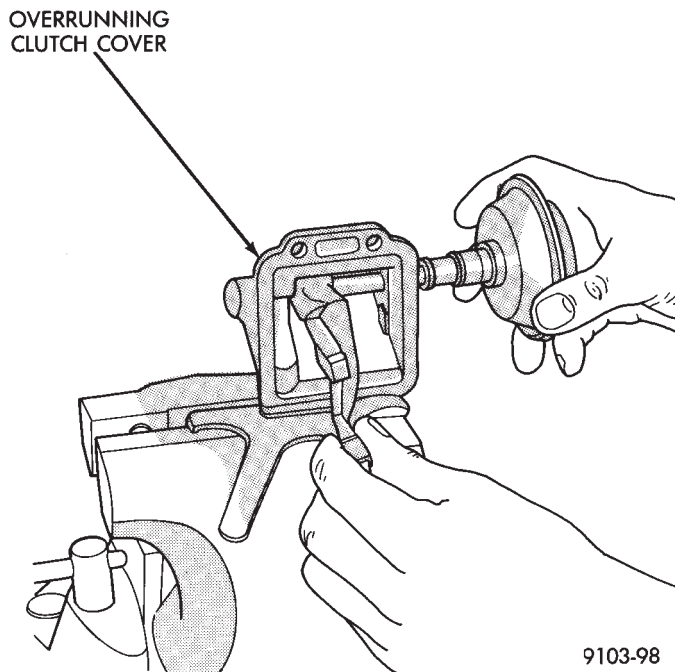

Fig. 4 Shift Fork Removal

installing cover be sure that the overrunning clutch fork engages into the overrunning clutch dog.

(4) Install overrunning clutch cover assembly mounting bolts and tighten bolts to 28 N•m (250 in. lbs.). Replace hose clamps.

(5) Reinstall rear drive line assembly into vehicle.

(6) Check and fill fluid levels as required.

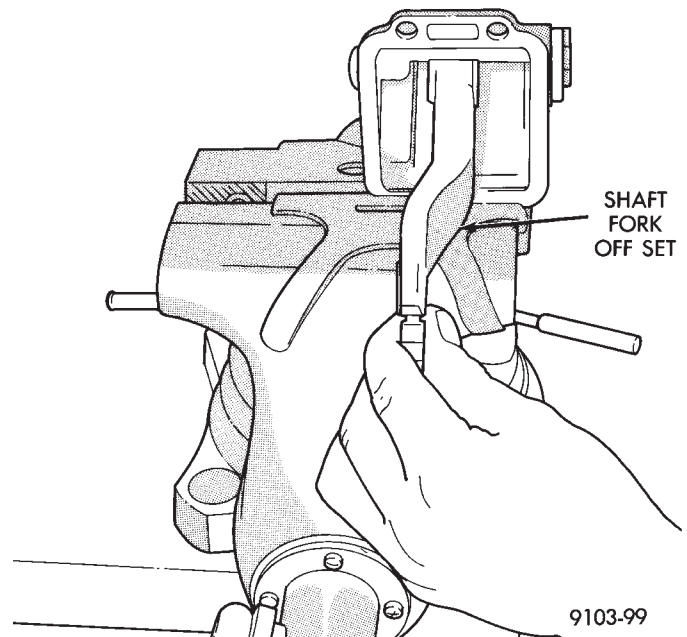

Fig. 5 Shift Fork Position

OVERRUNNING CLUTCH

REMOVAL

- (1) Remove rear drive line module assembly.
- (2) Remove overrunning clutch cover assembly.
- (3) Drain fluid from overrunning clutch case.
- (4) Remove overrunning clutch case to rear carrier case bolts (Fig 6).

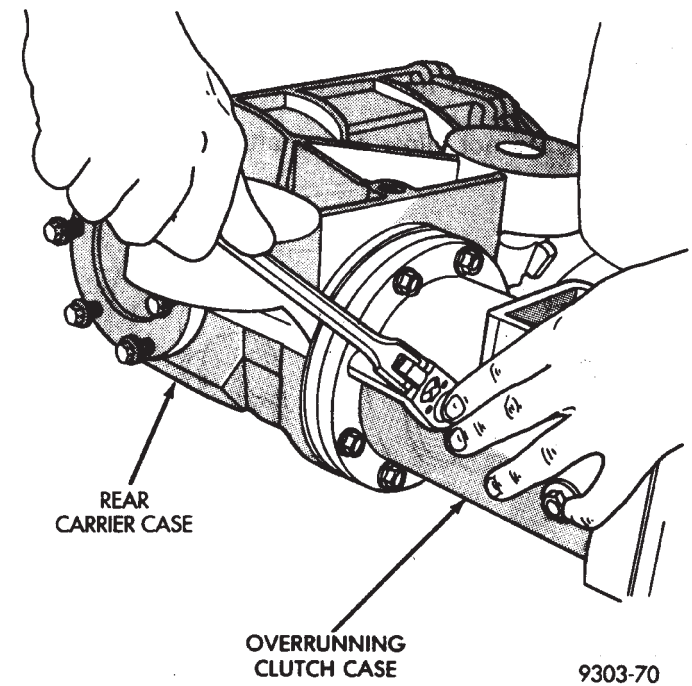

Fig. 6 Overrunning Clutch Case to Rear Carrier Bolts



(5) Separate the overrunning clutch case from the rear carrier case (Fig. 7).

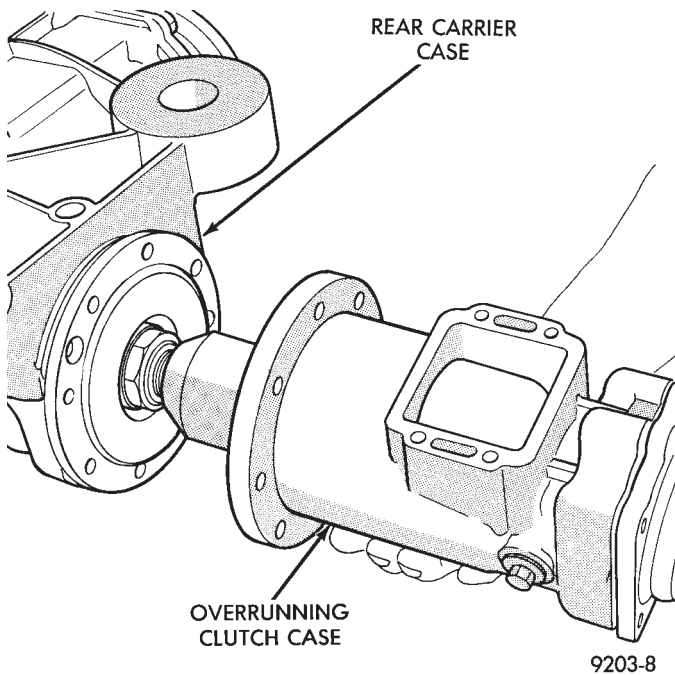

Fig. 7 Separate Rear Carrier Case from Overrunning Clutch Case

(6) Remove overrunning clutch snap ring (Fig. 8).

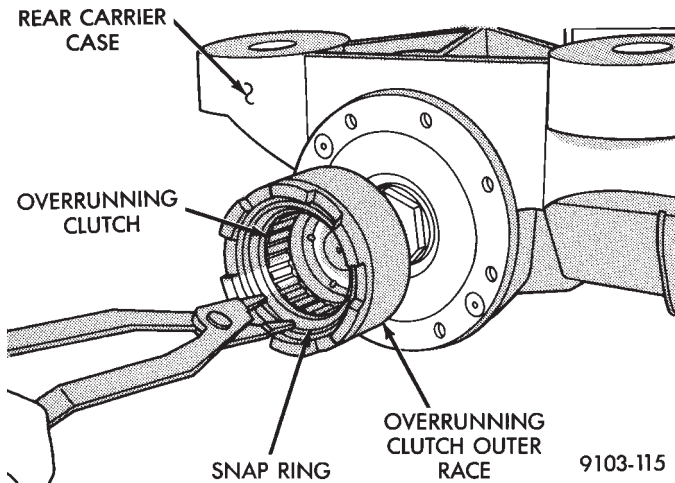

Fig. 8 Overrunning Clutch Snap Ring

(7) Remove spacers and overrunning clutch. Overrunning clutch can be installed backwards. Keep the spacers and overrunning clutch in order when taking the unit apart (Fig. 9).

(8) Remove overrunning clutch outer race snap ring (Fig. 10).

(9) Slide overrunning clutch outer race off of shaft (Fig. 11).

(10) Remove overrunning clutch inner race snap ring (Fig. 12).

(11) Slide overrunning clutch inner race off of the shaft (Fig. 13).

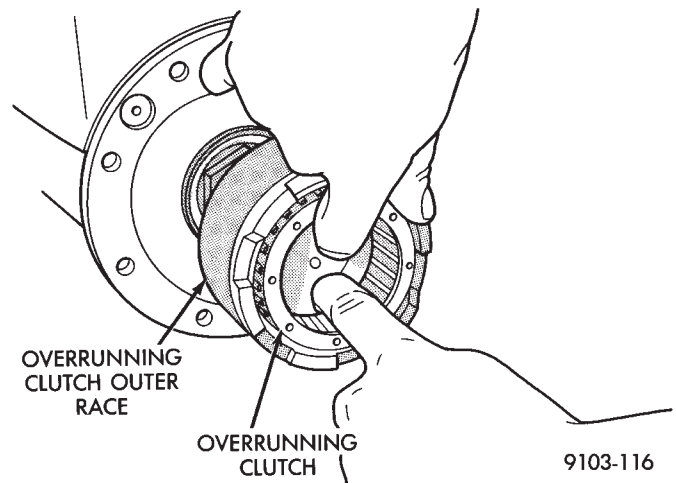

Fig. 9 Overrunning Clutch Removal

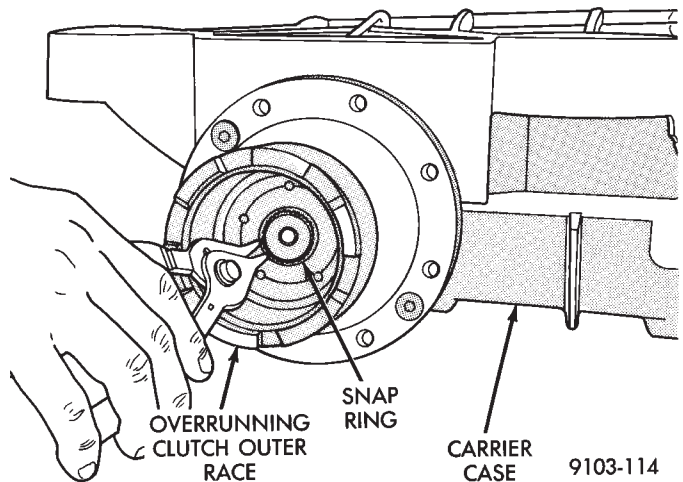

Fig. 10 Overrunning Clutch Snap Ring Removal

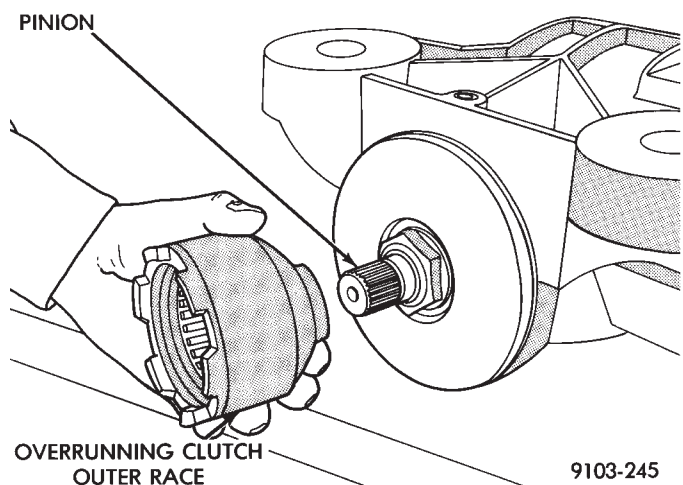

Fig. 11 Overrunning Clutch Outer Race Removal

(12) Remove dog-clutch snap ring (Fig. 14).

(13) Slide dog-clutch off of the shaft (Fig. 15).

(14) Clean and inspect all parts. Replace worn or damaged parts.

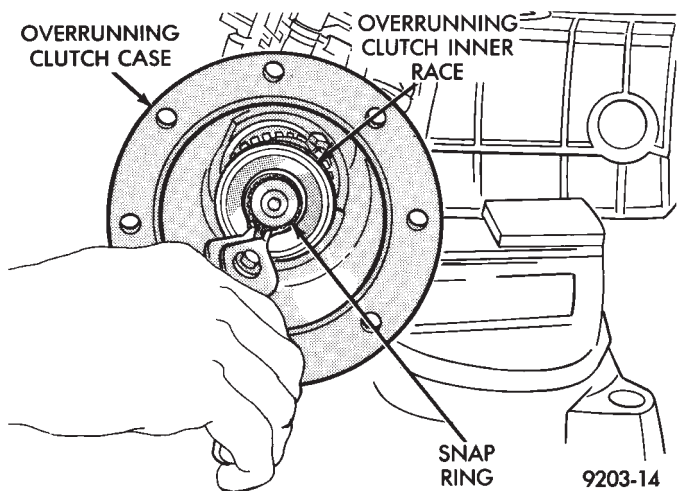

Fig. 12 Inner Race Snap Ring Removal

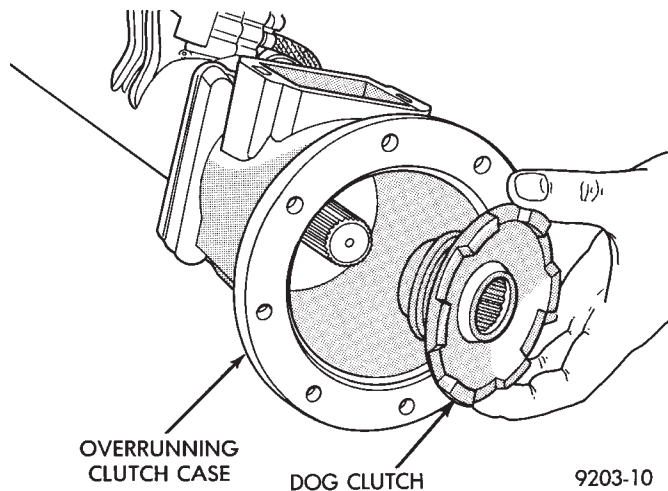

Fig. 15 Dog Clutch Removal

CAUTION: The overrunning clutch can be installed backwards.

(3) To check for proper installation of the overrunning clutch, temporarily install the inner race into the overrunning clutch. The tapered end must go in first (Fig. 16). The inner race should spin when turned counterclockwise (Fig. 17) and grab when turned clockwise (Fig. 18).

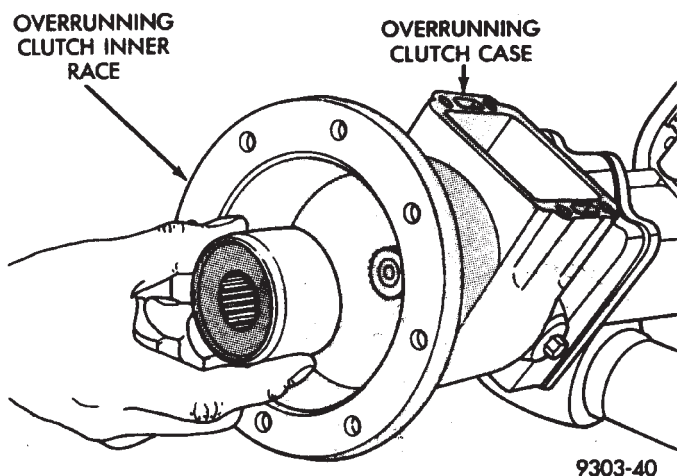

Fig. 13 Remove Overrunning Clutch Race

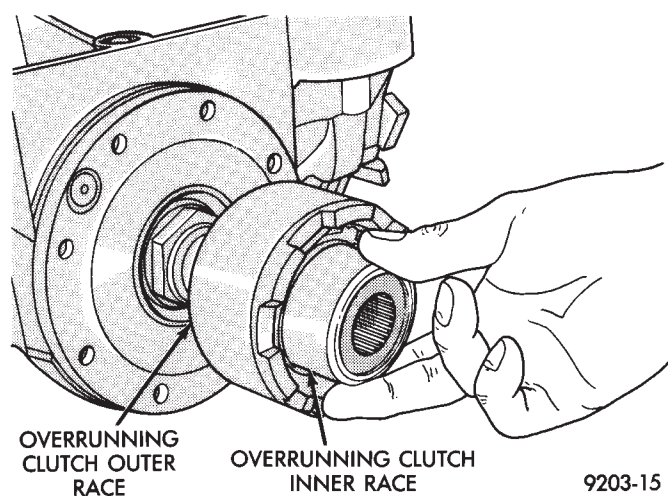

Fig. 16 Temporarily Install Inner Race

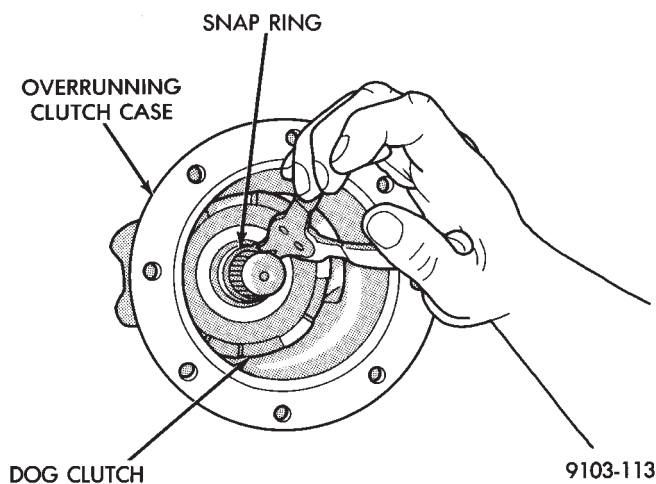

Fig. 14 Dog Clutch Snap Ring

INSTALLATION

- (1) Install outer overrunning clutch race and retaining snap ring.
- (2) Install overrunning clutch spacers and snap ring.

(4) Install dog clutch onto shaft and reinstall snap ring.

(5) Install overrunning clutch on the shaft with the tapered end facing outward and install snap ring.

(6) Clean all sealing surfaces. Apply a bead of Mopar® Gasket Maker, Loctite Gasket Eliminator or equivalent. Then reinstall the overrunning clutch case to the rear carrier case. Install retaining bolts and tighten to 28 N•m (250 in. lbs.).

(7) Apply Mopar® Gasket Maker, Loctite Gasket Eliminator or equivalent and reinstall cover. When installing cover be sure that the overrunning clutch fork engages into the overrunning dog clutch.

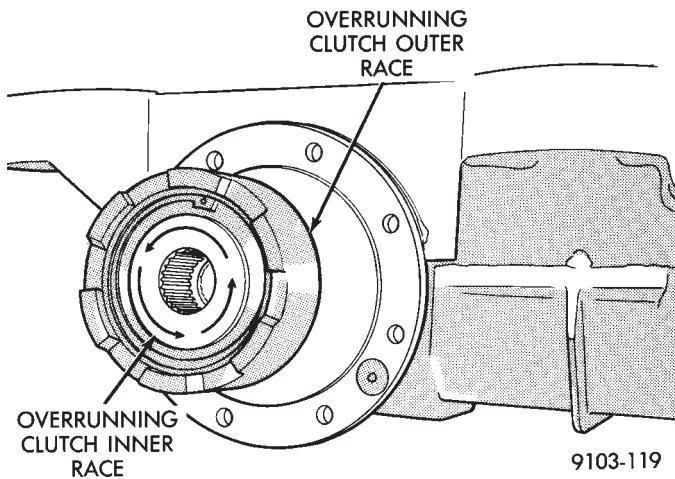

Fig. 17 Turn Inner Race Counterclockwise

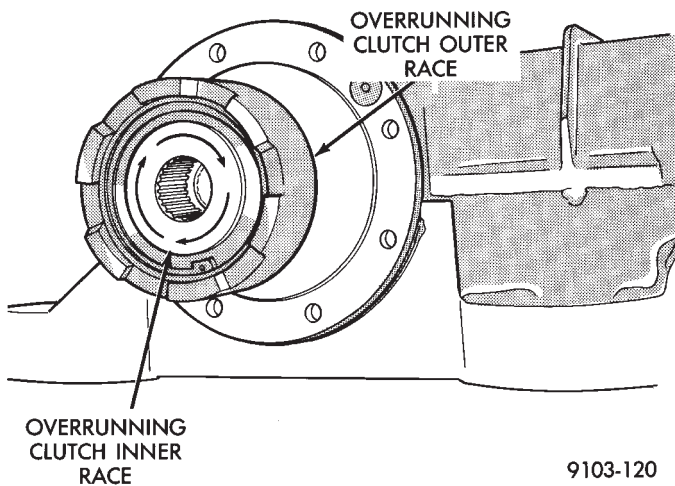

Fig. 18 Turn Inner Race Clockwise

(8) Install rear drive line module assembly into the vehicle.

(9) Check and fill fluid levels as required.

OVERRUNNING CLUTCH CASE

REMOVAL

- (1) Remove rear drive line module assembly.
- (2) Remove overrunning clutch cover assembly.
- (3) Drain fluid from overrunning clutch case.
- (4) Remove overrunning clutch case to rear carrier case bolts (Fig. 19).
- (5) Separate the overrunning clutch housing from the rear carrier case.
- (6) Remove overrunning clutch inner race snap ring (Fig. 20).
- (7) Slide overrunning clutch inner race off of the shaft.
- (8) Remove dog-clutch snap ring and slide dog-clutch off of the shaft.
- (9) Remove torque shaft rear bearing snap ring.
- (10) Remove torque tube retaining bolts (Fig. 21).

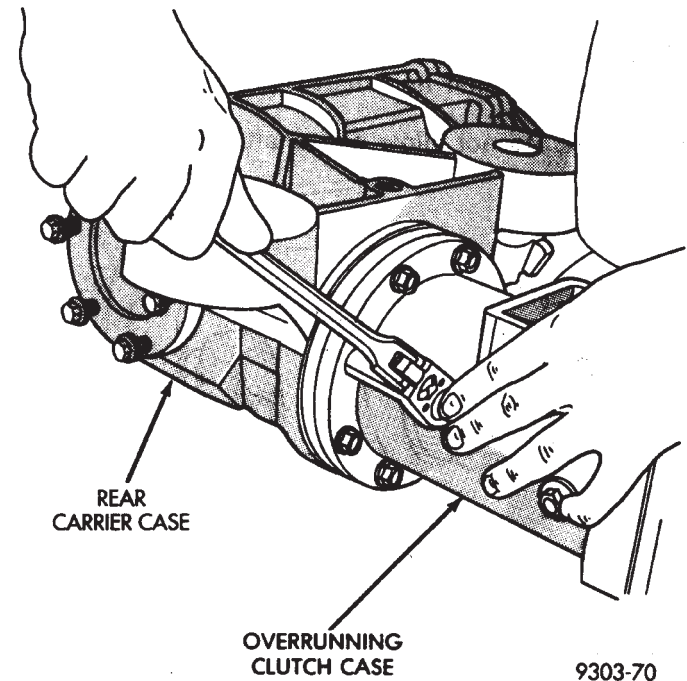

Fig. 19 Overrunning Clutch Case to Rear Carrier Bolts

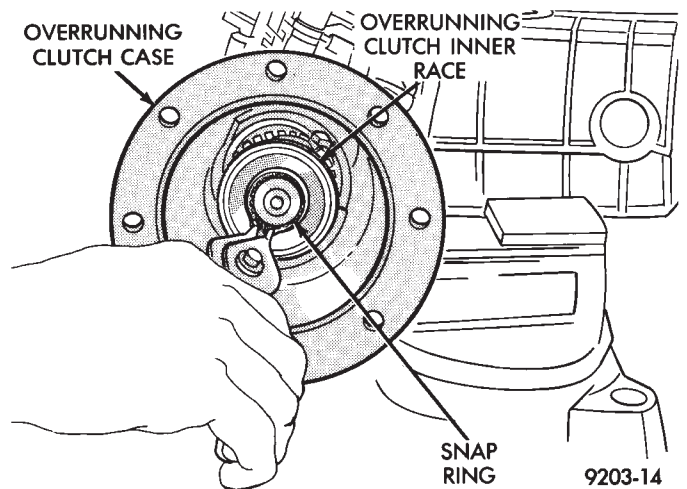

Fig. 20 Inner Race Snap Ring

(11) Separate overrunning clutch case from torque tube.

(12) Remove rear bearing retaining snap ring in overrunning clutch case (Fig. 22).

(13) Remove rear torque shaft bearing.

(14) Drive out front overrunning clutch seal with special tool C-4967 (Fig. 23).

INSTALLATION

(1) Install new seal with special tool MD998334. Seal should be flush with outside edge of housing (Fig. 24).

(2) Install rear torque shaft bearing and snap ring.

(3) Install overrunning clutch case onto torque tube. Tighten bolts to 28 N•m (250 in. lbs.).

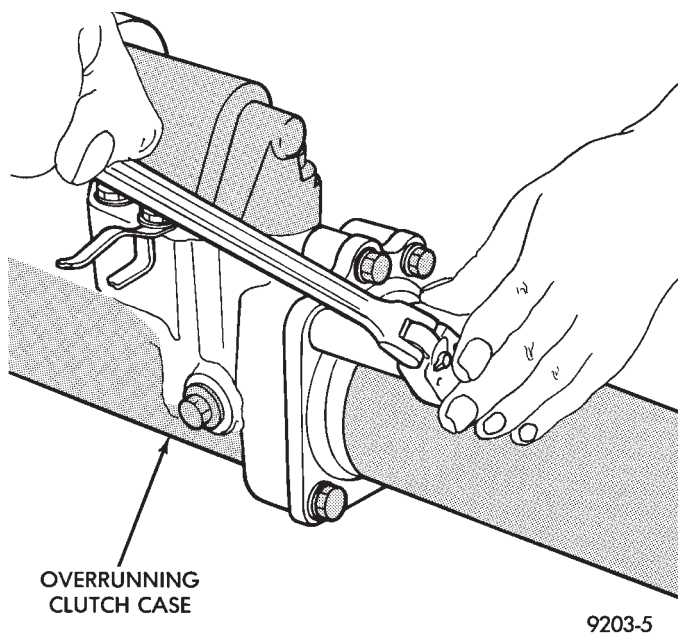

Fig. 21 Torque Tube Bolts

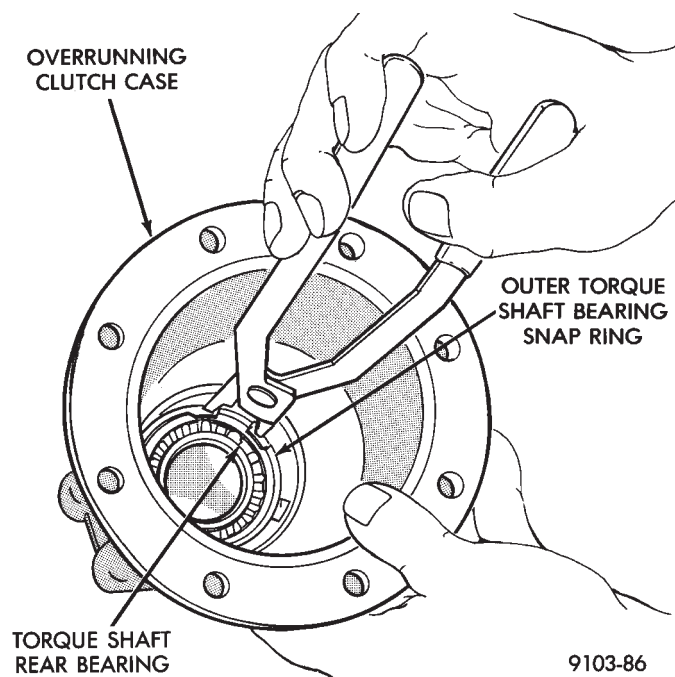

Fig. 22 Torque Shaft Rear Bearing Snap Ring

- (4) Install torque shaft snap ring.
- (5) Slide dog clutch onto shaft and install snap ring.
- (6) Slide overrunning clutch inner race onto shaft and install retaining snap ring.
- (7) Clean all sealing surfaces. Then apply a bead of Mopar® Gasket Maker, Loctite Gasket Eliminator or equivalent. Then reinstall the overrunning clutch case to the rear carrier case. Install retaining bolts and tighten to 28 N•m (250 in. lbs.).
- (8) Apply Mopar® Gasket Maker, Loctite Gasket Eliminator or equivalent and reinstall vacuum shift

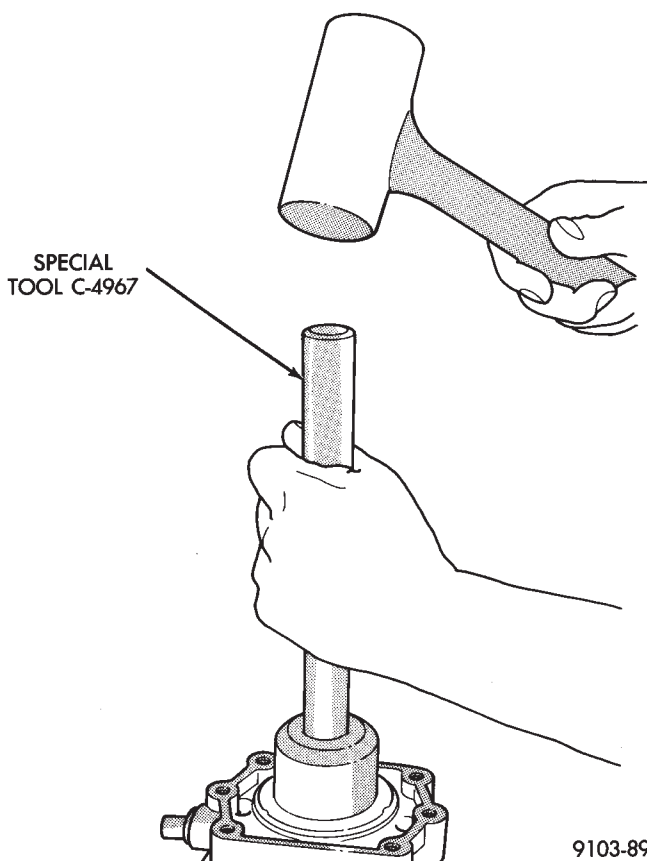

Fig. 23 Seal Removal

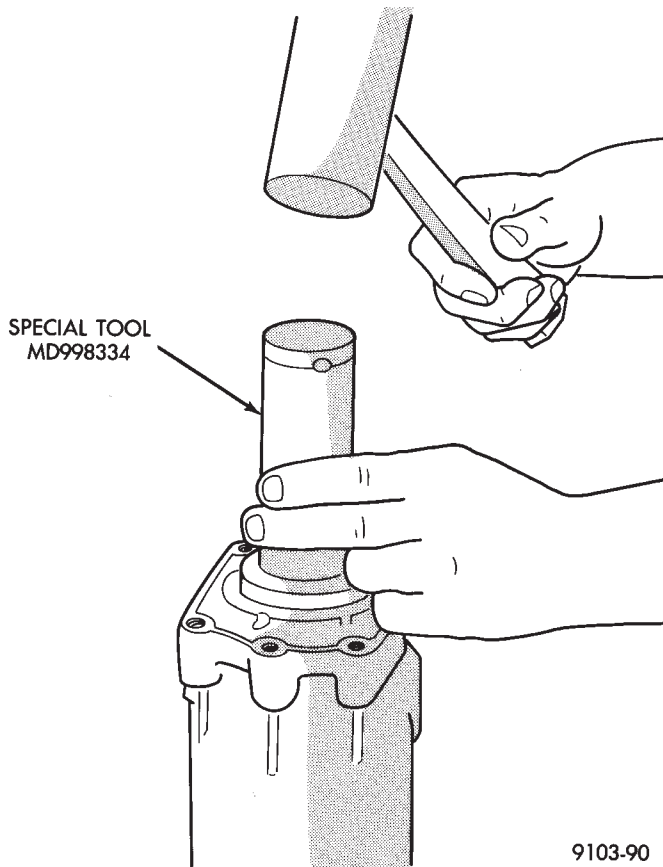

Fig. 24 Installing New Seal

cover. When installing cover be sure that the over-running clutch fork engages into the overrunning dog clutch.

- (9) Install rear drive line module into vehicle.
- (10) Check and fill all fluid levels as required.

PROPELLER SHAFT SERVICE

The propeller shaft is a hollow shaft. It has a plunging tripod joint on the front of the shaft and a fixed tripod joint on the rear of the shaft. There are no serviceable parts. The shaft is serviced as an assembly. The flange patterns are different at each end to prevent installing the shaft backwards.

REMOVAL AND INSTALLATION

- (1) Place vehicle in neutral and lift vehicle on hoist.

CAUTION: Do not allow end of propeller shaft to hang free.

- (2) Remove propeller shaft rear mounting bolts and support end of propeller shaft (Fig. 1).

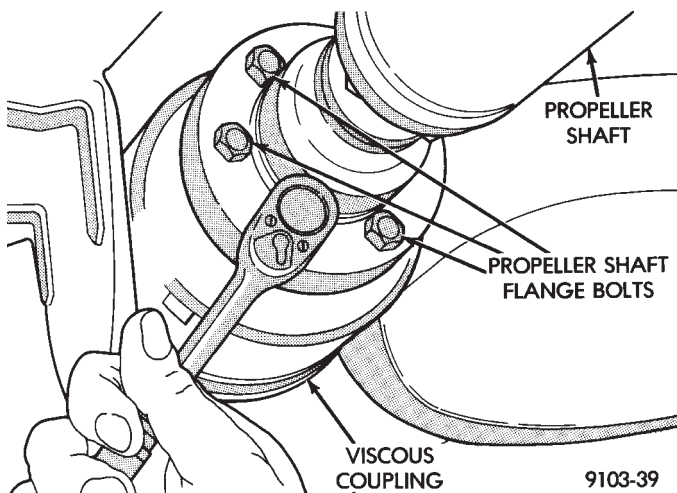

Fig. 1 Propeller Shaft Mounting Bolts (Rear)

- (3) Remove propeller shaft front mounting bolts and remove propeller shaft assembly (Fig. 2)

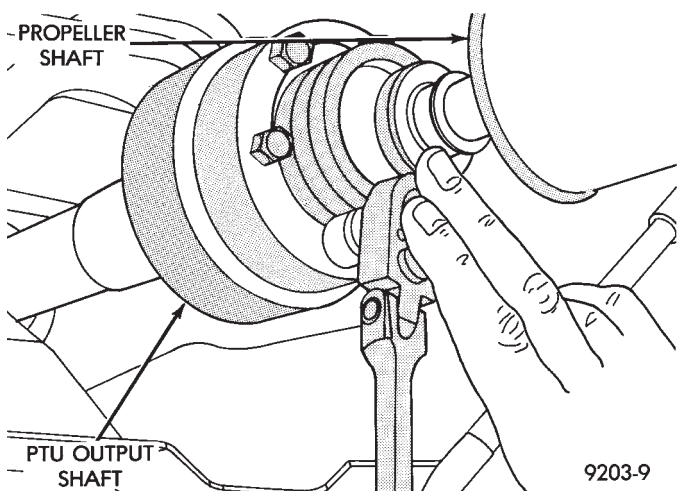

Fig. 2 Propeller Shaft Bolts (Front)

CAUTION: Do not allow the propeller shaft to hang freely while installing.

- (4) To Install, Reverse Removal Procedure. Be sure flange mating faces are clean.

HALF SHAFT SERVICE

The half shaft assemblies are three piece units. Each half shaft has one tripod joint at each end and a solid interconnecting shaft. The procedure to recondition the inner or outer joint is identical.

Note that lubricant requirements and quantities could be different than other axle shaft joints located on the vehicle. Only use the correct lubricant and amount supplied with the boot package or joint. Do not use standard wheel bearing grease or other lubricants, joint failure will result.

REMOVAL AND INSTALLATION

- (1) Lift vehicle on hoist so that the wheels hang freely.
- (2) Remove rear wheel.
- (3) Remove cotter pin, nut lock and spring washer (Fig. 3).

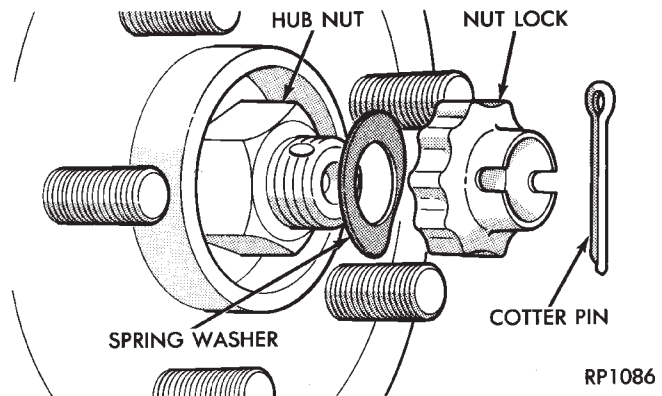

Fig. 3 Cotter Pin, Nut Lock, and Spring Washer

- (4) Remove hub nut and washer.

CAUTION: The half shaft outer C.V. joint, when installed, acts as a bolt and secures the hub/bearing assembly. If the vehicle is to be supported or moved on its wheels, install and torque a bolt through the hub. This will insure that the hub/bearing assembly cannot loosen.

- (5) Remove inner half shaft retaining bolts (Fig. 4).
- (6) The half shaft is spring loaded. Compress inner half shaft joint slightly and pull downward to clear rear differential. Then pull half shaft assembly outward to remove (Fig. 5).
- (7) For Installation, Reverse Removal Procedure.

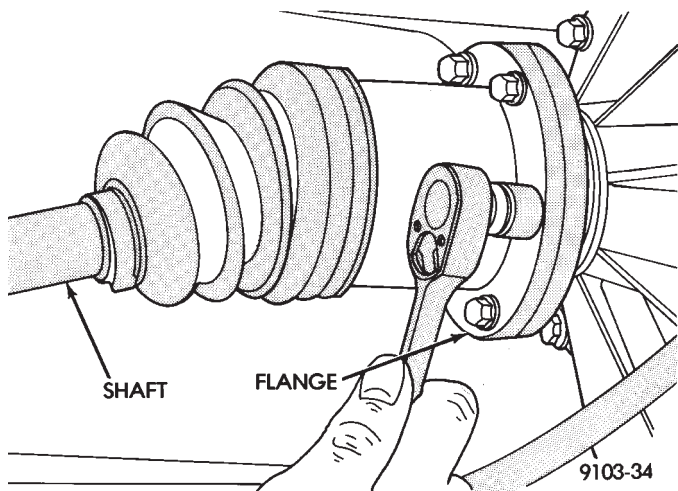

Fig. 4 Inner Half Shaft Bolts

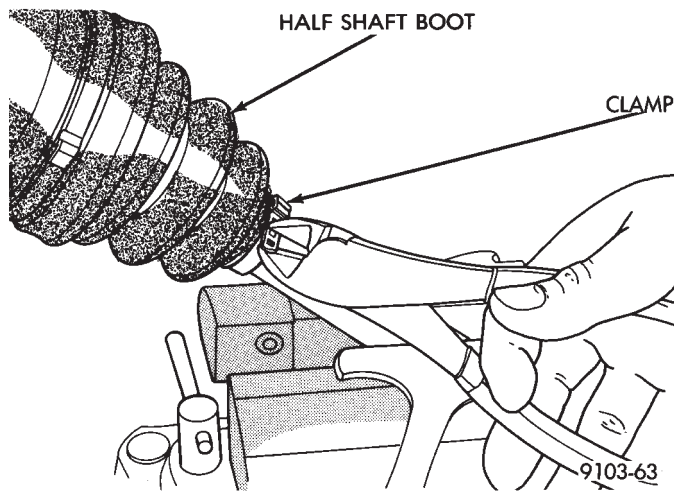

Fig. 2 Remove Boot Clamps

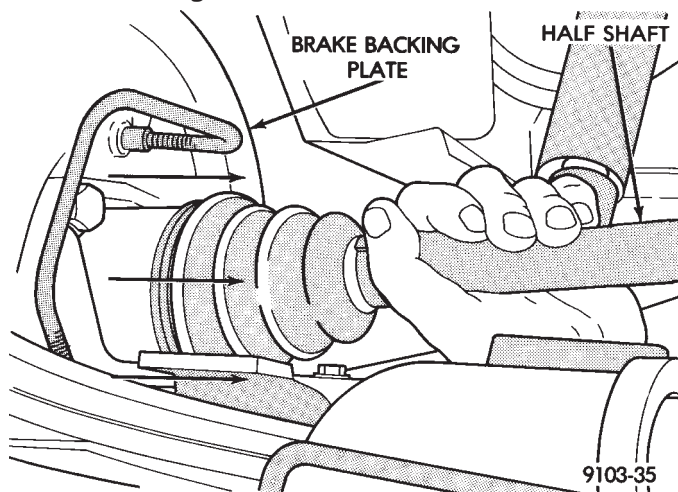

Fig. 5 Half Shaft Removal

REAR HALF SHAFT JOINT/BOOT REPLACEMENT

(1) Remove half shaft from vehicle. Refer to Half Shaft Service in this section for removal procedure.

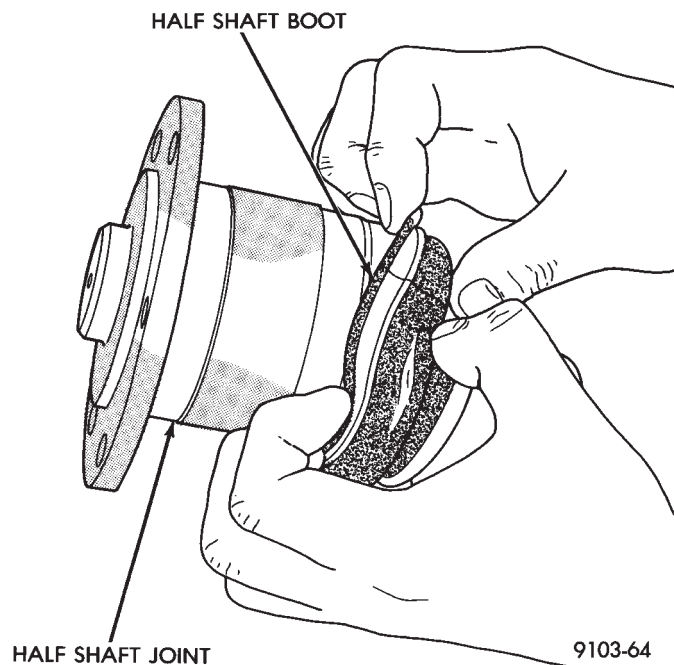

Fig. 3 Pull Back Boot

Clean and inspect all parts for wear or damage, replace any worn or damaged parts.
To Install, Reverse Removal Procedure.

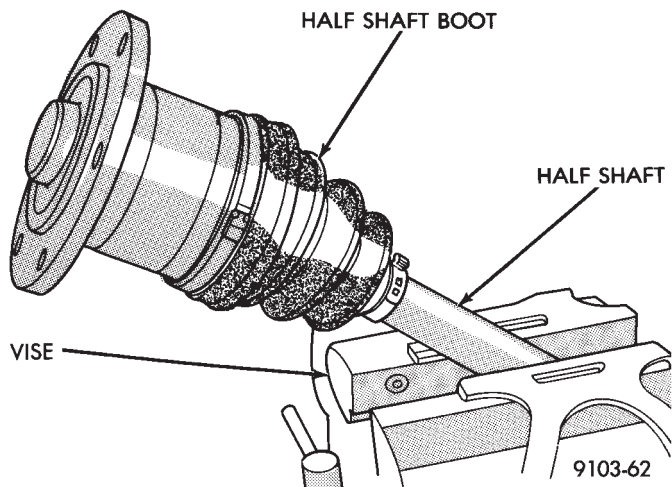

Fig. 1 Clamp Shaft in Soft Jawed Vice

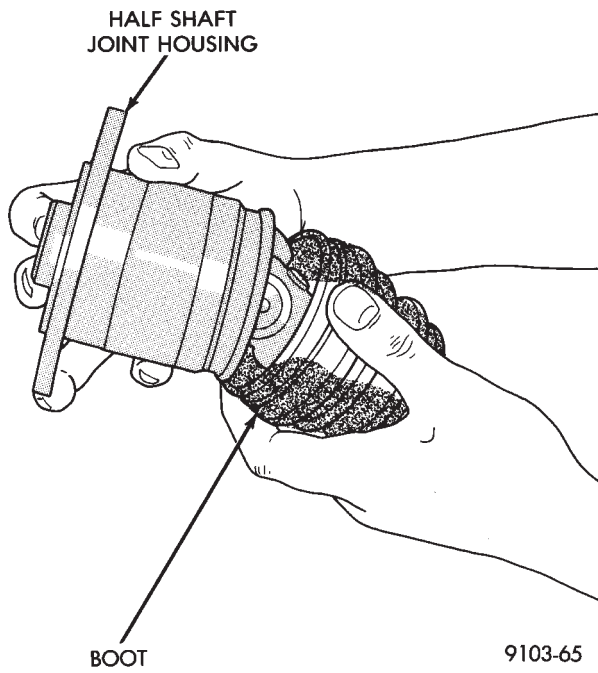

Fig. 4 Remove Housing

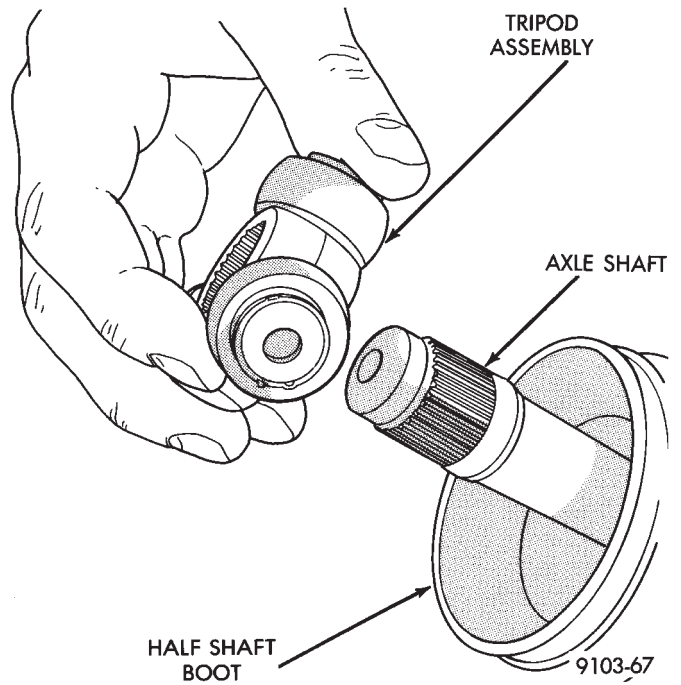

Fig. 6 Slide Tripod Off the Shaft

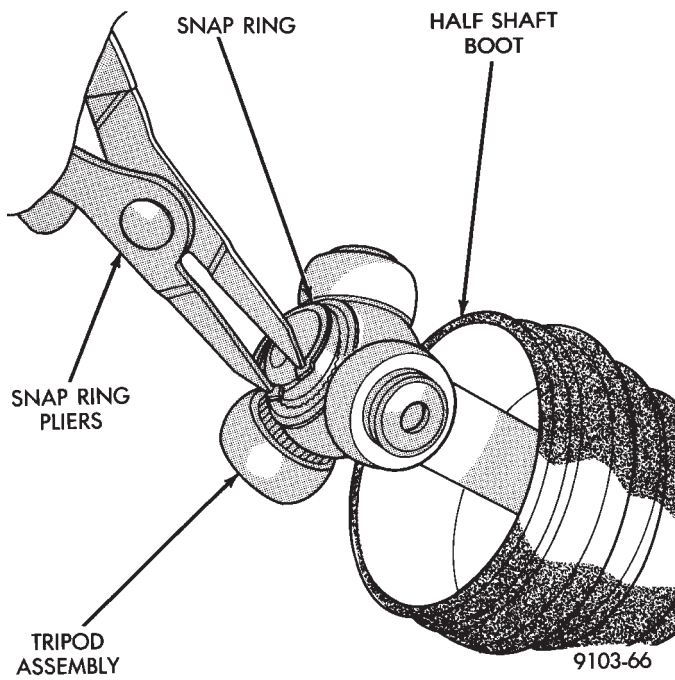

Fig. 5 Remove Snap Ring

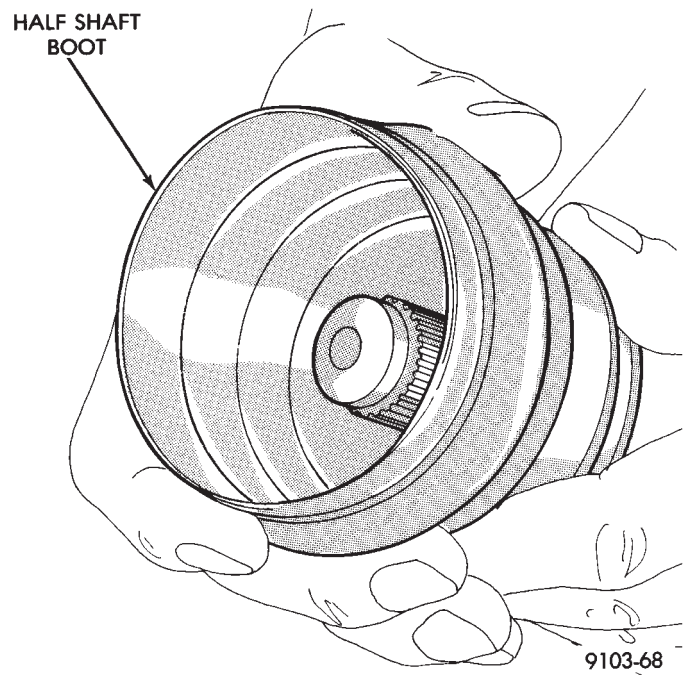
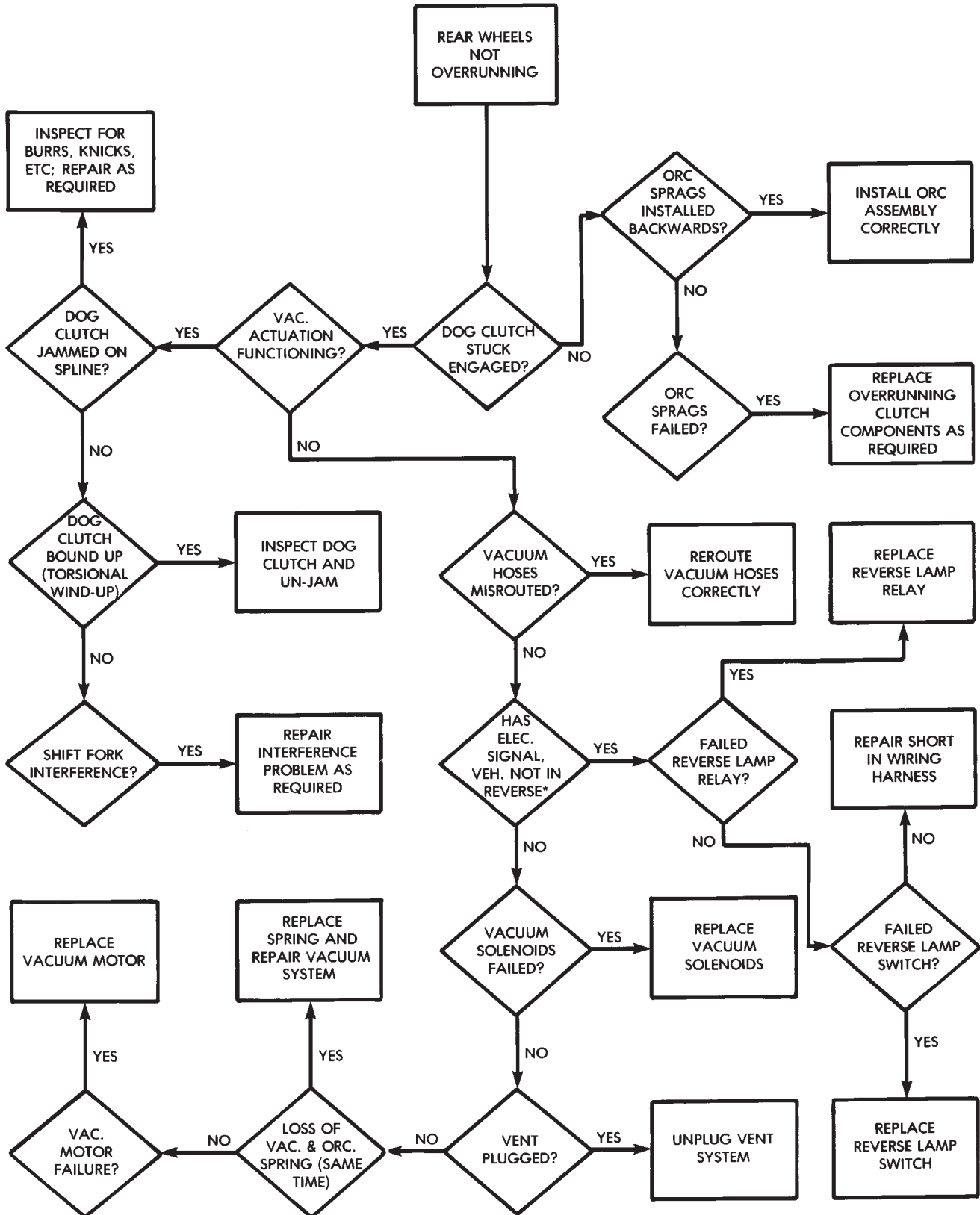

Fig. 7 Remove Boot

REAR DRIVE LINE MODULE VACUUM ACTUATION DIAGNOSIS

REAR WHEELS NOT OVERRUNNING



*TO DRIVELINE SOLENOIDS



NO ALL WHEEL DRIVE, REVERSE ONLY; PROPELLER SHAFT TURNING

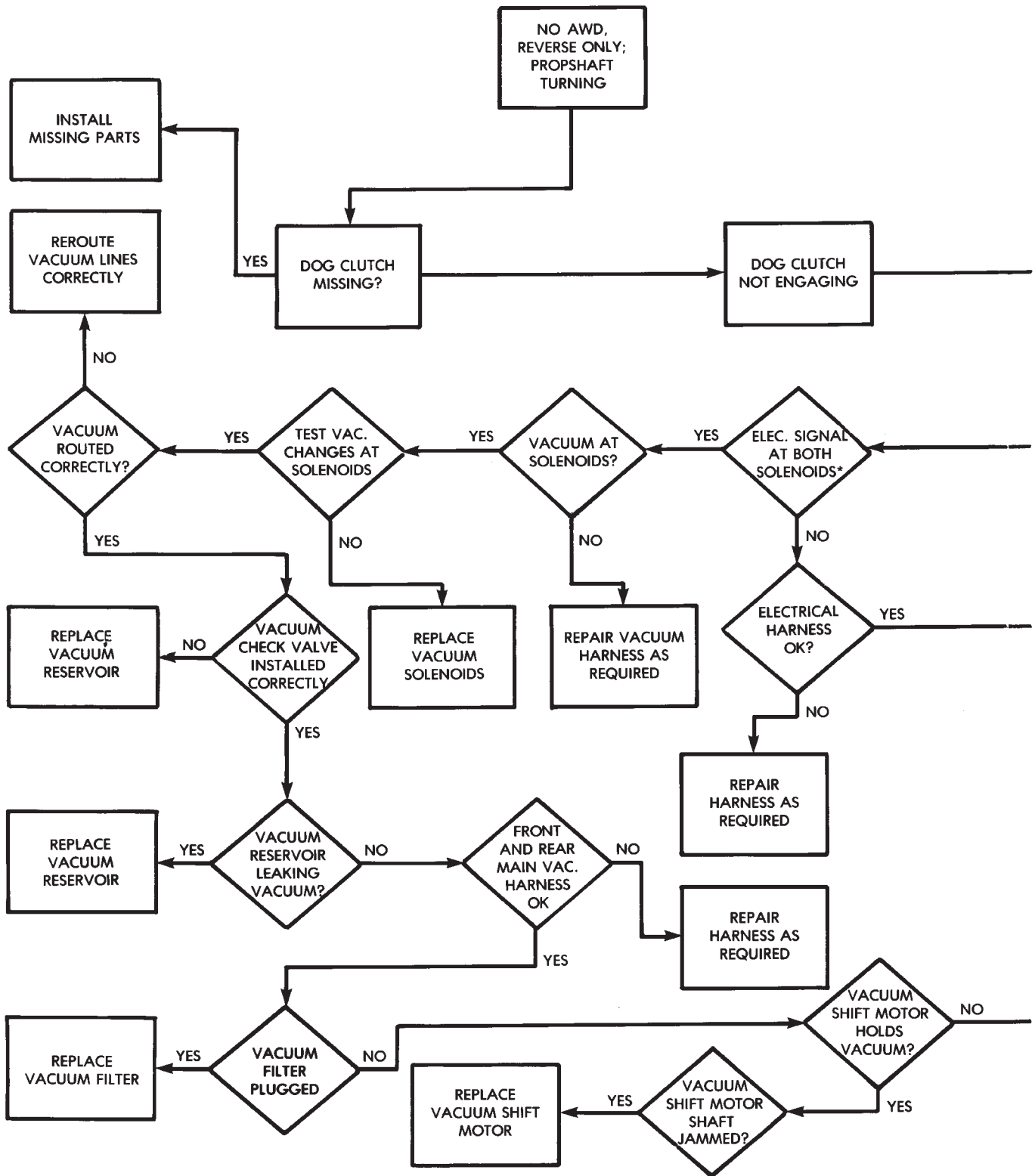

*VEHICLES IN REVERSE

NO ALL WHEEL DRIVE, REVERSE ONLY; PROPELLER SHAFT TURNING (CONT.)

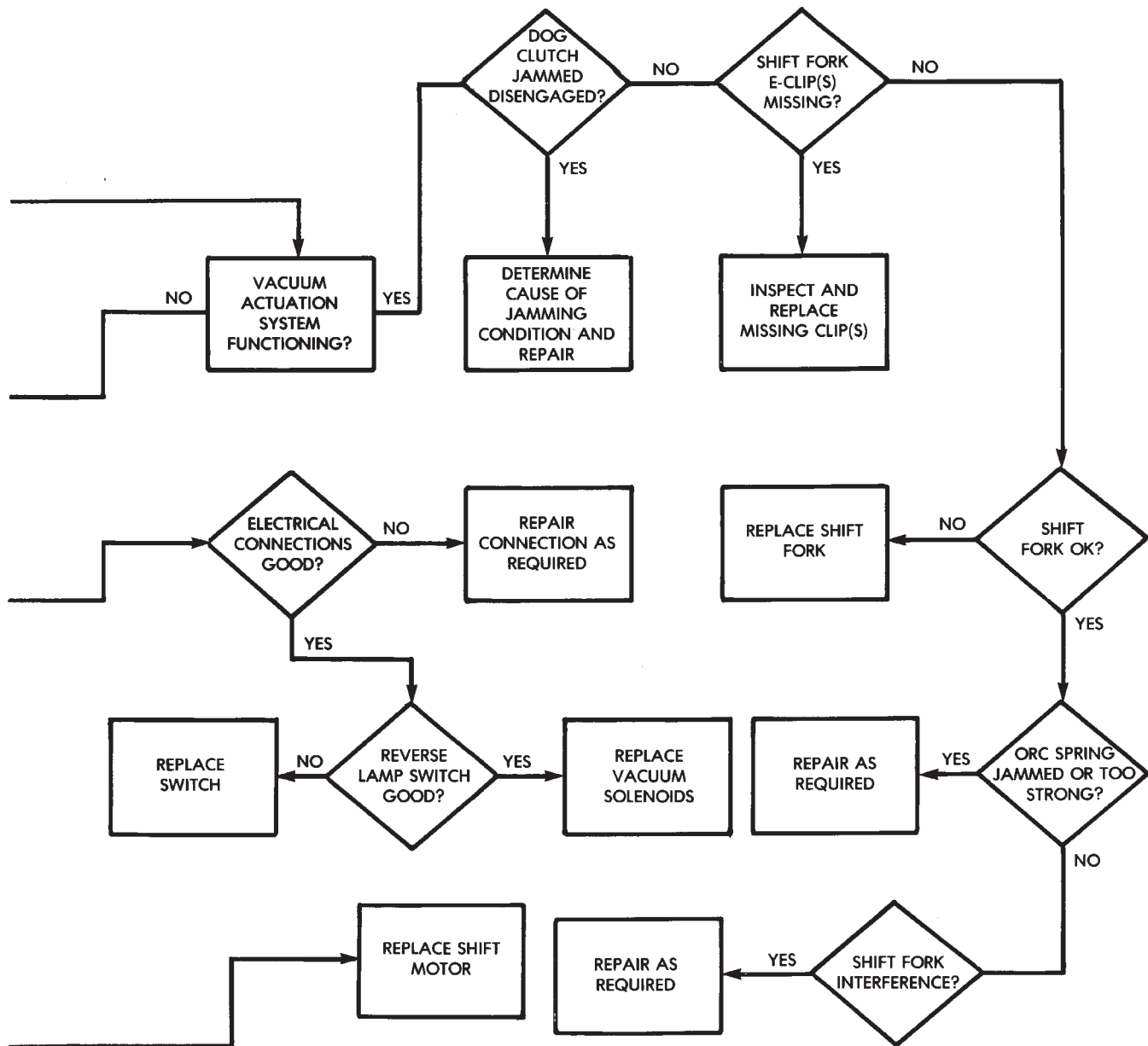



NO ALL WHEEL DRIVE, IN FORWARD; PROPELLER SHAFT TURNING

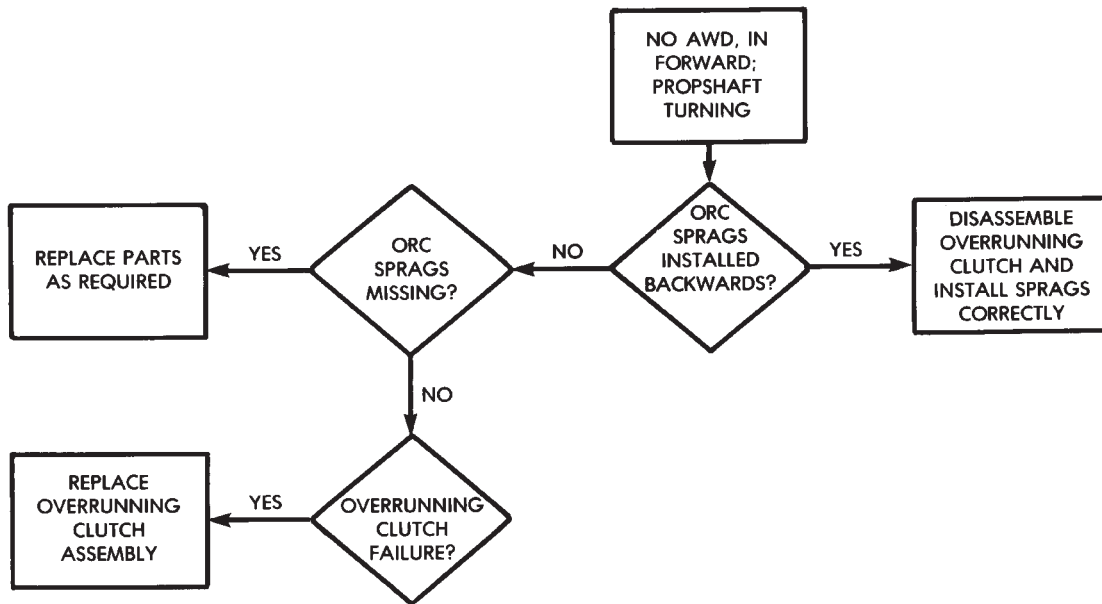

9121-270

NO ALL WHEEL DRIVE FORWARD OR REVERSE

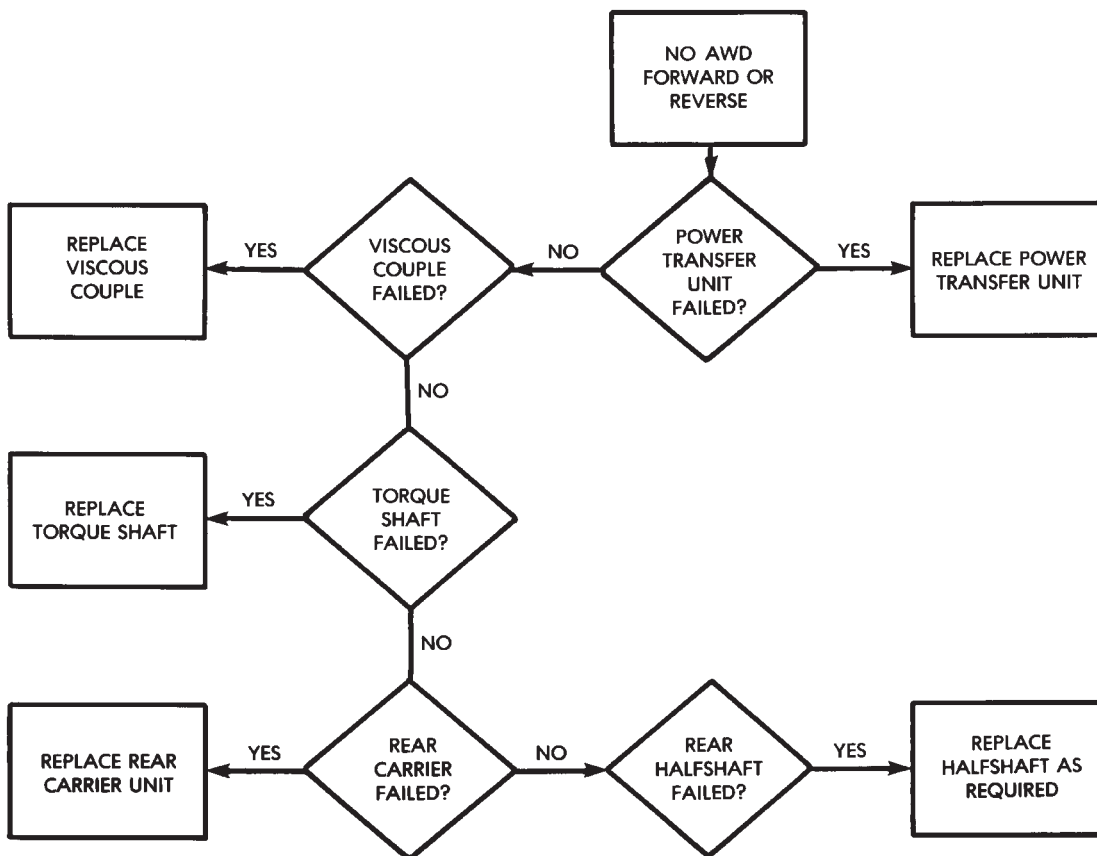

9121-271

VACUUM ACTUATION SCHEMATIC (SOLENOIDS ENERGIZED)

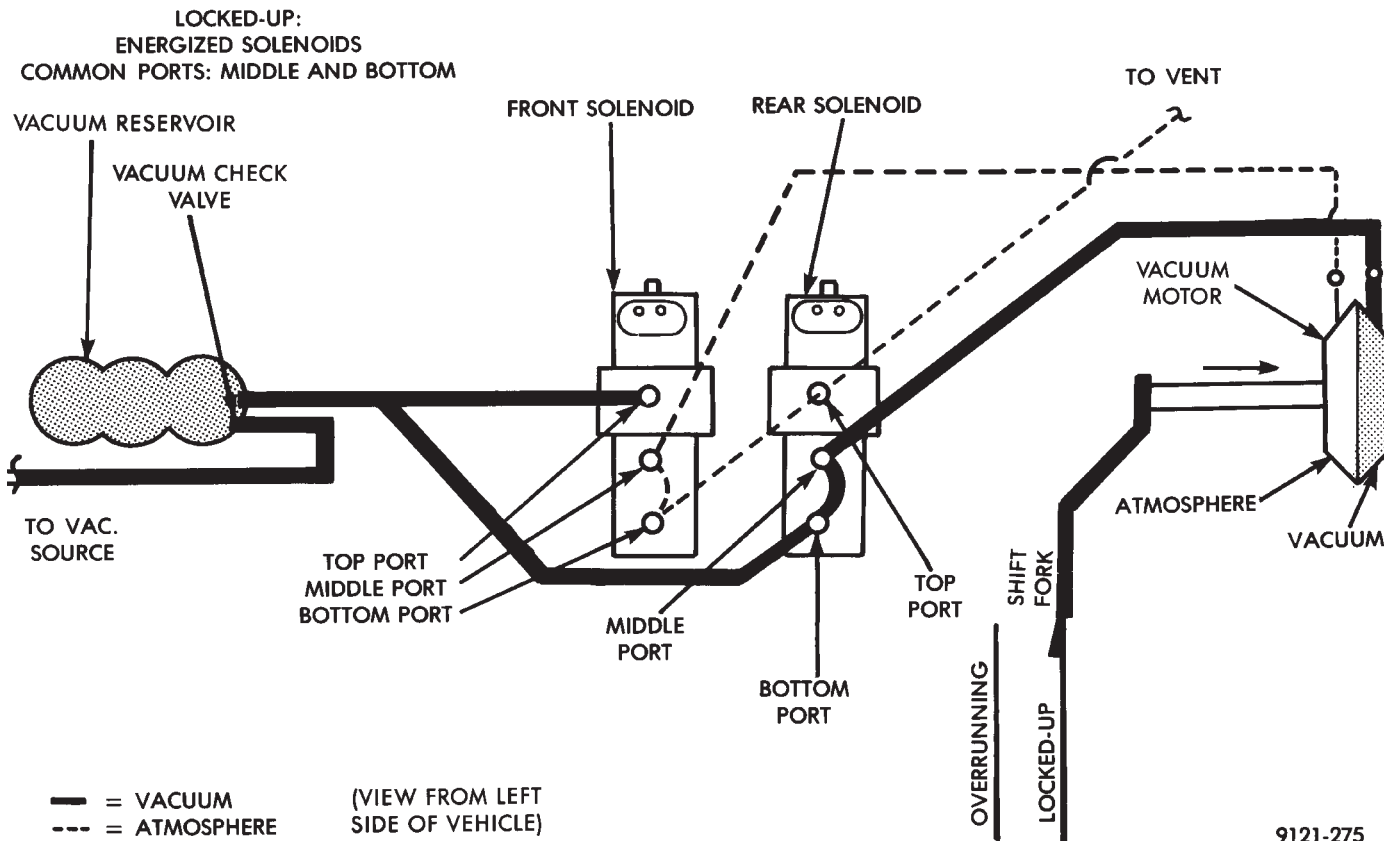

VACUUM ACTUATION SCHEMATIC (SOLENOIDS DE-ENERGIZED)

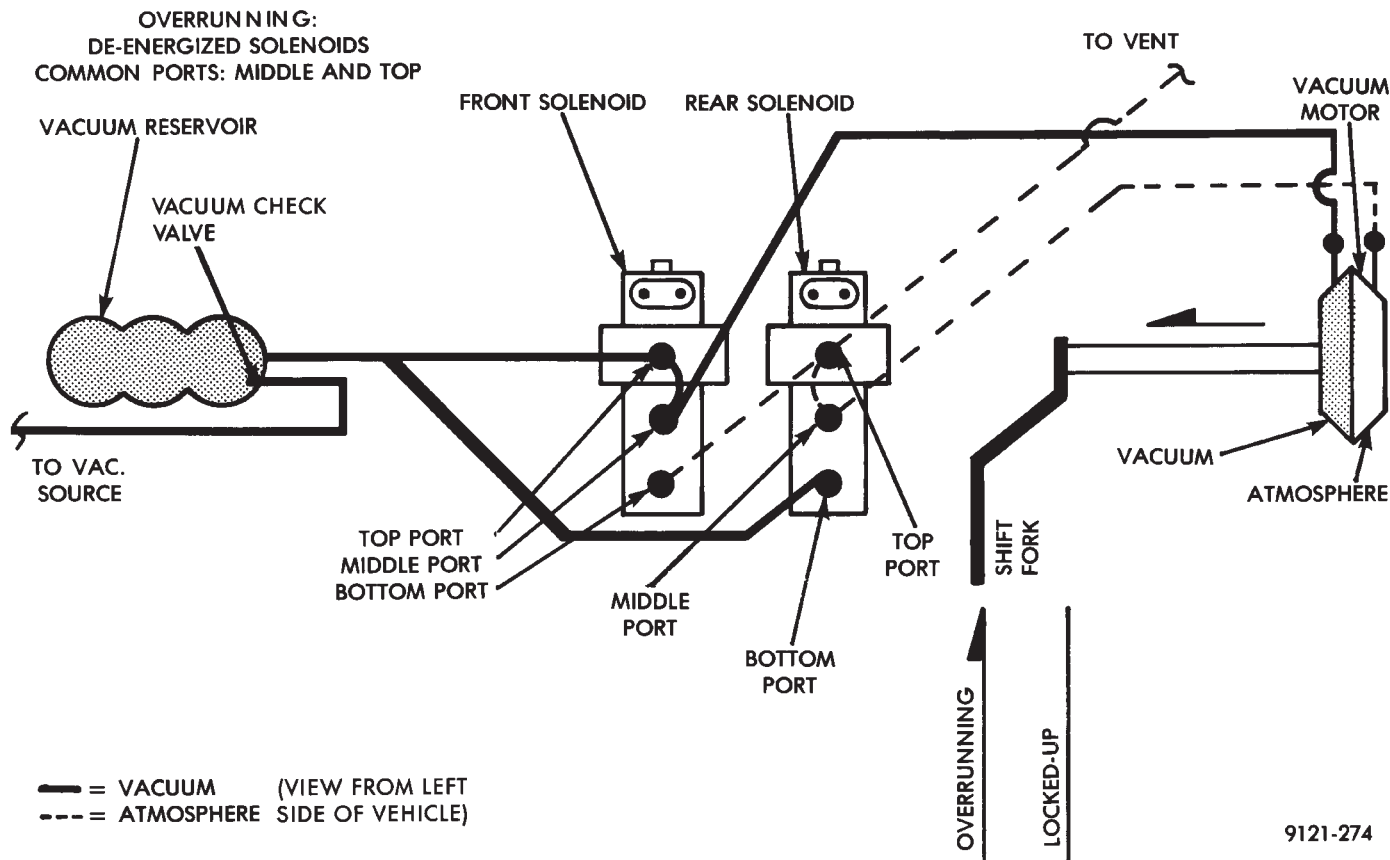

SPECIFICATIONS
TORQUE SPECIFICATIONS

DESCRIPTION	TORQUE
Assy. Nut Torque Tube	
Overrunning Clutch Case	28 N·m
Brake Assembly and Spindle	
Mounting Bolts (Rear)	108 N·m
Bushing to Axle Bracket Bolt	61 N·m
Carrier Isolator Bushing/Underbody	54 N·m
Drive Pinion Nut	380 N·m
End Cover	28 N·m
Fill Plug	27 N·m
Front Cover	12 N·m
Front Propshaft PTU and VCU	28 N·m
Hanger to Rail Frame Rail	
Bracket to Rail	33 N·m
Front and Rear Sway Bar	61 N·m
Inspection Plug	20 N·m
Jounce Bumper to Rail	33 N·m
Leaf Spring to Hanger	
Mounting Nut	142 N·m
Link Arm to Frame Rail Bracket	61 N·m
Overrunning Clutch	
Assembly to Carrier	28 N·m
Overrunning Clutch Cover Assembly	28 N·m
PTU/ATX Bracket	28 N·m

DESCRIPTION	TORQUE
PTU/Engine Bracket	40 N·m
PTU/Engine Bracket Rear	25 N·m
Rear Hub Unit/Leaf	
Spring Carrier	128 N·m
Ring Gear	95 N·m
Rear Halfshaft/Carrier	
Output Shaft	61 N·m
Shackle Bolts (All Wheel Drive)	61 N·m
Shackle Nuts	47 N·m
Shock Absorber Mounting Bolts	
Upper	115 N·m
Lower	108 N·m
Solenoid Assembly to Bracket	7 N·m
Strut Damper To Knuckle Leg	*100 N·m
Sway Bar to Link Arm	61 N·m
Torque Tube Isolator	
Bracket/Underbody	54 N·m
U-Bolts	88 N·m
Vacuum Harness Clip to Bracket	12 N·m
Vacuum Reservoir to Bracket	7 N·m
Viscous Clutch	244 N·m
*Plus 1/4 (90 Degree) Turn	

THREAD SIZE CHART

DESCRIPTION	THREAD SIZE
Assy. Nut Torque Tube Overrunning Clutch Case	M8 x 1.25
Carrier Isolator Bushing/Underbody	M10 x 1.5 x 125
Drive Pinion Nut	M30 x 1.5
End Cover	M8 x 1.25
Fill Plug	1/2 x 20
Front Cover	M6 x 1.00
Front Propshaft PTU and VCU	M8 x 1.25 x 25
Inspection Plug	M50 x 1.5
Overrunning Clutch Assembly to Carrier	M8 x 1.25
Overrunning Clutch Cover Assembly	M8 x 1.25
PTU/ATX Bracket	M8 x 1.25 x 30
PTU/Engine Bracket	M10 x 1.5 x 50
PTU/Engine Bracket Rear	M8 x 1.25 x 70
Ring Gear	M10 x 1.0
Rear Halfshaft/Carrier Output Shaft	M10 x 1.5 x 25
Rear Halfshaft/Carrier Output Shaft	M10 x 1.5 x 25
Rear Hub Unit/Leaf Spring Carrier	M12 x 1.5
Solenoid Assembly to Bracket	M6 x 1.0
Torque Tube Isolator Bracket/Underbody	M10 x 1.5 x 35
Vacuum Harness Clip to Bracket	M6 x 1.0
Vacuum Reservoir to Bracket	1/4 x 14
Viscous Clutch	M16 x 1.5

