

COOLING SYSTEM

CONTENTS

	page		page
ACCESSORY DRIVE BELTS	22	SERVICE PROCEDURES	10
ENGINE BLOCK HEATER	25	SPECIFICATIONS	27
GENERAL INFORMATION	1		

GENERAL INFORMATION

COOLING SYSTEM

Throughout this group, references may be made to a particular vehicle by letter or number designation. A chart showing the breakdown of these designations is included in the Introduction Section at the front of this service manual.

The cooling system has a radiator, coolant, electric fan motor, shroud, pressure cap, thermostat, coolant reserve system, transmission oil cooler, a water pump to circulate the coolant, hoses, and clamps to complete the circuit.

- When Engine is cold: Thermostat is closed, cooling system has no flow through the radiator. The coolant bypass flows through the engine only.
- When Engine is warm: Thermostat is open, cooling system has bypass flow and coolant flow through radiator.

Its primary purpose is to maintain engine temperature in a range that will provide satisfactory engine performance and emission levels under all expected driving conditions. It also provides hot water (coolant) for heater performance and cooling for automatic transmission oil. It does this by transferring heat from engine metal to coolant, moving this heated coolant to the radiator, and then transferring this heat to the ambient air.

Coolant flow circuits for 2.5L engine equipped vehicles is shown in Figure 1. Figure 2 shows 3.0L engine coolant routing. Figure 4 shows 3.3L Engine Coolant routing.

Excluding heated intake manifold hose routing (hose is routed from waterbox directly to heater), all other system functions are essentially the same as shown for standard engines.

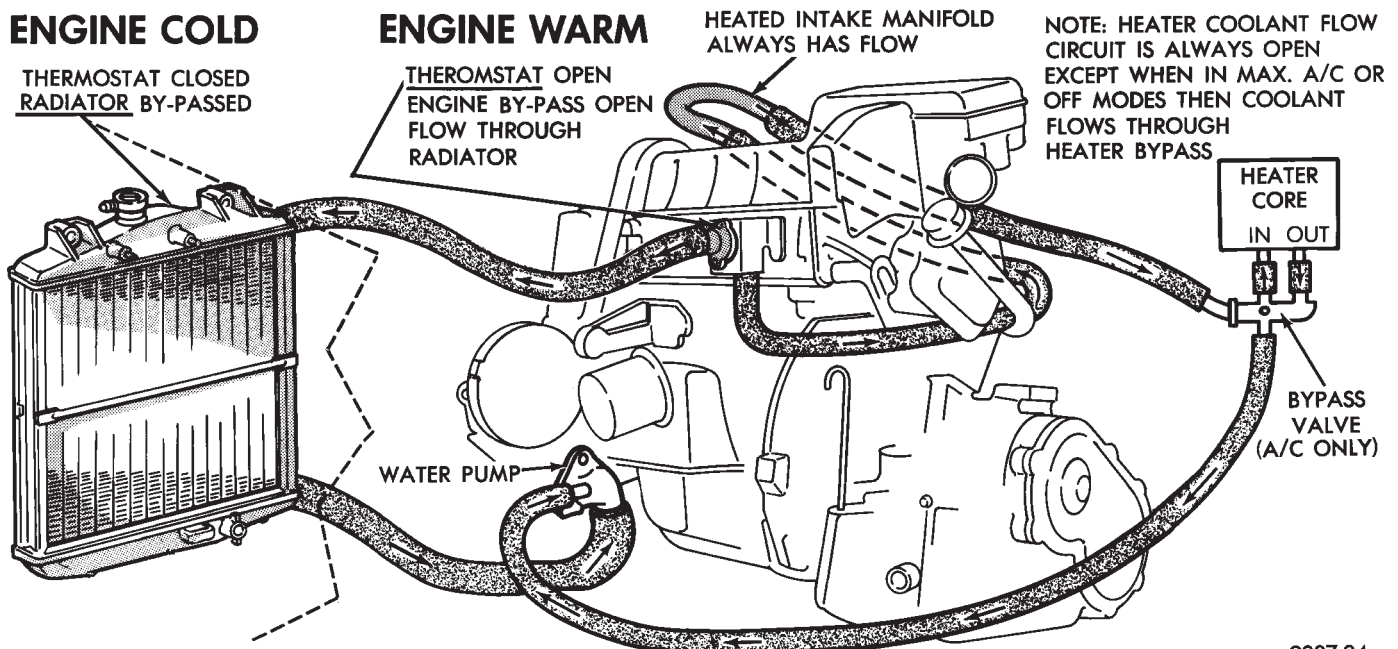

9007-24

Fig. 1 Cooling System Operation 2.5L Engines

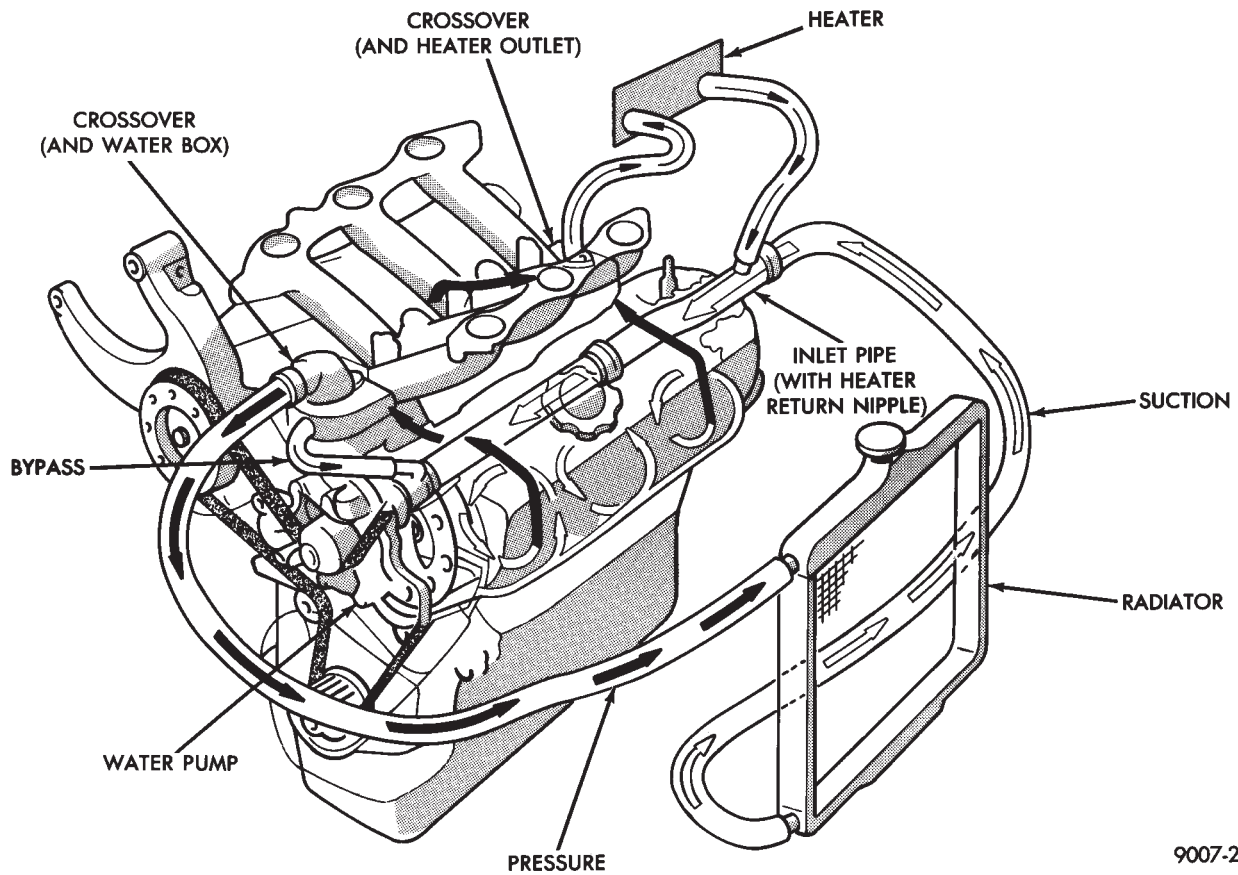

9007-25

Fig. 2 Cooling System Operation 3.0 Engine

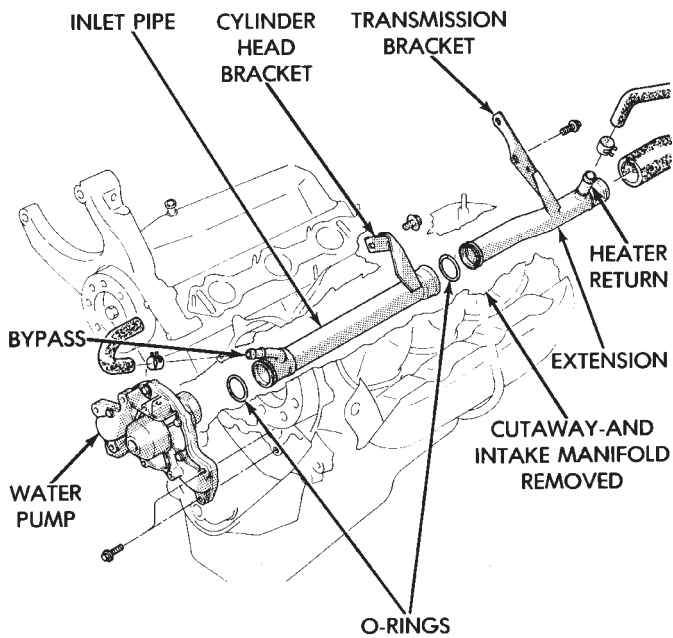

9007-1

Fig. 3 Engine Inlet Coolant Pipes

3.0L WATER PIPES

The 3.0L engines use metal piping beyond the lower radiator hose to route (suction) coolant to the water pump, which is in the V of the cylinder banks. (Fig. 3)

These pipes are provided with inlet nipples for thermostat bypass and heater return coolant hoses, and brackets for rigid engine attachment. The pipes employ O-rings for sealing at their interconnection and to the water pump (Fig. 3).

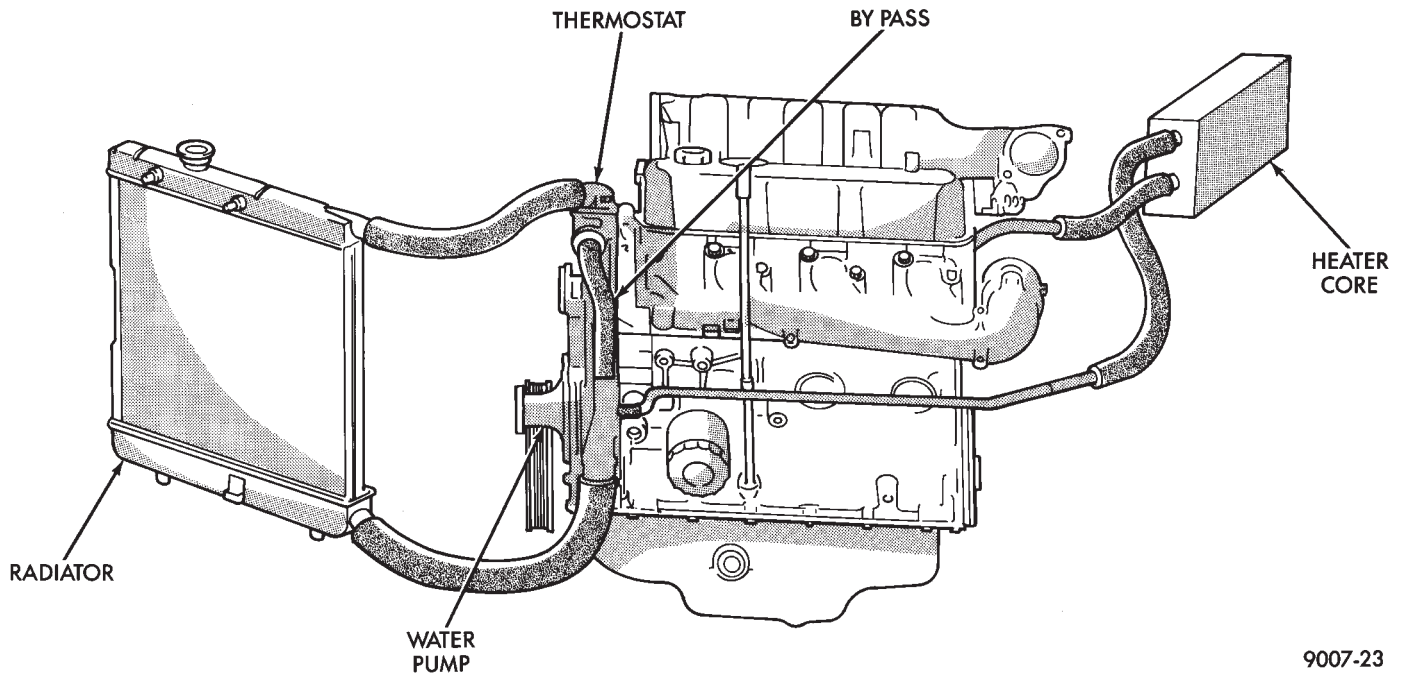

Fig. 4 Cooling System Operation 3.3L Engine

9007-23

COOLING SYSTEM DIAGNOSIS

Establish what "driving" conditions caused this complaint. Abnormal loads on the cooling system, such as the following may be the problem:

1. Prolonged Idle, Very High Ambient Temperature, Slight Tail Wind at Idle, Slow Traffic, Traffic Jams, High Speed, Steep Grades:

Driving techniques that avoid overheating are;

(a) Idle with A/C off when temperature gauge is at end of normal range.

(b) Do not increase engine speed for more air flow and coolant flow because the electric motor fan systems are not responsive to engine RPM. The added cooling from higher coolant flow rate is more than offset by increased heat rejection (engine heat added to coolant).

2. Trailer Towing:

Consult owner's manual—Trailer Towing. Do not exceed limits.

3. Air Conditioning: Add-on or After Market:

If add-on or after market A/C is involved maximum cooling components should be installed for the model involved per manufacturer's specifications.

Further diagnostic checks should not be required.

4. Recent Service or Accident Repair:

Determine if any recent service has been performed on the vehicle that may affect the cooling system such as engine adjustment (wrong timing), loose or slipping water pump belt, brakes (possibly dragging), changed parts (possibly wrong), recored radiator or cooling system refilling (possibly under-filled or trapped air).

If investigation reveals none of the above as cause for overheating complaint refer to the following symptoms chart.

Symptom	Action
Blinking Engine Warning Light Or High Gauge Indication—Without Coolant Loss	Normal with temporary operation with heavy load, towing a light trailer, high outdoor temperatures, and/or on a steep grade.
Coolant Loss	Improper refilling procedures can result in trapped air in the system. Subsequent operation of the pressure cap and coolant recovery system will deaerate the cooling system. A low coolant level will result in the Coolant Reserve Tank. Add coolant. If condition persists see System Diagnosis.
Fan Never Runs	Consult Electrical, Group 8.
Fan Always Runs	Normal with A/C compressor clutch engaged. Otherwise consult Electrical Group 8.
Hot Car (Not Engine) Heat Damage Hot Carpet, Seat, Trunk Hot Catalytic Converter Smoke, Burnt Odor	Check heat shielding, exhaust system, emission controls, ignition timing—fuel/air ratio, misfiring.
Hot Engine Crackling Sounds Hot Smell Severe Local Hot Spots	A moderate amount of sound of heating metal can be expected with any vehicle. However, a crackling sound from the thermostat housing, a hot smell and/or severe local hot spots on an engine can indicate blocked coolant passages. Inspect for plugged water passages, bad casting, core sand and plugging, a cracked block or head, or a blown head gasket. Usually accompanied with coolant loss.
Coolant Color	Coolant color is not necessarily an indication of adequate temperature or corrosion protection.
Coolant Recovery Bottle —Level Changes	Level changes are to be expected as coolant volume changes with engine temperature. If the level in the bottle is between the Maximum and Minimum marks at normal engine operating temperature, the level should return to within that range after operation at elevated temperatures.
—Coolant NOT Returning	Coolant will not return to the radiator if the radiator cap vent valve does not function, if an air leak destroys vacuum, or if the overflow passage is blocked or restricted. Inspect all portions of the overflow passage, pressure cap, filler neck nipple, hose, and passageways within the bottle for vacuum leak only. Coolant return failure will be evident by a low level in the radiator. Bottle level should increase during heat-up.

COOLING SYSTEM DIAGNOSIS

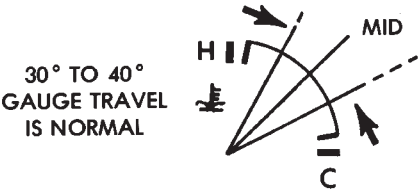
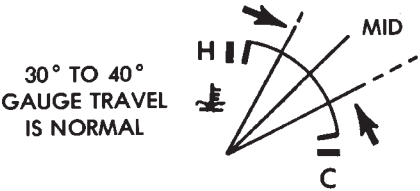
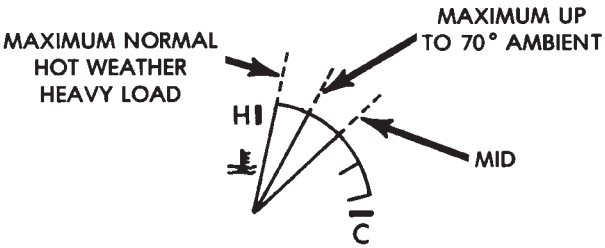
CONDITION—AND CHECKS	DIAGNOSIS
<p>MAGNETIC 90° GAUGE READS LOW</p>  <p>30° TO 40° GAUGE TRAVEL IS NORMAL</p> <ol style="list-style-type: none"> Verify gauge, (Fig. 1) Is temperature really low? Is code 17 set in diagnostics? Does it read cold? Coolant level low in cold ambient. (Also poor heater performance) Coolant level O.K. 	 <p>Fig. 1—Normal Gauge Travel</p> <ol style="list-style-type: none"> See Electrical, Group 8 and check temperature sending unit. Repair/Replace gauge. Yes—Thermostat, No—Other Wiring disconnect wrong sending unit used, sending unit for HOT life, not gauge. Check radiator and CRS for level—inspect for leaks. Check heater controls, doors—see Group 24, Heaters and Air Conditioning.
<p>GAUGE READS HIGH—Without Pressure Cap Blow off without Coolant or Steam from CRS Tank and to Ground</p> <ol style="list-style-type: none"> Is it really reading high? If at "H" without other signs of boiling. Coolant level low in Radiator and CRS Coolant level low in Radiator but not in CRS. 	 <p>MAXIMUM NORMAL HOT WEATHER HEAVY LOAD</p> <p>MAXIMUM UP TO 70° AMBIENT</p> <p>MID</p> <p>Fig. 2—Gauge Reading—Hot Weather—Heavy Load</p> <ol style="list-style-type: none"> See Figure 2. Look for Grounded gauge, sending unit or wire. See Group 8, Electrical. a—Fill full remembering to vent air (2.5L Engine). b—Inspect for leaks, repair. c—Assure Pressure Cap was shut tight and seals at top and bottom of neck are functioning properly. a—Fill full remembering to vent air (2.5L Engine). b—Inspect for leaks and repair. c—Inspect for leaks in CRS to radiator connection. d—Assure cap seals at top and bottom.

COOLING SYSTEM DIAGNOSIS

CONDITION—AND CHECKS	DIAGNOSIS
(5) Check freeze point.	(5) a—Adjust to 50/50 Glycol and water. b—If no reading or below -59°C (-50°F), mixture is too rich clean system before refilling
(6) Assure Coolant Flow.	(6) a—Look for flow through filler neck with some coolant removed and thermostat open (6) b—Repair water pump if necessary. See Water Pump Section.
(7) Other possible causes.	(7) a— High speed only —Radiator or Condenser air side plugged —Radiator core tubes plugged —Add on A/C without proper radiator —Engine out of tune (specifications) —Brakes dragging —Bug screen —Trailer towing or hill climbing b— High and Low Speed —Thermostat failed partially shut particularly if ambient temperature is below 21°C (70°F) and vehicle has high mileage. —Condenser or radiator air side plugged. —Add on A/C. c— Low Speed—NOT high speed —Fan not operating. —Check Diagnostics. —Check Fan Motor by wiring to battery, when disconnected from harness. —Check, Group 8, Electrical.
Temperature Gauge Reads Hot with Pressure Cap Blowoff and Steam and coolant to CRS and to Ground	
(1) Coolant Level Low in Radiator and CRS	(1) a—Fill Cooling System Full and Vent Air. b—Inspect for Leaks—repair. c—Assure Pressure cap was shut and seals. d—If low in radiator but not in CRS, also check connection to filler neck and pressure cap sealing.
(2) Check Coolant Freeze point.	(2) Adjust to 50/50 Glycol and water. -37°C (-35°F .)
(3) Assure Coolant Flow.	(3) a—Look for flow through radiator filler neck with coolant lowered and thermostat open. b—When accompanied with "metal cracking sound"—consider core sand and/or bad head casting.
(4) Thermostat failed shut.	(4) Especially in cold to medium ambient temperatures.
(5) Head Gasket Leak.	(5) Use block leak checker.

COOLING SYSTEM DIAGNOSIS

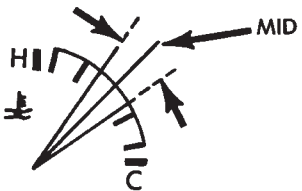
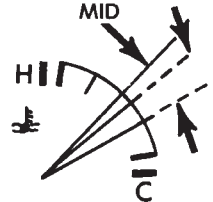
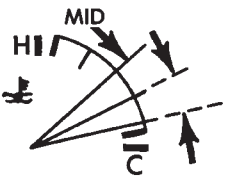
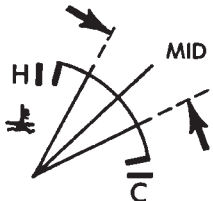
CONDITION—AND CHECKS	DIAGNOSIS
<p>Temperature Gauge Is Inconsistent Cycles—Erratic</p> <p>(1) Is cycle normal?</p>	 <p>Fig. 3—Normal Reaction to Fan Cycle</p> <p>(1) a—Normal Fan Cycle Due to Temperature. Raises Slowly—Drops Fast (Fig. 3)</p>  <p>Fig. 4—Gauge Reaction to Thermostat</p> <p>b—Normal Thermostat Cycle (Fig. 4)</p>  <p>Fig. 5—Gauge Reaction—Winter, Idle, Heater On</p> <p>c—Normal cycle at idle in winter with Heater on high. (Heater Heat Transfer exceeds engine Heat Rejection) drops lower with time. Sometimes noticed in winter between Drive and Idle (Fig. 5)</p>  <p>Fig. 6—Gauge Reaction—Stop after Heavy Use</p> <p>d—Hot water normal build up at stop after heavy use (Fig. 6)</p>
<p>(2) Is coolant level low in radiator (Low level can trap air in system which can put thermostat pellet in air and it opens late).</p>	<p>(2) Fill system, vent air (2.5L engine) and inspect for leaks.</p>

COOLING SYSTEM DIAGNOSIS

CONDITION - AND CHECKS	DIAGNOSIS
(3) Is there a head gasket leak that puts exhaust gas in system? (This acts like trapped air with same effect as 2 above.)	(3) a - Test with block leak checker and replace if necessary. b - Coolant in engine oil. c - White steam coming out of exhaust.
(4) Water pump impeller loose on shaft, slips sometimes.	(4) Replace.
(5) Air lead on suction side of water pump entraining air; see 2 above.	(5) Find leak and repair.
Warning Light Glows All the Time (No Gauge)	
(1) Check temperature sending unit. The sending unit for a light is a switch and has a screwdriver slot in the electrode that is used for calibration. The gauge sending units do NOT have a screwdriver slot.	(1) It is probably a sending unit for a gauge, NOT for a light.
Pressure Cap Blow-Off, With Steam to CRS and Coolant to Ground Without High Reading. Temperature Gauge Above Normal.	
(1) Check pressure cap relief pressure.	(1) Replace if lower than 14 psi.
Coolant Loss to Ground Without Pressure Cap Blow-Off	
(1) Leaks.	(1) a - Pressure test system while shaking hoses. b - Water pump seal. See "water pump," this Group.
Coolant Loss Past Pressure Cap Top Seal - Glycol Seen on Filler Neck	
(1) With normal gauge reading.	(1) a - Cap not on tight. b - Top seal leaking. c - Cap diaphragm "oil canned." d - Filler neck damaged. e - Rubber seal out of position.
(2) With high gauge reading or low gauge reading on new vehicle.	(2) a - CRS hose kinked. b - CRS tank and plastic tube plugged. c - Pressure cap rubber seal out of position.
Detonation or Pre-Ignition When Nothing to Cause It in Engine or Ignition	
(1) Check freeze point of coolant. If tester does not register reading or the reading is below -59°C, be aware that 100% glycol makes engine metal run hotter even without a hot gauge reading.	(1) a - Adjust coolant to 50/50 glycol and water -37°C. b - If 100% glycol has been found in the system, clean and flush the system before replacing with 50/50 glycol and water.
Hoses Observed Collapsing on Cool-Down	
(1) Check pressure cap vent valve.	(1) a - Must be free to move. Gasket swell can prevent valve from opening. b - Replace cap.
(2) Check CRS hose for kinking or plugging.	(2) Repair as required.
(3) Inside of cap plugged with stop leak pellet, green silica gel, or fiberglass.	(3) Clean cap.
Fan Runs All the Time	
(1) Check for relay.	(1) See Group 8, Electrical.
Fan Noisy	
(1) Check for loose fan.	(1) Repair as necessary.
(2) Check for fan clearance to adjacent parts.	
(3) Check for loose mount fasteners.	
(4) Check for bent fan blades.	
(5) Check for fan blades spinning on hub.	
(6) Check for air obstructions on radiator or condenser.	

COOLING SYSTEM DIAGNOSIS

CONDITION - AND CHECKS	DIAGNOSIS
Inadequate Air Conditioning Performance – Cooling Systems Suspected	
(1) Check for plugged air side of condenser and radiator – front and rear.	(1) Wash out with low-velocity water.
(2) Assure fan runs whenever A/C compressor clutch is engaged.	(2) Repair as necessary.
(3) Check for missing air seals-recirculating air path.	
(4) Assure correct cooling system parts.	
Battery Dead – Suspect Fan Current Draw as Cause	
(1) With a good, fully charged battery.	(1) a – Assure fan control is operating properly. b – See Charging System in Electrical, Group B.
Hot Smell – Suspect Cooling System	
(1) Was temperature gauge high?	(1) a – Yes, See "Gauge Reads High." b – No, See 2, 3, 4, and 5.
(2) Heat shields all in place?	(2) a – Yes, See 3, 4, and 5. b – Repair as required.
(3) Fan control operating properly?	(3) a – Yes, See 4 and 5. b – No, See "Fan," this Group.
(4) Heat exchanger air side plugged?	(4) Clean as required.
(5) Engine missing or running rich?	(5) Repair as required.
Poor Driveability – Suspect Failed Open Thermostat	
(1) Check diagnostics – is code 17 set?	(1) If yes, change thermostat.
Poor Heater Performance – Suspect Failed Open Thermostat	
(1) Does gauge read low?	(1) See 3a.
(2) Check coolant level.	(2) See 3a.
(3) Check diagnostics – is code 17 set?	(3) If yes, change thermostat. If no, check heater bypass valve, which should be closed except in Max A/C or Off mode; if not, see Heater and Air Conditioning, Group 24.
Steaming, Observe Water Vapor Through Grill or Head Gap at Standstill at Idle – In Wet Weather	
(1) This is normal. It is moisture, snow, or water on the outside of the radiator that evaporates when the thermostat opens to put hot water into the radiator. This usually occurs in cold weather with no fan or air flow to blow it away.	(1) Normal condition – no service required.

SERVICE PROCEDURES

WATER PUMPS

A quick test to tell whether the pump is working is to see if the heater warms properly. A defective pump can not circulate heated coolant through the long heater hose.

The water pump on all models can be replaced without discharging the air conditioning system.

WATER PUMP 2.5L ENGINE

The 2.5L engine water pump has a diecast aluminum body and housing with a stamped steel impeller. The 2.5L pump uses an O-ring gasket between body and housing. The assembly bolts directly to the block. Cylinder block to water pump sealing uses a rubber O-ring.

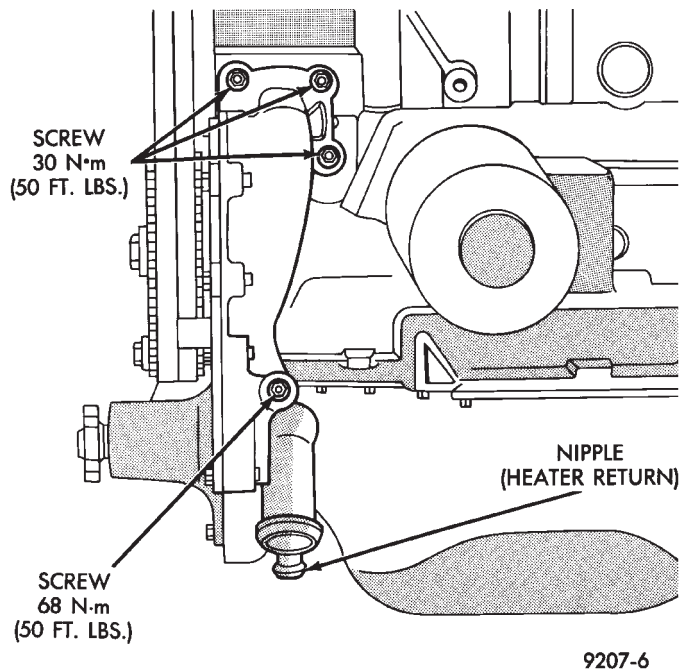

Fig. 1 Water Pump 2.5L Engines

REMOVAL

(1) Drain cooling system. Refer to Draining Cooling System in this group.

(2) If equipped with air conditioning, see Solid Mount Accessory Bracket in (Standard Service Procedures) Group 9, Engine:

(a) Remove air conditioning compressor and generator from solid mount bracket and set aside. It is not necessary to discharge the a/c system.

(b) Remove solid mount bracket.

(3) If the vehicle is not equipped with air conditioning, remove generator and mounting bracket.

(4) Disconnect lower radiator and heater hoses from pump.

(5) Remove water pump attaching screws to engine (Fig. 1).

DISASSEMBLY

(1) Remove three screws holding pulley to water pump.

(2) Remove nine screws holding water pump body to housing. Remove the pump body from housing. (Fig. 2)

(3) Clean gasket surfaces on water pump housing and engine block.

(4) Remove and discard O-ring gaskets and clean O-ring grooves.

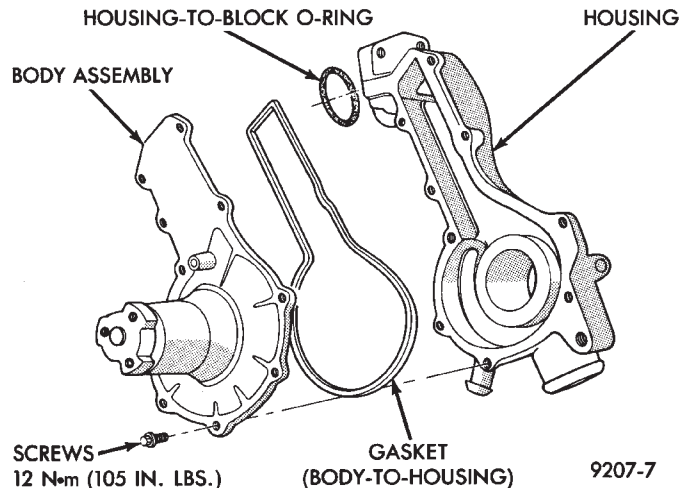

Fig. 2 Water Pump Components—2.5L Engines

INSPECTION

Replace water pump body assembly if it has any of these defects:

(1) Cracks or damage on the body.

(2) Water leaks from the shaft seal, evident by coolant traces below the vent hole.

(3) Loose or rough turning bearing.

(4) Impeller rubs either the pump body or the housing.

ASSEMBLY

Body assembly and housing are serviced as separate components.

(1) Install new O-ring gasket in body O-ring groove.

(2) Assemble pump body to housing and tighten nine screws to 12 N·m (105 in. lbs.) (Fig. 2).

(3) Rotate pump by hand to check for freedom of movement.

(4) Position water pump pulley to water pump. Install three screws and tighten to 30 N·m (250 in. lbs.).

(5) Position new O-ring in housing to block O-ring groove.

INSTALLATION

- (1) Install water pump on engine. Tighten top three screws (Fig. 1) to 30 N•m (250 in. lbs.). Install lower screw and tighten to 68 N•m (50 ft. lbs.).
- (2) Reinstall bypass/heater hose and lower radiator hose.
- (3) Reinstall generator and air conditioning compressor bracket(s). For solid mount bracket see standard service procedures in Group 9 Engine.
- (4) Reinstall generator and air conditioning compressor.
- (5) Refill cooling system. See **Refilling Cooling System**.
- (6) Install drive belt, See Accessory Drive Belts, this Group.

WATER PUMP 3.0L ENGINE

The 3.0L pump bolts directly to the engine block, using a gasket for pump to block sealing (Fig. 3). The pump is serviced as a unit.

The water pump is driven by the timing belt. See Timing System in Group 9, Engine for component removal providing access to water pump.

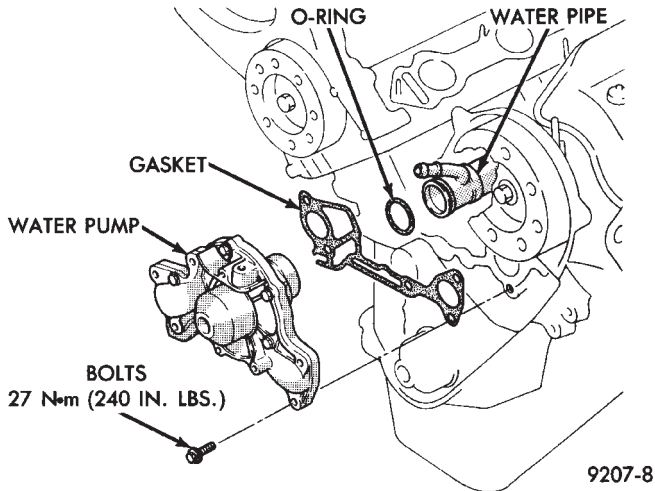

Fig. 3 Water Pump 3.0L Engine

REMOVAL

- (1) Drain cooling system. Refer to Draining Cooling System in this group.
- (2) Remove mounting bolts.
- (3) Separate pump from water inlet pipe (Figs. 3 and 4) and remove.

INSPECTION

Replace the water pump if it has any of the following defects.

- (1) Damage or cracks on the pump body.
- (2) Coolant leaks, if the shaft seal is leaking, evident by traces of coolant leaks from vent hole A in (Fig. 4).
- (3) Impeller rubs the inside of pump.
- (4) Loose or rough turning bearing.

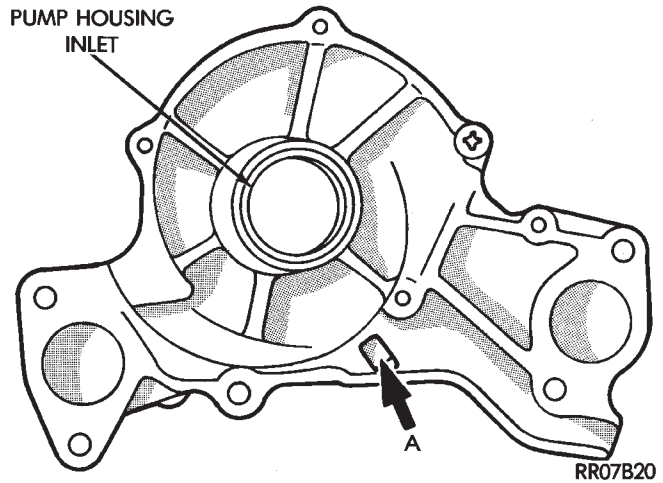

Fig. 4 Water Pump Inspection

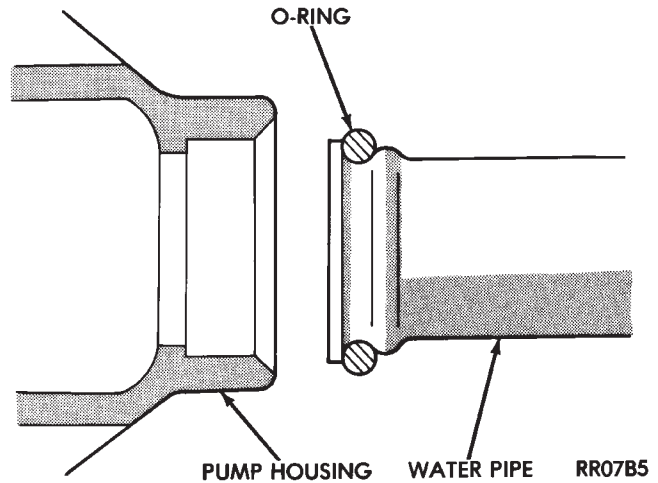

Fig. 5 Water Pipe O-Ring

INSTALLATION

- (1) Clean all gasket and O-ring surfaces on pump and water pipe inlet tube.
- (2) Install new O-ring on water inlet pipe (Fig. 5). Wet the O-ring (with water) to ease assembly.

CAUTION: Keep the O-ring free of oil or grease.

- (3) Install new gasket on water pump and install pump inlet opening over water pipe, press assembly to cause water pipe insertion into pump housing.
- (4) Install pump to block mounting bolts and tighten to 27 N•m (20 ft. lbs.).
- (5) See Timing System in Engine, Group 9 and install timing belt. Reassemble engine.
- (6) Fill cooling system. See Refilling Cooling System.

WATER PUMP 3.3L ENGINE

The 3.3L pump has a die cast aluminum body and a stamped steel impeller. It bolts directly to the chain case cover, using an O-ring for sealing. It is driven by the back surface of the Poly-V Drive Belt.

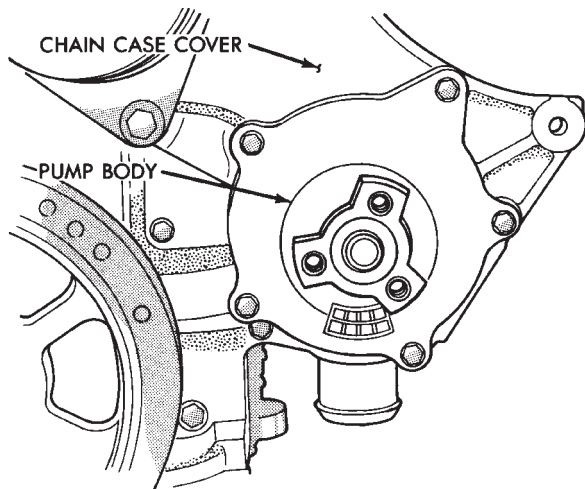

9007-6

Fig. 6 Water Pump 3.3L Engine

REMOVAL

- (1) Drain Cooling System. Refer to Draining Cooling System in this group.
- (2) Remove Poly V Drive Belt.
- (3) Remove right front lower fender shield.
- (4) Remove pump pulley bolts and remove pulley.
- (5) Remove pump mounting screws (Fig. 6). Remove pump.
- (6) Remove and discard O-ring seal.
- (7) Clean O-ring groove and O-ring surfaces on pump and chain case cover. Take care not to scratch or gouge sealing surface.

INSPECTION

Replace the water pump if it has any of the following defects.

- (1) Damage or cracks on the pump body.
- (2) Coolant leaks; if the seal is leaking, evident by traces of coolant leaks from vent hole.
- (3) Loose or rough turning bearing.
- (4) Impeller rubs either the pump body or chain case cover.

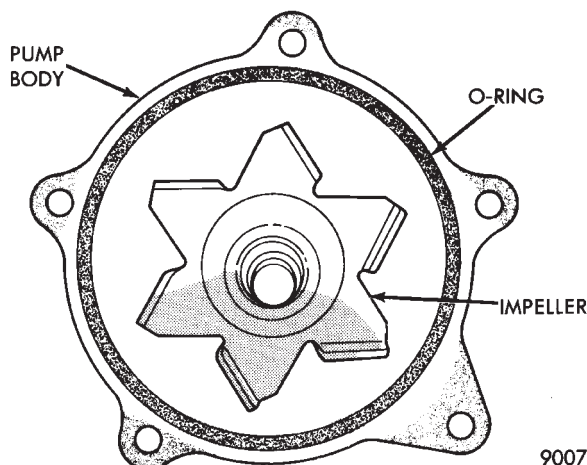

9007-7

Fig. 7 Water Pump Body

INSTALLATION

- (1) Install new O-ring in O-ring groove (Fig. 7).
- (2) Install pump to chain case cover. Torque screws to 12 N•m (105 in. lbs.)
- (3) Rotate pump by hand to check for freedom of movement.
- (4) Position pulley on pump. Install screws and torque to 30 N•m (250 in. lbs.).
- (5) Install drive belt. See Accessory Drive Belts this group.
- (6) Install right front lower fender shield.
- (7) Refill Cooling System. See Refilling Cooling System.

ENGINE THERMOSTAT

The 2.5L engine thermostat is located on the front of the engine (radiator side) in the waterbox that is part of the cylinder head construction (Fig. 8).

These thermostats do not have an air bleed notch.

The 3.0L and 3.3L engine thermostats are in water boxes, formed in the timing belt end of the intake manifold. These thermostat have air bleed valves, located in the thermostat flange (Figs. 9 and 10).

DESCRIPTION AND OPERATION

The engine cooling thermostats are wax pellet driven, reverse poppet choke type. They are designed to provide the fastest warm up possible by preventing leakage through them and to guarantee a minimum engine operating temperature of 88 to 93°C (192 to 199°F). They also automatically reach wide open so they do not restrict flow to the radiator as temperature of the coolant rises in hot weather to around 104°C (220°F). Above this temperature the coolant temperature is controlled by the radiator, fan, and ambient temperature, not the thermostat.

OPERATION AND TESTING

The thermostat operates by a wax filled container (pellet) that is sealed so that when heated to a pre-determined temperature. The wax expands enough to overcome the closing spring and water pump pressure, which forces the valve to open. Coolant leakage into the pellet will cause a thermostat to fail open. Do not attempt to free up a thermostat with a screwdriver.

The open too soon type failure mode is included in the on-board diagnosis. The check engine light will not be lit by an open too soon condition. Only if the thermostat has failed open, a code 17 will be set. Do not change a thermostat for lack of heat by gauge or heater performance, unless code 17 is present, see diagnosis for other probable causes. Failing shut is the normal long term mode of failure, and normally, only on high mileage vehicles. The temperature gauge will show this, Refer to diagnosis in this section.

REMOVAL

- (1) Drain cooling system down below the thermostat level. Refer to Draining Cooling System in this group.
- (2) Remove thermostat housing bolts and housing (Figs. 8, 9 and 10).
- (3) Remove thermostat, discard gasket and clean both gasket sealing surfaces.

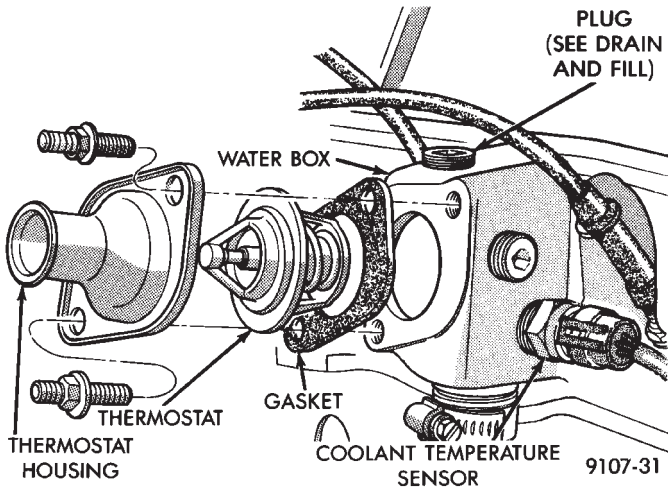

Fig. 8 Thermostat, Housing, and Water Box—2.5L Engine

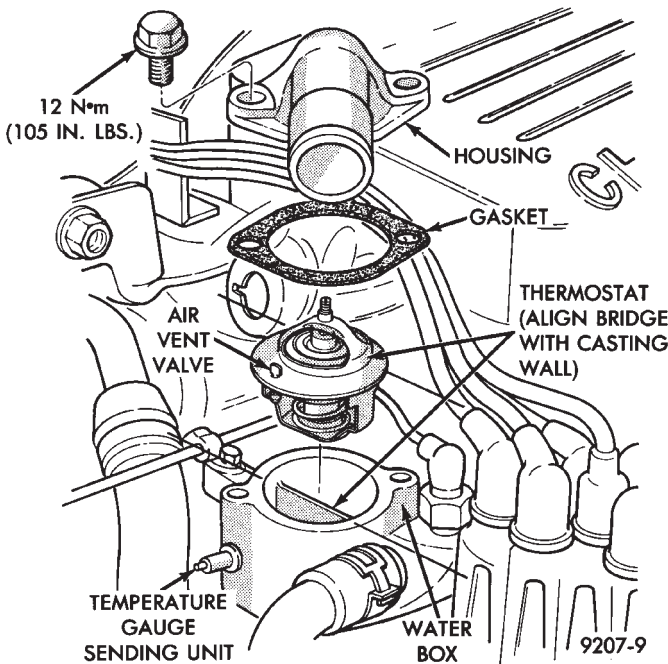

Fig. 9 Thermostat, Housing, and Water Box—3.0L Engine

INSTALLATION—2.5L ENGINE

Place a new gasket (dipped in clean water) on water box surface, center thermostat in water box on gasket. Place housing over gasket and thermostat, making sure thermostat is in the thermostat hous-

ing. Bolt housing to water box (Fig. 8). Tighten bolts to 28 Nm (250 in. lbs.). Refill cooling system (see **Refilling System**).

INSTALLATION—3.0L ENGINE

Center thermostat in water box pocket. Check that the flange is seated correctly in the countersunk portion of the intake manifold water box (Figs. 9 and 10). Install new gasket on water box. Install housing over gasket and thermostat and tighten bolts to 12 Nm (133 in. lbs.).

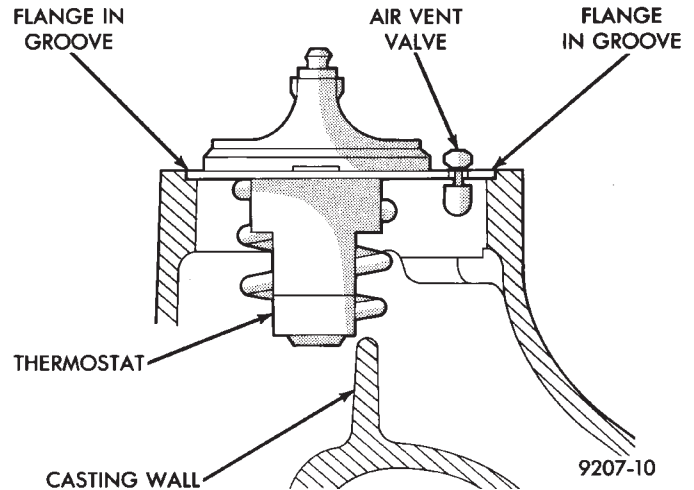

Fig. 10 Thermostat Installed—Typical

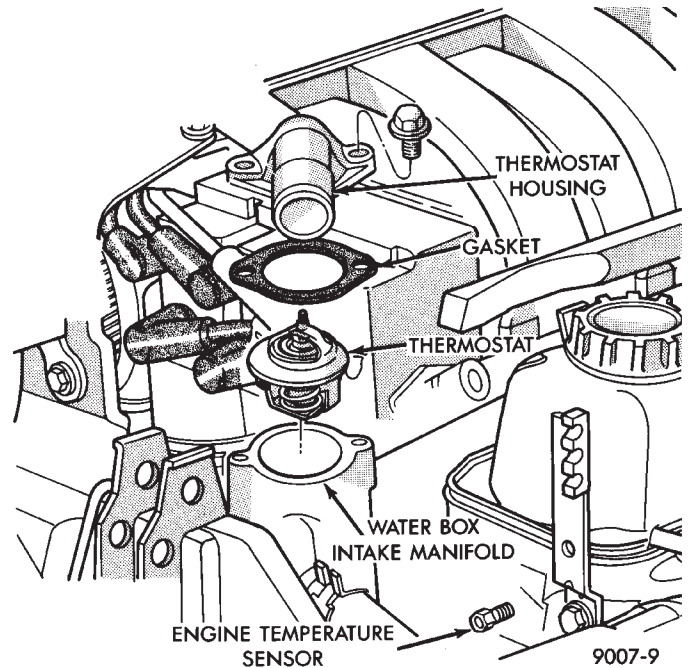

Fig. 11 Thermostat, Housing and Waterbox—3.3L Engine

INSTALLATION—3.3L

Place a new gasket (dipped in water) on the water box surface, center thermostat into opening in the intake manifold. Place housing over gasket and ther-

mostat, making sure thermostat is in recess provided (Fig. 11). Bolt housing to intake manifold, tighten bolts to 28 N•m (250 in. lbs.). Refill cooling system (see **Refilling System**).

COOLANT

The cooling system is designed around the coolant. The coolant must accept heat from engine metal, in the cylinder head area near the exhaust valves. Then carry this heat to the radiator where the tube/fin assemblies of these components can give it up to the air.

PERFORMANCE

Performance is measurable. For heat transfer pure water excels (Formula = 1 btu per minute for each degree of temperature rise for each pound of water). This formula is altered when necessary additives to control boiling, freezing, and corrosion are added as follows:

- Pure Water (1 btu) boils at 100°C (212°F) and freezes at 0°C (32°F)
- 100 percent Glycol (.7 btu) can cause a hot engine and detonation and will lower the freeze point to -22°C (-8°F).
- 50/50 Glycol and Water (.82 btu) is the recommended combination that provides a freeze point of -37°C (-35°F). The radiator, water pump, engine water jacket, radiator pressure cap, thermostat, temperature gauge, sending unit and heater are all designed for 50/50 glycol.

Where required, a 56 percent glycol and 44 percent water mixture will provide a freeze point of -59°C (-50°F).

CAUTION: Richer mixtures cannot be measured with field equipment that can lead to problems associated with 100 percent glycol.

SELECTION AND ADDITIVES

The use of aluminum cylinder heads, intake manifolds, and water pumps requires special corrosion protection. Mopar Antifreeze, Prestone II, Peak or antifreeze containing Alugard 340-2, or their equivalent is recommended for best engine cooling without corrosion. When mixed only to a freeze point of -37°C (-35°F) to -59°C (-50°F). If it loses color or becomes contaminated, drain, flush, and replace with fresh properly mixed solution.

SERVICE

Coolant should be changed at 52,500 miles or three years, whichever occurs first, then every two years or 30,000 miles.

ROUTINE LEVEL CHECK

Do not remove radiator cap for routine coolant level inspections.

The coolant reserve system provides a quick visual method for determining the coolant level without removing the radiator cap. Simply observe, with the engine idling and warmed up to normal operating temperature, that the level of the coolant in the reserve tank (Fig. 15) is between the minimum and maximum marks.

ADDING ADDITIONAL COOLANT

The radiator cap should not be removed. When additional coolant is needed to maintain this level, it should be added to the coolant reserve tank. Use only 50/50 mix of ethylene glycol type antifreeze and water.

SERVICE COOLANT LEVEL

The cooling system is closed and designed to maintain coolant level to the top of the radiator.

When servicing requires a coolant level check in the radiator, the engine must be **off** and **not** under pressure. Drain several ounces of coolant from the radiator drain cock while observing the Coolant Recovery System (CRS) Tank. Coolant level in the CRS tank should drop slightly. Then remove the radiator cap. The radiator should be full to the top. If not, and the coolant level in the CRS tank is at the MIN mark there is an air leak in the CRS system. Check hose or hose connections to the CRS tank, radiator filler neck or the pressure cap seal to the radiator filler neck for leaks.

LOW COOLANT LEVEL AERATION

Low coolant level in a cross flow radiator will equalize in both tanks with engine off. With engine at running operating temperature the high pressure inlet tank runs full and the low pressure outlet tank drops. If this level drops below the top of the transmission oil cooler, air will be sucked into the water pump:

- Transmission oil will become hotter.
- High reading shown on the temperature gauge.
- Air in the coolant can cause loss of flow through the heater.
- Exhaust gas leaks into the coolant also can cause the same problems?

DEAERATION

Air can only be removed from the system by gathering under the pressure cap. On the next heat up it will be pushed past the pressure cap into the CRS tank by thermal expansion of the coolant. It then escapes to the atmosphere in the CRS tank and is replaced with solid coolant on cool down.

COOLING SYSTEM DRAIN, CLEAN FLUSH AND REFILL

Drain, flush, and fill the cooling system at the mileage or time intervals specified in the Mainte-

nance Schedule in this Group. If the solution is dirty or rusty or contains a considerable amount of sediment, clean and flush with a reliable cooling system cleaner. Care should be taken in disposing of the used engine coolant from your vehicle. Check governmental regulations for disposal of used engine coolant.

DRAINING COOLING SYSTEM

To drain cooling system move temperature selector for heater to full heat with engine running (to provide vacuum for actuation). **Without removing radiator pressure cap and with system not under pressure**, Shut engine off and open draincock. The coolant reserve tank (Fig. 14) should empty first, then remove radiator pressure cap. (if not, see Testing Cooling System for leaks). To vent 2.5L engine remove the plug above thermostat housing (Fig. 12).

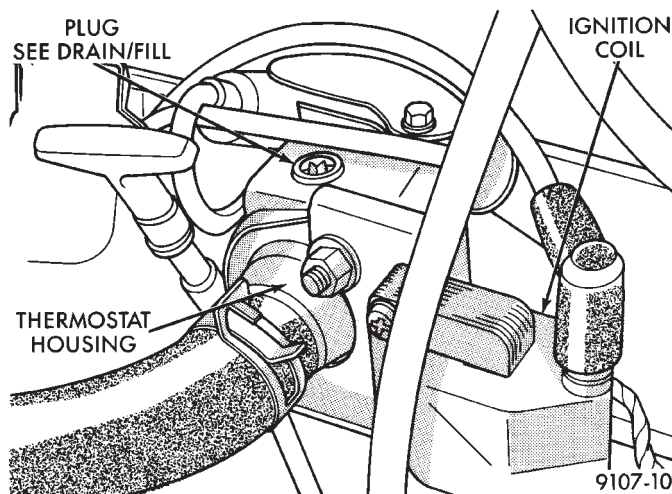

Fig. 12 Thermostat Housing Drain/Fill Plug—2.5L Engine

Removal of a plug or other component is required because these thermostats do not have an air vent and prevents air flow through it. This allows the coolant to drain from the engine block.

CLEANING

Drain cooling system (see: **Draining Cooling System**) and refill with clean water (see **Refilling Cooling System**). Run engine with radiator cap installed until upper radiator hose is hot. Stop engine and drain water from system. If water is dirty, fill, run and drain system again until water runs clear.

REVERSE FLUSHING

Reverse flushing of the cooling system, is the forcing of water through the cooling system, using air pressure in a direction opposite to that of the normal flow of water. This is usually only necessary with very dirty systems with some evidence of partial plugging.

RADIATOR

Drain cooling system and remove radiator hoses from engine. Install suitable flushing gun in radiator lower hose. Fill radiator with clean water and turn on air in short blasts.

CAUTION: Internal radiator pressure must not exceed 138 kPa (20 psi) as damage to radiator may result. Continue this procedure until water runs clear.

ENGINE

Drain radiator (see: **Draining Cooling System**) and remove hoses from radiator. Remove engine thermostat and reinstall thermostat housing. Install suitable flushing gun to thermostat housing hose. Turn on water, and when engine is filled, turn on air, but no higher than 138 kPa (20 psi) in short blasts. Allow engine to fill between blasts of air. Continue this procedure until water runs clean. Reinstall thermostat using a new housing gasket. Fill cooling system (See **Refilling**).

CHEMICAL CLEANING

One type of corrosion encountered with aluminum cylinder heads is aluminum hydroxide deposits. Corrosion products are carried to the radiator and deposited when cooled off. They appear as dark grey when wet and white when dry. This corrosion can be removed with a two part cleaner (oxalic acid and neutralizer) available in auto parts outlets. Follow manufacturers directions for use.

REFILLING

First clean system to remove old glycol, see Cooling System Cleaning.

Fill system, using antifreeze described in Coolant. Fill 50

of capacity with 100

glycol. Then complete filling system with water. The 2.5L engine requires venting by removal of the plug on top of the water box (Fig. 12).

- Install vent plug and tighten to 20 N•m (15 ft. lbs.) for 2.5L Engines.

Continue filling system until full, this provides better heater performance. **Be careful not to spill coolant on drive belts or the generator.**

Fill coolant reserve system to at least the MAX mark with 50/50 solution. It may be necessary to add coolant to the reserve tank after three or four warm up, cool down cycles to maintain coolant level between the MAX and MIN mark. This will allow trapped air to be removed from the system.

TESTING SYSTEM FOR LEAKS

With engine not running, wipe the radiator filler neck sealing seat clean. The radiator should be full.

Attach the Tester Radiator Pressure Tool to the radiator, as shown in (Fig. 13) and apply 104 kPa (15

psi) pressure. If the pressure drops more than 2 psi in 2 minutes inspect all points for external leaks.

All hoses, radiator and heater, should be shaken while at 104 kPa (15 psi) since some leaks occur only while driving due to engine rock, etc.

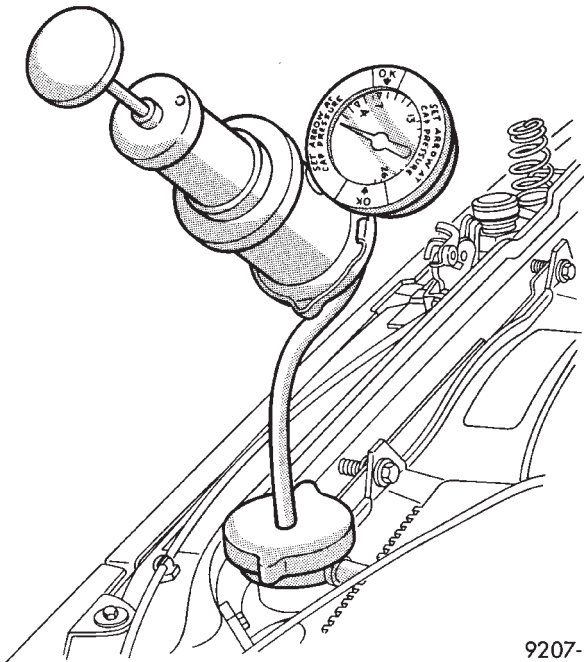

Fig. 13 Pressure Testing Cooling System

If there are no external leaks, after the gauge dial shows a drop in pressure, detach the tester. Start engine and run the engine up to normal operating temperature to open the thermostat and allow the coolant to expand. Reattach the tester. If the needle on the dial fluctuates it indicates a combustion leak, usually a head gasket leak.

WARNING: WITH TOOL IN PLACE, PRESSURE WILL BUILDS UP FAST. EXCESSIVE PRESSURE BUILT UP, BY CONTINUOUS ENGINE OPERATION, MUST BE RELEASED TO A SAFE PRESSURE POINT. NEVER PERMIT PRESSURE TO EXCEED 138 KPA (20 PSI).

If the needle on the dial does not fluctuate, race the engine a few times. If an abnormal amount of coolant or steam emits from the tail pipe, it may indicate a coolant leak caused by a faulty head gasket, cracked engine block, or cracked cylinder head.

There may be internal leaks that can be determined by removing the oil dip-stick. If water globules appear intermixed with the oil it will indicate an internal leak in the engine. If there is an internal leak, the engine must be disassembled for repair.

COOLANT RECOVERY SYSTEM (CRS)

This system works with the radiator pressure cap to use thermal expansion and contraction of the cool-

ant to keep the coolant free of trapped air. Provides a convenient and safe method for checking coolant level and adjusting level at atmospheric pressure without removing the radiator pressure cap. It also provides some reserve coolant to cover minor leaks and evaporation or boiling losses. All vehicles are equipped with this system and take various shapes and forms. (Fig. 14) shows a typical system in the typical location.

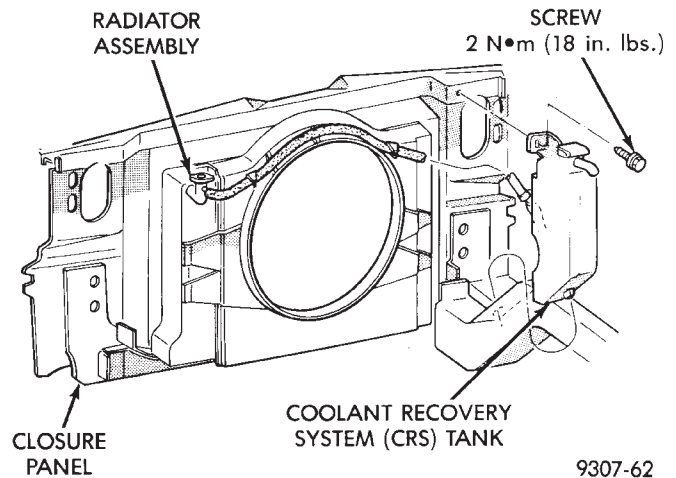

Fig. 14 Typical Coolant Recovery System

See Coolant Level Check Service and Deaeration, and Pressure Cap sections for operation and service. Vehicles equipped with the electric monitor system have a level sensor in the CRS tank, see Group 8, Electrical, for service.

RADIATOR PRESSURE CAP

Radiators are equipped with a pressure cap that releases pressure at some point within a range of 97-124 kPa (14-18 psi).

The system will operate at higher than atmospheric pressure that raises the coolant boiling point allowing increased radiator cooling capacity.

There is also a vent valve in the center of the cap. This valve also opens when coolant is cooling and contracting allowing coolant to return to radiator from coolant reserve system tank by vacuum through connecting hose. **If valve is stuck shut, the radiator hoses will be collapsed on cool down. Clean the vent valve (Fig. 15) to ensure proper sealing when boiling point is reached.**

The gasket in the cap seals the filler neck, so that vacuum can be maintained, allowing coolant to be drawn back into the radiator from the reserve tank.

RADIATOR CAP TO FILLER NECK SEAL PRESSURE RELIEF CHECK

The pressure cap upper gasket (seal) pressure relief can be checked by removing the overflow hose at the radiator filler neck nipple (Fig. 15). Attach the Radiator Pressure Tool to the filler neck nipple and pump

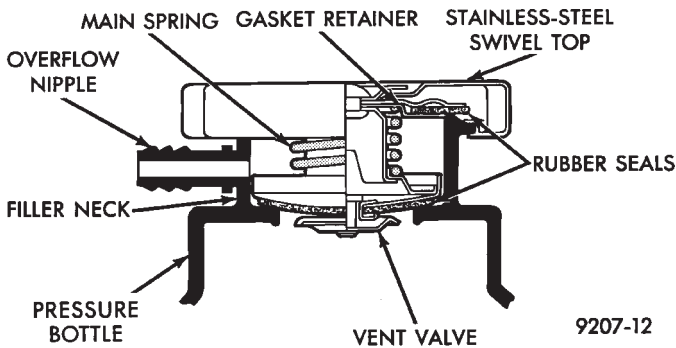

Fig. 15 Radiator Pressure Cap Filler Neck

air into the radiator. Pressure cap upper gasket should relieve at 69-124 kPa (10-18 psi) and hold pressure at 55 kPa (8 psi) minimum.

WARNING: THE WARNING WORDS DO NOT OPEN HOT ON THE RADIATOR PRESSURE CAP IS A SAFETY PRECAUTION. WHEN HOT, PRESSURE BUILDS UP IN COOLING SYSTEM. TO PREVENT SCALDING OR INJURY, THE RADIATOR CAP SHOULD NOT BE REMOVED WHILE THE SYSTEM IS HOT OR UNDER PRESSURE.

There is no need to remove the radiator cap at any time **except** for the following purposes:

- (1) Check and adjust antifreeze freeze point.
- (2) Refill system with new anti-freeze.
- (3) Conducting service procedures.
- (4) Checking for vacuum leaks.

WARNING: IF VEHICLE HAS BEEN RUN RECENTLY, WAIT 15 MINUTES BEFORE REMOVING CAP. THEN PLACE A SHOP TOWEL OVER THE CAP AND WITHOUT PUSHING DOWN ROTATE COUNTER-CLOCKWISE TO THE FIRST STOP. ALLOW FLUIDS TO ESCAPE THROUGH THE OVERFLOW TUBE AND WHEN THE SYSTEM STOPS PUSHING COOLANT AND STEAM INTO THE CRS TANK AND PRESSURE DROPS PUSH DOWN AND REMOVE THE CAP COMPLETELY. SQUEEZING THE RADIATOR INLET HOSE WITH A SHOP TOWEL (TO CHECK PRESSURE) BEFORE AND AFTER TURNING TO THE FIRST STOP IS RECOMMENDED.

PRESSURE TESTING RADIATOR CAP

Dip the pressure cap in water, clean any deposits off the vent valve or its seat and apply cap to end of Radiator Pressure Tool. Working the plunger, bring the pressure to 104 kPa (15 psi) on the gauge. If the pressure cap fails to hold pressure of at least 97 kPa (14 psi) replace cap. See **CAUTION**.

If the pressure cap tests properly while positioned on Radiator Pressure Tool (Fig. 16), but will not hold pressure or vacuum when positioned on the radiator.

Inspect the radiator filler neck and cap top gasket for irregularities that may prevent the cap from sealing properly.

CAUTION: Radiator Pressure Tool is very sensitive to small air leaks that will not cause cooling system problems. A pressure cap that does not have a history of coolant loss should not be replaced just because it leaks slowly when tested with this tool. Add water to the tool. Turn tool upside down and recheck pressure cap to confirm that cap is bad.

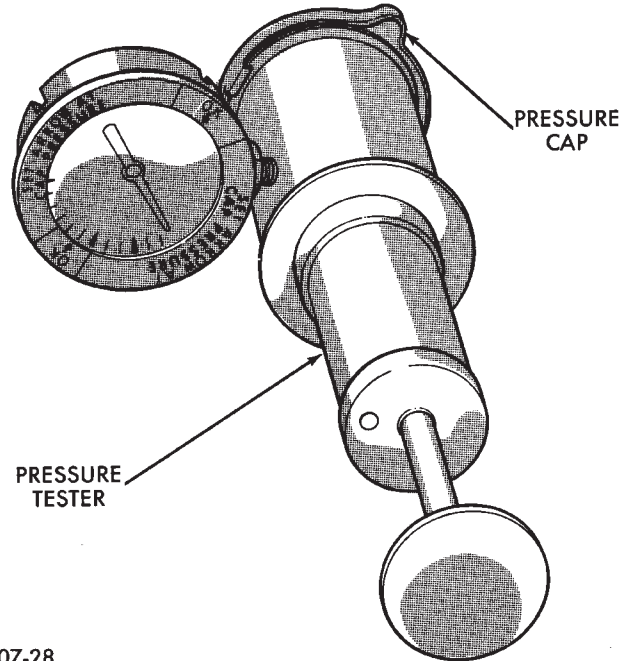

Fig. 16 Pressure Testing Radiator Cap

INSPECTION

Hold the cap in hand, **right side up** (Fig. 15). The vent valve at the bottom of the cap should open. If the rubber gasket has swollen and prevents the valve from opening, replace the cap.

Hold the cleaned cap in hand **upside down**. If any light shows between vent valve and rubber gasket, replace cap. **Do not use a replacement cap that has a spring to hold the vent shut.**

Replacement cap must be of the type designed for coolant reserve system with a completely sealed diaphragm spring, and rubber gasket to seal to filler neck top surface. This design assures coolant return to radiator.

RADIATOR

The radiators are crossflow types (horizontal tubes) with design features that provide greater strength also sufficient heat transfer capabilities to keep the engine satisfactorily cooled (Fig. 1).

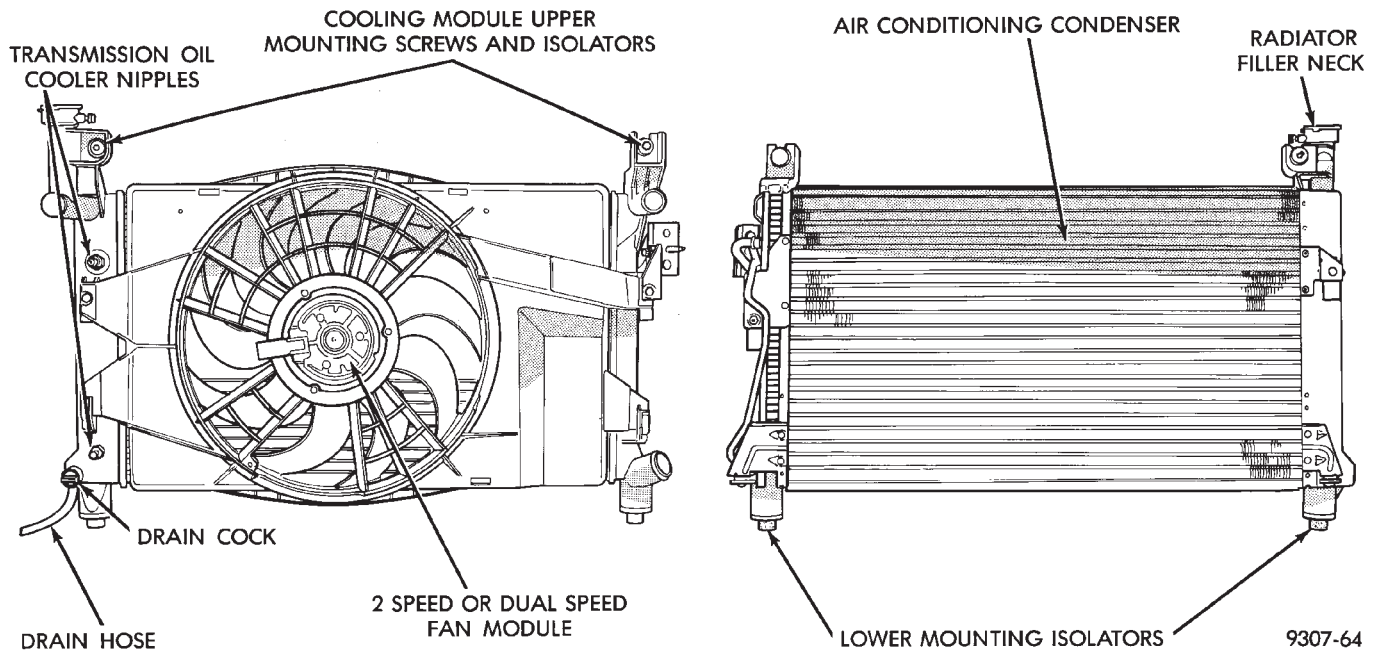

Fig. 1 Cooling Module

CAUTION: Plastic tanks, while stronger than brass are subject to damage by impact, such as wrenches etc., or by excessive torque on hose clamps.

If the plastic tank is damaged, replace the radiator.

RADIATOR DRAINCOCK SERVICE

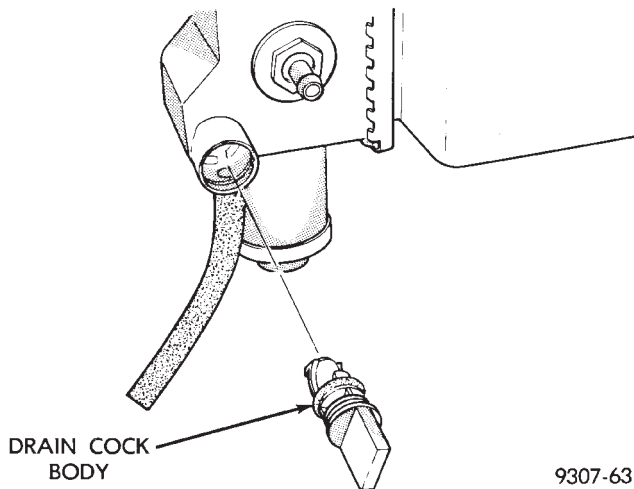

Fig. 2 Draincock Assembled

REMOVAL

CAUTION: Use of pliers on draincock is not recommended. Damage may occur to part. Draincock should not be removed unless leakage observed.

(1) Turn the draincock stem counterclockwise to unscrew the stem. When the stem is unscrewed to

the end of the threads turn back 1/8 turn and, pull the stem (Fig. 2) from the radiator tank.

INSTALLATION

- (1) Push the draincock assembly body into the tank opening until it snaps into place.
- (2) Tighten the draincock stem by turning clockwise until it stops.

RADIATOR COOLANT FLOW CHECK

To determine whether coolant is flowing through the cooling system, use the following procedure:

- (1) If engine is cold, idle engine until normal operating temperature is reached. Then feel the upper radiator hose. If it is hot, coolant is circulating.

WARNING: DO NOT REMOVE RADIATOR PRESSURE CAP WITH THE SYSTEM HOT AND UNDER PRESSURE BECAUSE SERIOUS BURNS FROM COOLANT CAN OCCUR.

- (2) Remove radiator pressure cap when engine is cold. Idle engine until thermostat opens, you should observe coolant flow while looking down the filler neck. Once flow is detected install radiator pressure cap.

REMOVAL

- (1) Disconnect negative battery cable from battery.

WARNING: DO NOT REMOVE THE CYLINDER BLOCK OR THE RADIATOR DRAINCOCK WITH THE SYSTEM HOT AND UNDER PRESSURE BECAUSE SERIOUS BURNS FROM COOLANT CAN OCCUR.

(2) Drain cooling system. Refer to Draining Cooling System of this section.

(3) Remove hose clamps and hoses from the radiator (Fig. 4).

Remove coolant reserve system tank to filler neck tube.

(4) Remove automatic transmission hoses, if equipped.

(5) Remove fan and fan support assembly by disconnecting fan motor electrical connector. Remove upper shroud fasteners, and lift shroud up and out of bottom shroud attachment clips separating shroud from radiator. Fan damage should always be avoided.

(6) Remove front grille. Refer to Group 23 Body for procedure.

(7) Remove A/C condenser fasteners and separate the condenser from the radiator (Fig. 3).

(8) Remove upper radiator mounting screws (Fig. 4). Disconnect the engine block heater wire if equipped.

(9) Radiator can now be lifted free from engine compartment. **Care should be taken not to damage radiator cooling fins or water tubes during removal.**

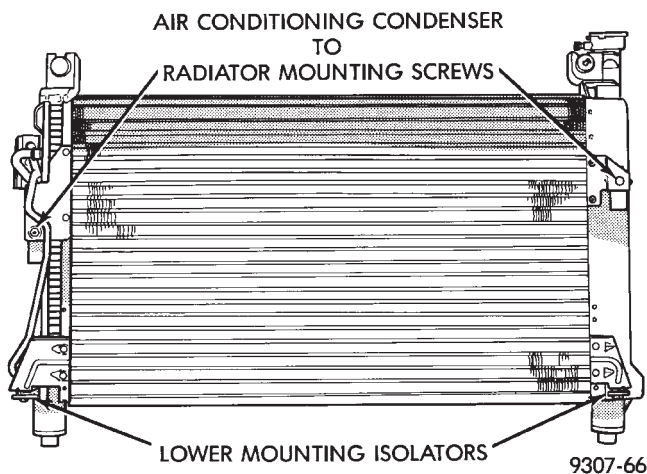

Fig. 3 Air Conditioning Condenser Mounting Screws INSTALLATION

(1) Slide radiator down into position behind radiator support (yoke). Seat the radiator with the rubber isolators into the mount holes provided, with a 10 lbs. force .

(2) Install the upper radiator mounting screws. Tighten radiator mounting bolts to 12 N•m (105 in. lbs.) (Fig. 4).

(3) Install Air Conditioning Condenser onto the radiator (Fig. 3).

(4) Install front grille. Refer to Group 23 Body for procedure.

(5) Connect automatic transmission hoses (if equipped).

(6) Slide fan shroud, fan and motor down into clips on lower radiator tank. Attach upper shroud screws.

(7) Install upper, lower radiator hoses (including coolant reserve hose) (Fig. 4) and fan motor electrical connection. See **Refilling Cooling Systems**.

(6) Connect negative battery cable.

RADIATOR HOSES AND CLAMPS

WARNING: IF VEHICLE HAS BEEN RUN RECENTLY, WAIT 15 MINUTES BEFORE WORKING ON VEHICLE. RELIEVE PRESSURE BY PLACING A SHOP TOWEL OVER THE CAP AND WITHOUT PUSHING DOWN ROTATE IT COUNTER-CLOCKWISE TO THE FIRST STOP. ALLOW FLUIDS TO ESCAPE THROUGH THE OVERFLOW TUBE AND WHEN THE SYSTEM STOPS PUSHING OUT COOLANT AND STEAM AND PRESSURE DROPS.

The hoses are removed by using constant tension clamp pliers to compress hose clamp.

A hardened, cracked, swollen or restricted hose should be replaced. Do not damage radiator inlet and outlet when loosening hoses.

Radiator hoses should be routed without any kinks and indexed as designed. The use of molded hoses is recommended.

Spring type hose clamps are used in all applications. If replacement is necessary replace with the original MOPAR equipment spring type clamp.

FANS

All models use electric motor driven cooling system fan. The fan modules include a motor, shroud and fan. The module is fastened to the radiator by screws (Fig. 5).

All fan motors are two speed. Attempts to reduce high temperature gauge reading by increasing engine speed, at the same vehicle speed, can increase high temperature.

FAN SERVICE

There are no repairs to be made to the fan. If the fan is warped, cracked, or otherwise damaged, it must be replaced with **only** the recommended part for adequate strength, performance and safety.

REMOVAL

Disconnect electric motor lead. Remove fan, motor and shroud as an assembly from radiator support.

CAUTION: Fan is attached with a left hand thread nut.

To remove fan from motor shaft, bench support the motor and motor shaft, while removing the fan retaining nut, so that the shaft and motor will not be damaged by excessive force. **Surface or burr removal may be required to remove fan from motor shaft.** Do not permit the fan blades to touch the bench.

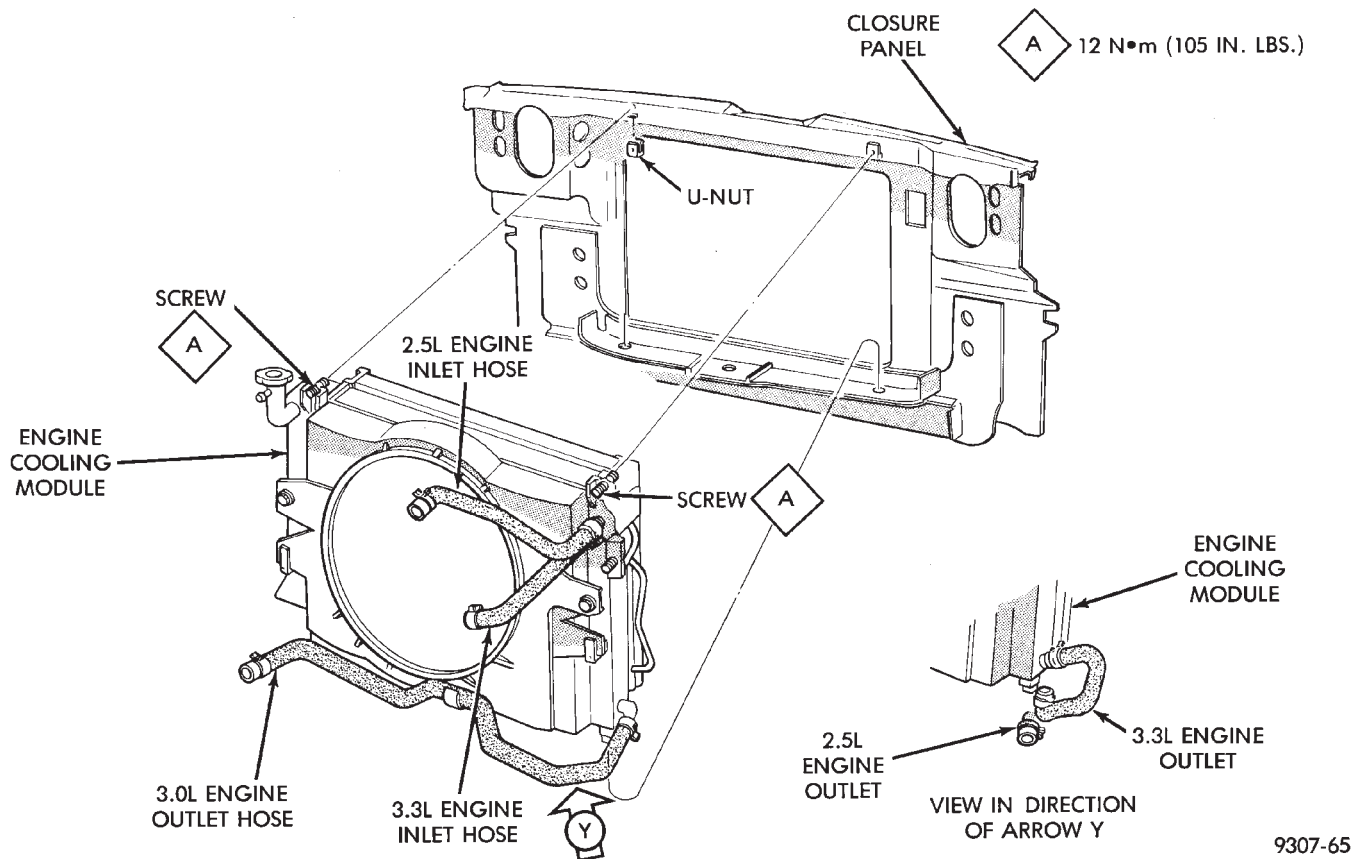

Fig. 4 Engine Cooling Module Mounting

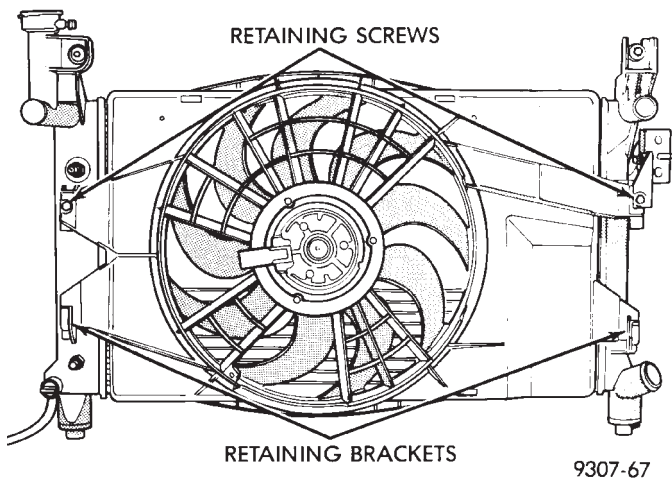

Fig. 5 Fan Module

INSTALLATION

Slide the fan on motor shaft. Support motor and shaft as above, while installing fan retaining nut. Install assembly into pocket on the radiator. Attach support screws. Connect fan motor lead. **For wiring diagrams of fan motor systems see Electrical Group 8.**

RADIATOR FAN CONTROL

Fan control is accomplished two ways. A pressure transducer on the compressor discharge line sends a

signal to the powertrain control module (PCM) which will activate both fans. In addition to this control, the fan is turned on by the temperature of the coolant which is sensed by the coolant temperature sensor which sends the message to the Engine Controller. The Engine Controller turns on the fan through the fan relay. See Wiring Diagrams Manual for circuitry and diagnostics provided.

Switching through the Engine Controller provides fan control for the following conditions;

Air Conditioning NOT Activated

2.5L Engines:

- Low Speed Fan ON 101 °C (215 °F)
- Low Speed Fan OFF 93 °C (199 °F)
- High Speed Fan ON 110 °C (230 °F)
- High Speed Fan OFF 104 °C (219 °F)

3.0/3.3L Engines:

- Low Speed Fan ON 101 °C (215 °F)
- Low Speed Fan OFF 92 °C (198 °F)
- High Speed Fan ON 106 °C (224 °F)
- High Speed Fan OFF 100 °C (212 °F)

The fan will not run during cranking until the engine starts no matter what the coolant temperature is.

TEMPERATURE GAUGE INDICATION

At idle with Air Conditioning off the temperature gauge will rise slowly to about 5/8 gauge travel, the

fan will come on and the gauge will quickly drop to about 1/2 gauge travel this is normal.

ELECTRIC FAN MOTOR

ELECTRIC FAN MOTOR TEST

Refer to Body Diagnostic Manual for procedure

SERVICE

REMOVAL

- (1) Remove the motor fasteners from support (Fig. 13). Remove motor from support.
- (2) Reverse the above procedure for Installation. Torque the fan motor fasteners to 3 N•m (25 in. lbs.).

INSTALLATION

- (1) Install assembly to radiator. Attach retaining clips and torque shroud to radiator fasteners to 5 N•m (45 in. lbs.).
- (2) Connect fan motor lead. **For wiring diagrams of fan motor systems Refer to 8W Wiring Diagrams.**

AUTOMATIC TRANSMISSION OIL COOLERS

Oil cooler is an internal oil to coolant type, mounted in the radiator side tank (Fig. 6).

Rubber oil lines feed the oil cooler and the automatic transmission. Use only approved transmission oil cooler hose. Since these are molded to fit space available, molded hoses are recommended.

TIGHTEN ALL CLAMPS TO 2 N•m (18 in. lbs.)

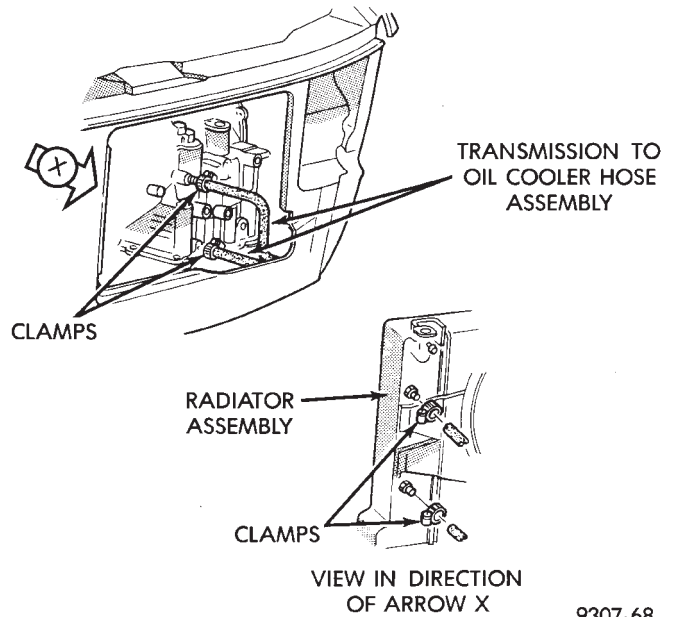

9307-68

Fig. 6 Transmission Oil Cooler



ACCESSORY DRIVE BELTS

INDEX

	page		page
2.5L Engine Belts Remove/Install-Adjust	22	3.3L Engine Accessory Drive Belt Remove/Install	25
3.0L Engine Belts Remove/Install-Adjust	23	General Information	22

GENERAL INFORMATION

PROPER BELT TENSION

Satisfactory performance of the belt driven accessories depends on proper belt tension. Belt tensioning should be performed with the aid of a Burroughs gauge Special Tool C-4162. Because of space limitations in the engine compartment of front wheel drive vehicles, the gauge may be restricted to use after the vehicle has been raised on a hoist and the splash shield has been removed.

Belt tensioning methods are given in order of preference:

- Belt tension gauge method.
- Torque equivalent method.

BELT TENSION GAUGE METHOD

Use belt tensioning Special Tool Kit C-4162 for:

CAUTION: The Burroughs gauge for the Poly-V belt is not to be used on the V-belt. These gauges are not interchangeable.

- For conventional V-belts affix the Burroughs

gauge (Special Tool C-4162) to the belt. Adjust the belt tension for New or Used belt as prescribed in the Belt Tension Chart. For a Poly-V belt affix the Poly-V Burroughs gauge to the belt and then apply specified tension to the belt as prescribed in the Belt Tension Chart

Adjust the belt tension for a **New** or **Used** belt as prescribed in the Belt Tension Chart.

TORQUE EQUIVALENT METHOD

Adjustable accessory brackets provided with a 13mm (1/2 in.) square hole for a torque wrench can use an equivalent torque value for belt adjustment.

Equivalent torque values for adjusting these accessory drive belts are specified on the Belt Tension Chart.

2.5L ENGINE BELTS REMOVE/INSTALL-ADJUST

AIR CONDITIONING COMPRESSOR

(1) Loosen the idler bracket pivot screw A and locking screws B (Fig. 2) to remove and install belt or adjust belt tension.

ACCESSORY DRIVE BELTS DIAGNOSIS

Condition	Possible Cause	Correction
INSUFFICIENT ACCESSORY OUTPUT DUE TO BELT SLIPPAGE	(a) Belt too loose. (b) Belt excessively glazed or worn.	(a) Adjust belt tension. (b) Replace and tighten as specified.
BELT SQUEAL WHEN ACCELERATING ENGINE	(a) Belts too loose. (b) Belts glazed.	(a) Adjust belt tension. (b) Replace belts.
BELT SQUEAK AT IDLE	(a) Belts too loose. (b) Dirt and paint imbedded in belt. (c) Non-uniform belt. (d) Misaligned pulleys. (e) Non-uniform groove or eccentric pulley.	(a) Adjust belt tension. (b) Replace belt. (c) Replace belt. (d) Align accessories. (e) Replace pulley.
BELT ROLLED OVER IN GROOVE OR BELT JUMPS OFF	(a) Broken cord in belt. (b) Belt too loose, or too tight. (c) Misaligned pulleys. (d) Non-uniform groove or eccentric pulley.	(a) Replace belt. (b) Adjust belt tension. (c) Align accessories. (d) Replace pulley.

BELT REPLACEMENT UNDER ANY OR ALL OF THE FOLLOWING CONDITIONS IS REQUIRED, EXCESSIVE WEAR, FRAYED CORDS OR SEVERE GLAZING.

V-RIBBED BELT SYSTEM WITH BACK DRIVE PULLEY MAY DEVELOP MINOR CRACKS ACROSS THE RIBBED SIDE (DUE TO REVERSE BENDING). THESE MINOR CRACKS ARE CONSIDERED NORMAL AND ACCEPTABLE. CRACKS PARALLEL ARE NOT.

DO NOT USE ANY TYPE OF BELT DRESSING OR RESTORER ON V-RIBBED BELTS.

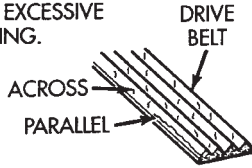

9207-16

Fig. 1 Drive Belt Inspection

(2) Adjust belt tension by applying torque to square hole C on idler bracket. Adjust tension to specification given in Belt Tension Chart.

(3) Tighten in order, first, locking screws B then pivot screw A to 54 N•m (40 ft. lbs.).

POWER STEERING PUMP—S TYPE

(1) From on top of the vehicle loosen locking screw G.

(2) From under the vehicle loosen the pivot screw and pivot nut H.

(3) After installing a new belt adjust belt tension with 1/2 in. breaker bar installed in adjusting bracket. See tension specification in Belt Tension Chart.

- (4) Tighten locking screw G to 54 N•m (40 ft. lbs.).
- (5) Tighten pivot screw H and the pivot nut to 54 N•m (40 ft. lbs.).

GENERATOR BELT

- (1) Loosen generator pivot nut D.
- (2) Loosen T-Bolt locking nut E and adjusting screw F to remove and install Poly V belt or adjust belt tension.
- (3) Tighten pivot nut D TO 54 N•m (40 ft. lbs.).
- (4) Tighten adjusting screw F to adjust belt tension to specification shown in Belt Tension Chart.
- (5) Tighten T-Bolt locking nut E to 54 N•m (40 ft. lbs.).

3.0L ENGINE BELTS REMOVE/INSTALL-ADJUST

AIR CONDITIONING BELT

To remove and install the air conditioning compressor drive belt, first loosen the idler pulley lock nut, then turn the adjusting screw to raise or lower the idler pulley (Figs. 3 and 4).

To adjust the air conditioning drive belt, loosen the idler pulley nut (Fig. 3) and adjust belt tension by tightening adjusting screw (Figs. 3 and 4). Tighten pulley nut to 54 N•m (40 ft. lbs.) after adjustment.

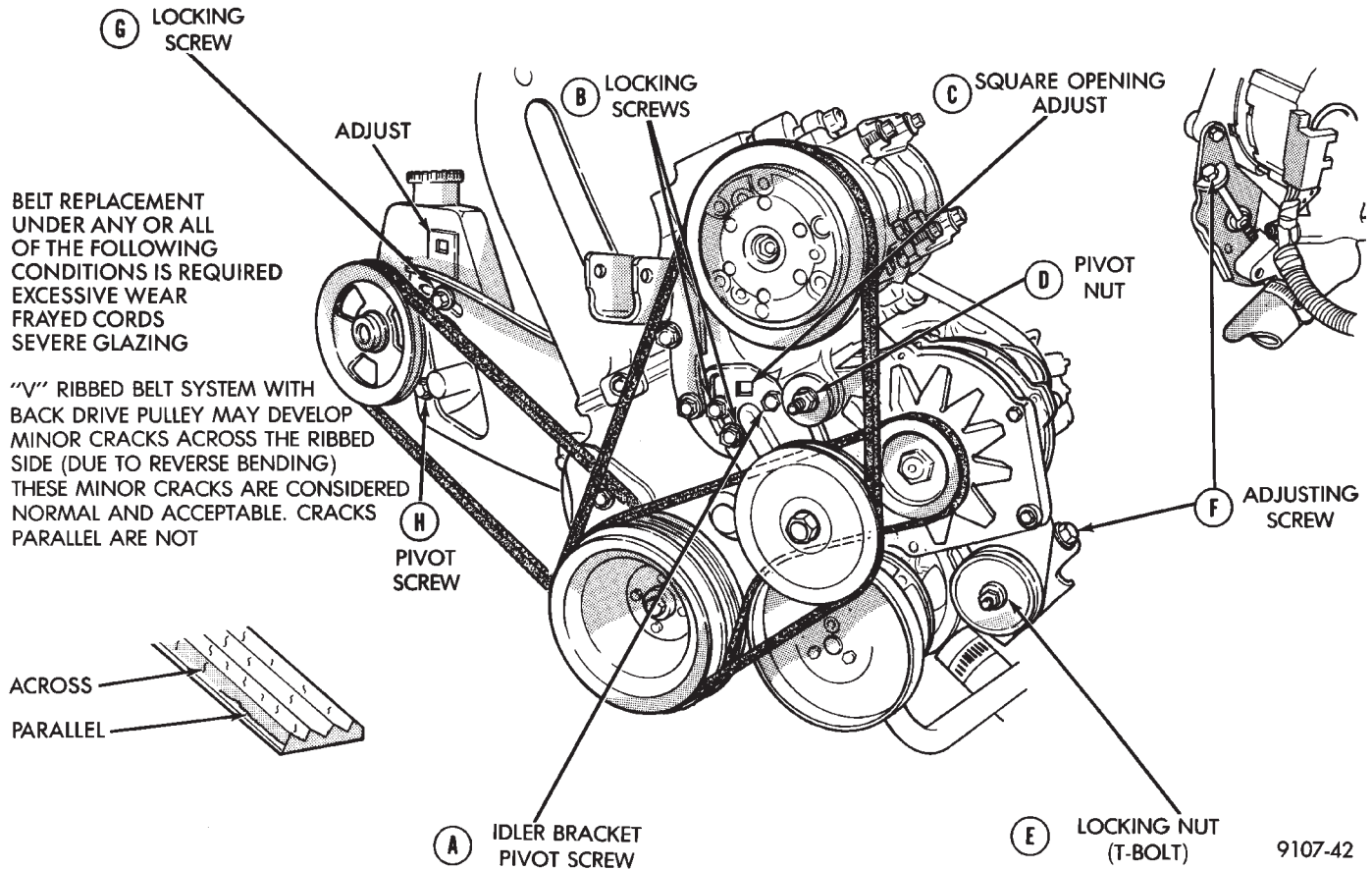

9107-42

Fig. 2 Accessory Drive Belts 2.5L Engine

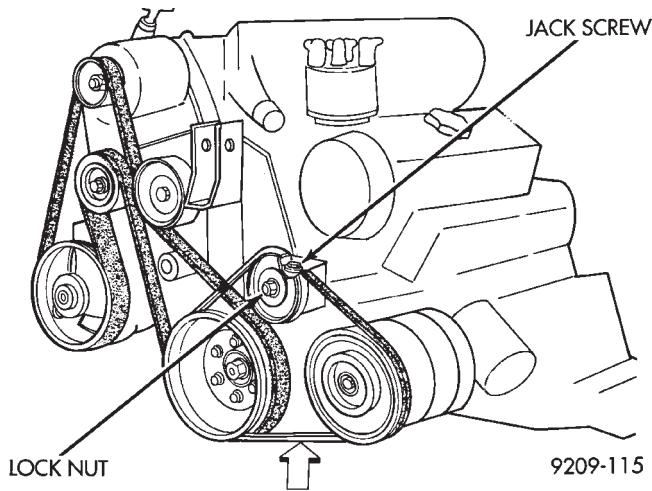

Fig. 3 Accessory Drive Belts—3.0L Engine

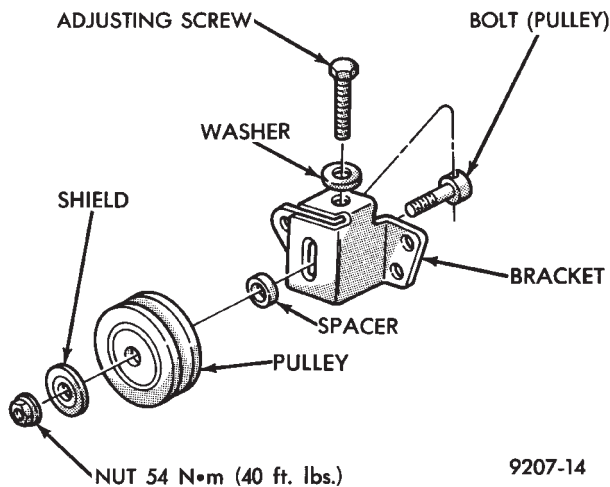

Fig. 4 Air Conditioning Belt Idler

GENERATOR/POWER STEERING PUMP BELT

The Poly-V generator/power steering pump belt is provided with a dynamic tensioner (Fig. 5) to maintain proper belt tension. To remove or install this belt, apply force in a clockwise direction to the tensioner pulley bolt (Fig. 5).

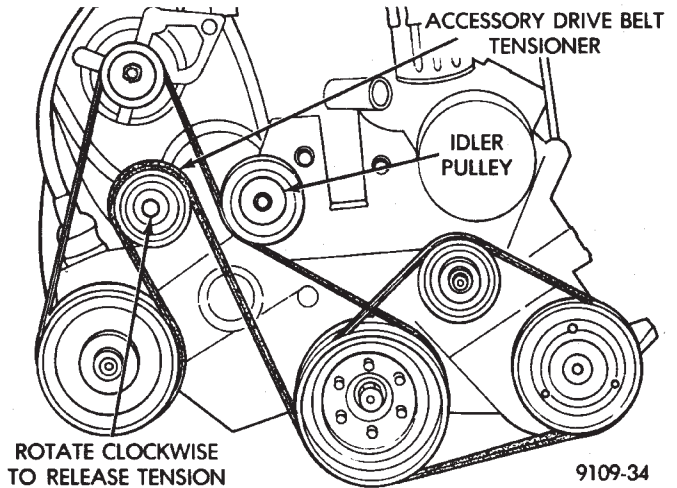

Fig. 5 Release Belt Tensioner

BELT TENSION CHART

ACCESSORY DRIVE BELT		GAUGE	TORQUE
2.5L ENGINE			
AIR CONDITIONING COMPRESSOR	NEW	125 LB.	47 N•M (35 FT. LBS.)
	USED	80 LB.	27 N•M (20 FT. LBS.)
ALTERNATOR/WATER PUMP POLY "V"	NEW	130 LB.	
	USED	80 LB.	
POWER STEERING PUMP	NEW	105 LB.	58 N•M (43 FT. LBS.)
	USED	80 LB.	43 N•M (32 FT. LBS.)
3.0L ENGINE			
AIR CONDITIONING COMPRESSOR	NEW	125 LB.	
	USED	80 LB.	
ALTERNATOR/WATER PUMP/POWER STEERING PUMP	NEW USED		DYNAMIC TENSIONER
3.3L ENGINE			
AIR CONDITIONING COMPRESSOR	NEW USED		DYNAMIC TENSIONER
ALTERNATOR/WATER PUMP/POWER STEERING PUMP			

3.3L ENGINE ACCESSORY DRIVE BELT REMOVE/ INSTALL

GENERATOR, POWER STEERING PUMP, AIR
CONDITIONING COMPRESSOR AND WATER
PUMP DRIVE BELT

The Poly-V Drive belt is provided with a dynamic tensioner (Fig. 6) to maintain proper belt tension. To remove or install this belt.

- (1) Raise vehicle on hoist.
- (2) Remove right front splash shield.
- (3) Release tension by rotating the tensioner clockwise (Fig. 6).
- (4) Reverse above procedure to install.

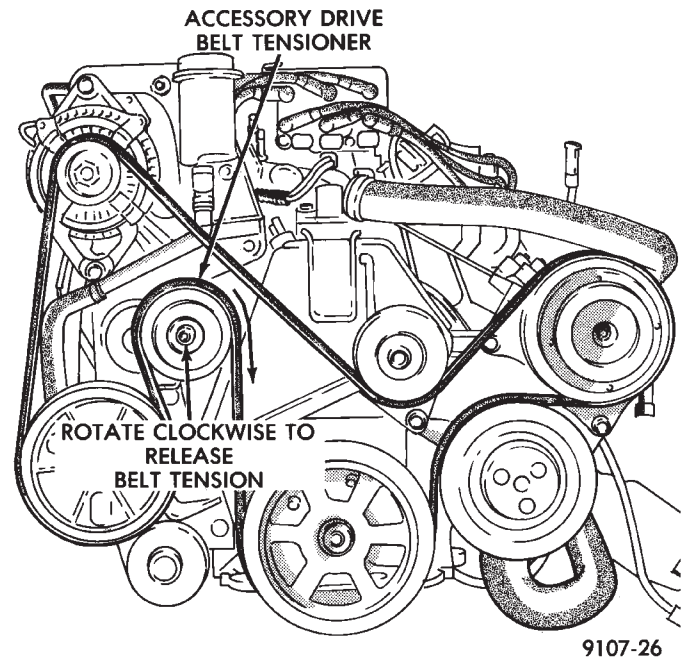

Fig. 6 Accessory Drive Belt—3.3L Engine

ENGINE BLOCK HEATER

DESCRIPTION AND OPERATION

On all models an engine block heater is available as an optional accessory. The heater is operated by ordinary house current (110 Volt A.C.) through a power cord located behind the radiator grille. This provides easier engine starting and faster warm-up when vehicle is operated in areas having extremely low temperatures. The heater is mounted in a core hole (in place of a core hole plug) in the engine block, with the heating element immersed in coolant (Fig. 7).

The power cord must be secured in its retainer clips, and not positioned so it could contact linkages or exhaust manifolds and become damaged.

If unit does not operate, trouble can be in either the power cord or the heater element. Test power cord for continuity with a 110-volt voltmeter or 110-volt test light; test heater element continuity with an ohmmeter or 12-volt test light.

REMOVAL

- (1) Drain coolant from radiator and cylinder block. Refer to Cooling System Drain, Clean, Flush and Refill of this section for procedure.
- (2) Detach power cord plug from heater.
- (3) Loosen screw in center of heater. Remove heater assembly.

INSTALLATION

- (1) Thoroughly clean core hole and heater seat.
- (2) Insert heater assembly with element loop positioned **upward**.
- (3) With heater seated, tighten center screw securely to assure a positive seal.
- (4) Fill cooling system with coolant to the proper level, vent air, and inspect for leaks. Pressurize system with Radiator Pressure Tool before looking for leaks.

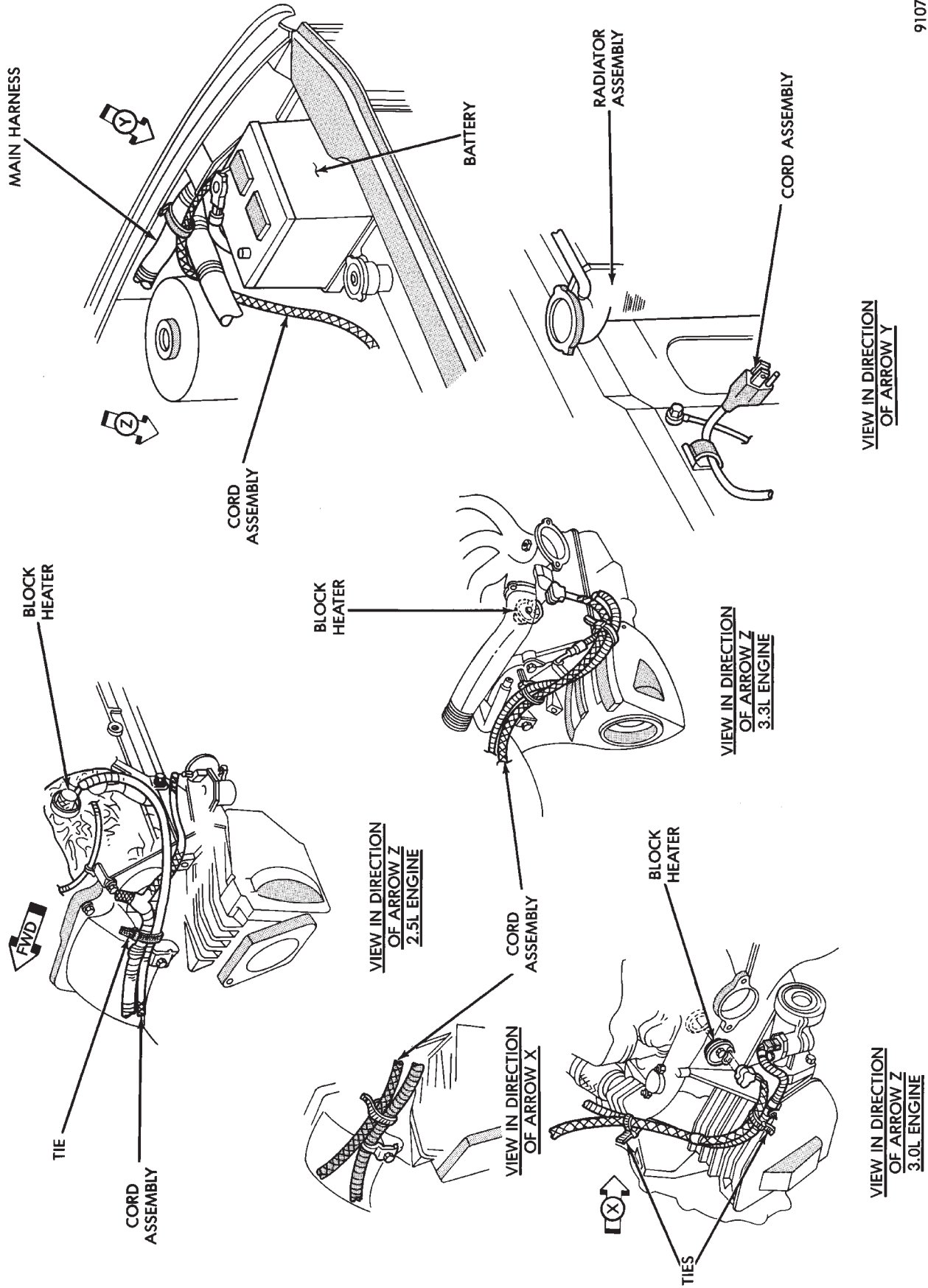

9107-45

Fig. 7 2.5L, 3.0L and 3.3L Engines Block Heater Assembly

SPECIFICATIONS
TORQUE

	2.5L	3.0L	3.3L
THERMOSTAT HOUSING BOLT NUT (ALSO RETAINS DIP STICK TUBE) 2.5L	28 N*m (250 IN. LBS.)	12 N*m (113 IN. LBS.)	28 N*m (250 IN. LBS.)
WATER PUMP MOUNTING BOLTS	UPPER (3) 28 N*m (250 IN. LBS.) LOWER (1) 72 N*m (40 FT. LBS.)	ALL 27 N*m (240 IN. LBS.)	11.9 N*m (105 IN. LBS.)
WATER PUMP COVER TO HOUSING BOLTS	12 N*m (105 IN. LBS.)		
WATER PUMP PULLEY SCREWS	28 N*m (250 IN. LBS.)		28 N*m (250 IN. LBS.)
WATER INLET PIPE (BRACKET TO CYLINDER HEAD SCREWS		11 N*m (94 IN. LBS.)	
TRANSMISSION OIL COOLER HOSE CLAMP	2.0 N*m (18 IN. LBS.)		
FAN SUPPORT BOLTS	11.9 N*m (105 IN. LBS.)	11.9 N*m (105 IN. LBS.)	11.9 N*m (105 IN. LBS.)
FAN MOTOR MOUNTING NUT	6.8 N*m (60 IN. LBS.)	6.8 N*m (60 IN. LBS.)	6.8 N*m (60 IN. LBS.)
UPPER RADIATOR MOUNTING BRACKET NUT	11.9 N*m (105 IN. LBS.)	11.9 N*m (105 IN. LBS.)	11.9 N*m (105 IN. LBS.)

9307-71

COOLING SYSTEM CAPACITY

ENGINE	2.5L	3.0L	3.3L
(COOLANT) *CAPACITY			
LITERS	9.0	9.5	9.5
U.S. QTS.	9.5	10.0	10.0

*CAPACITY, Includes Heater and Coolant Recovery System

9107-50

